

L. B. KENNEDY.
Brick-Machine.

No. 206,247.

Patented July 23, 1878.

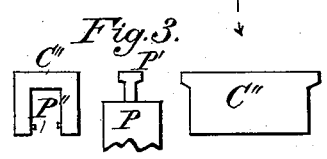
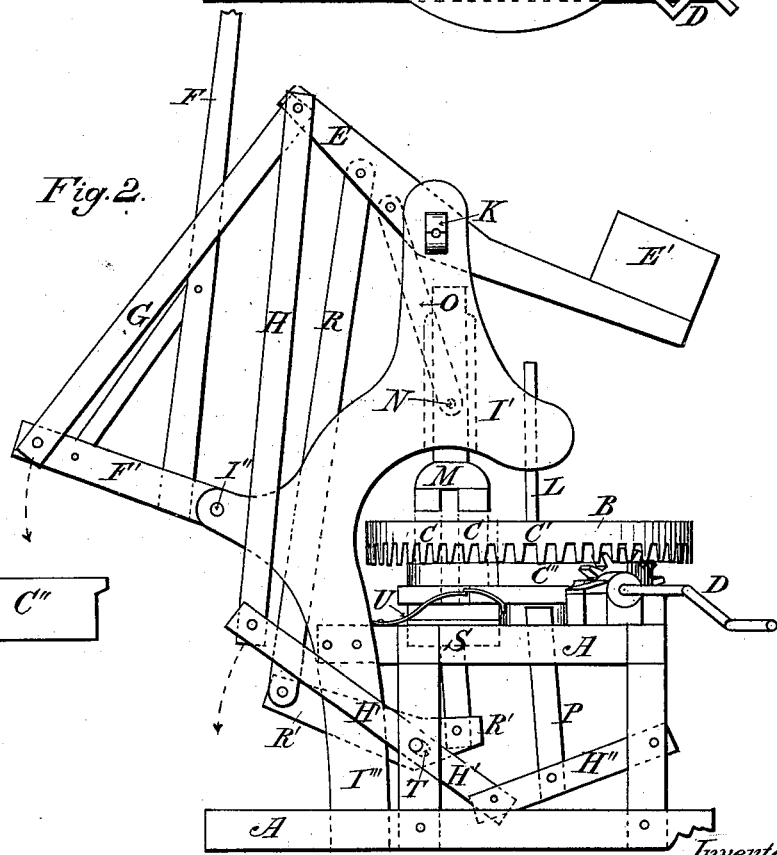
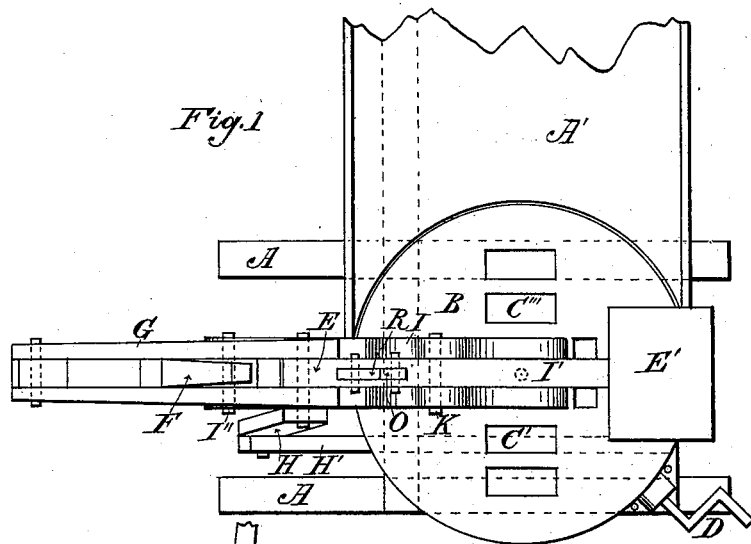

Attest:
F. W. Schmidt
Essex

Inventor:
L. B. Kennedy

UNITED STATES PATENT OFFICE.

LEWIS B. KENNEDY, OF WAXAHATCHE, TEXAS.

IMPROVEMENT IN BRICK-MACHINES.

Specification forming part of Letters Patent No. **206,247**, dated July 23, 1878; application filed April 13, 1878.

To all whom it may concern:

Be it known that I, LEWIS B. KENNEDY, of Waxahatchie, Ellis county, Texas, have invented a new and useful Improvement in Brick-Machines. This is made substantially as hereinafter set forth, referring to the accompanying drawings, in which—

Figure 1 is a top or plan view of the machine; Fig. 2, an elevation of same, and Fig. 3 details of parts.

This invention is an improved machine for molding moist, not wet, clay into brick, ready for hacking up, by pressure operated by hand-levers, and having the several improved features set forth and claimed hereinafter.

The machine has a stationary frame, A, on which the other parts are suitably mounted. The clay for the brick is used with about the usual degree of moisture when dug from the bank, so that it may be compacted, by powerful pressure of a combination of levers and rams, into brick sufficiently solid for hacking up or putting into the kiln at once, to save expensive handlings and risk of loss by rain, &c.

The clay is placed on table A'. From this it is fed by an operator into molds C in table B. When these are filled the table B, which is mounted on a vertical pivot, L, so as to revolve horizontally, is turned by hand-crank D, operating a bevel-wheel acting on teeth on the bottom of the table, so as to bring molds C under the ram-plungers M. The table B has four pairs of these molds arranged in it, so that an operator may be filling two while two are being pressed between rams M and S, and while the brick are being taken out of two others, in continuous series, thus saving time and labor.

The molds C have movable bottoms C'', borne by the table, and when the filled molds are turned under plungers M they are over the bottom part, S. The lever F is then moved backward, turning on pivot I'' of upright frame I, and moving down arm F'. This draws down bars G and lever E. The lever E has pivoted to it a thrust-bar, O. This is pivoted to the guide N of the plungers M, which works in bearings in frame I, so as to

force the plungers down onto the clay in the molds to compress it into bricks. The lever E bears another thrust-bar, R, acting on a lever, R', pivoted at T. This lever R' bears a thrust-bar bearing the platform S, so as to force that up when the plungers descend. The part S acts against the mold-bottoms C'' so as to push them up against the clay from below as it is being pressed, giving double pressure and a solid bottom to the molds.

As the lever F is drawn back it increases in power and effect upon the brick as the arm F' reaches a dead-center with its pivots, by which an enormous pressure is exerted on the brick in the molds, making them very hard and solid.

When the compression is complete lever F is returned to the position shown, which is assisted by counter-weight E' on the end of lever E. This frees the plungers M from the molds, and permits the table B to be turned again by crank D, so as to bring the molds with brick into position C' over the upper ends of plungers P.

The lever E bears bar H, operating-lever H', pivoted at T, with a pivot-slot for sliding, and moving-lever H'', which bears the plunger-bar P, so arranged that when the lever F is operated to compress brick under plunger M the bars P push the brick up out of molds C'. The plungers P push the mold-bottoms C'' up and discharge the brick on top of the table B, so they may be taken off by an attendant for hacking up or putting into the kiln.

The plungers P bear T-headed parts P', which enter peculiar slots in the bottoms of parts C'', and when they descend engage with projections P'' in their sides, so as to draw down C'' into the molds again.

The table B bears a lower rim, B', with four notches around it, into which a spring-catch, U, falls, to hold it in right position for the plungers to enter the molds.

The lever E has a sliding block for its pivot in frame I. This is adjusted up and down by wedges K in frame I, to regulate pressure of plungers M and size of brick.

I claim—

1. In a brick-machine, the combination of levers F E, bars G O N, and plunger M, substantially as set forth.

2. The brick-machine with hand-lever F, plunger M, and adjusting-keys K, substantially as set forth.

3. A brick-machine having revolving table B, operating-lever F, plunger M, and the counter-balance E', substantially as set forth.

4. In a brick-machine, the combination of hand-lever F and operating plungers or parts M

S with the revolving table, having molds C, substantially as set forth.

5. A brick-machine having a movable mold-bottom C'', with slots and catches P'', and plunger-bar P, with head P', arranged to engage with them, substantially as set forth.

LEWIS B. KENNEDY.

Witnesses:

Z. P. DEDERICK,

THOS. W. RANDOLPH.