

J. M. SEARLE & G. G. PALMER.
 Rotary Exhaust-Cylinders and Balanced Slide-Valve
 for Steam-Engines.

No. 206,268.

Patented July 23, 1878.

Fig. 1.

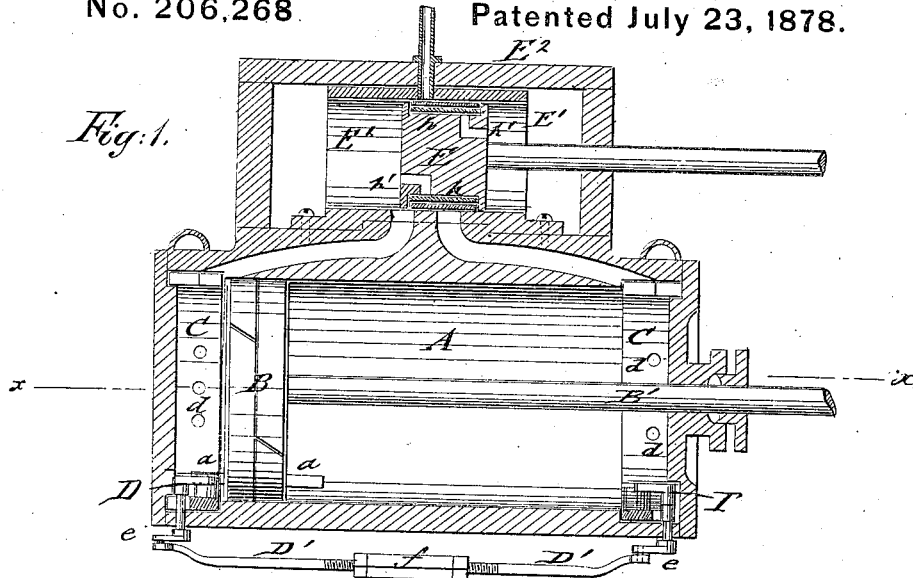

Fig. 2.

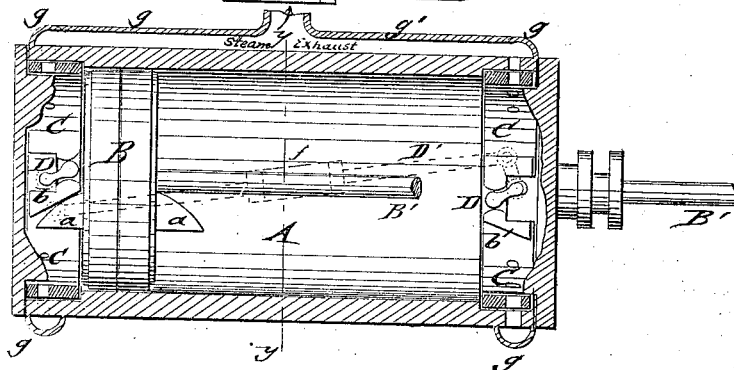
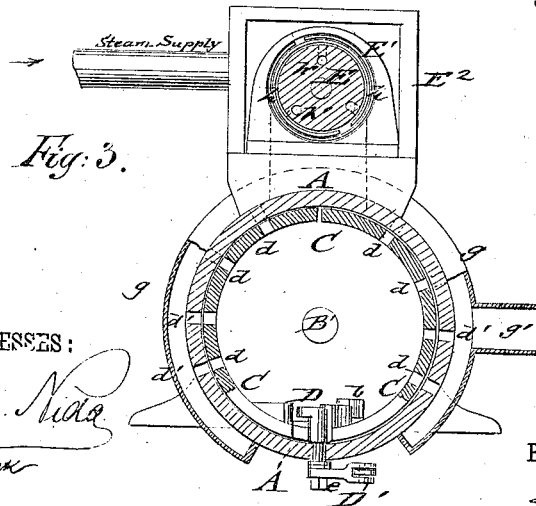

Fig. 3.



WITNESSES:

Chas. Niles
C. Sedgwick

INVENTOR:

J. M. Searle
G. G. Palmer

BY

Munroe

ATTORNEYS.

UNITED STATES PATENT OFFICE.

JOSEPH M. SEARLE AND GIDEON G. PALMER, OF STANHOPE, N. J.

IMPROVEMENT IN ROTARY EXHAUST-CYLINDERS AND BALANCED SLIDE-VALVES FOR STEAM-ENGINES.

Specification forming part of Letters Patent No. 206,268, dated July 23, 1878; application filed June 6, 1878.

To all whom it may concern:

Be it known that we, JOSEPH M. SEARLE and GIDEON G. PALMER, of Stanhope, in the county of Sussex and State of New Jersey, have invented a new and Improved Rotary Exhaust-Cylinder and Balanced Slide-Valve for Steam-Engines, of which the following is a specification:

In the accompanying drawing, Figure 1 represents a vertical longitudinal section of our improved rotary exhaust-cylinder for steam-engines; Fig. 2, a horizontal section on line *x x*, Fig. 1; and Fig. 3, a vertical transverse section of the same on line *y y*, Fig. 2.

Similar letters of reference indicate corresponding parts.

The object of our invention is to furnish an improved rotary exhaust-cylinder for steam-engines, in which a positive exhaust is obtained at any or all points of the cut-off, as the exhaust-ports remain open during the entire return stroke of the piston.

After the steam is exhausted the exhaust-ports stay open until the piston makes the entire length of its stroke, so as to get the full benefit of the expansion, and do away entirely with back pressure.

The arrangement of the rotary exhaust in the cylinder simplifies the construction of the slide-valve, and dispenses, when a balanced valve is used, entirely with valve-facings, so as to reduce, in conjunction with the improved exhaust, the consumption of fuel and the expense for repairs in a considerable degree.

The invention consists of rotary exhaust-rings at both ends of the steam-cylinder, which are set by fixed lugs of the piston engaging beveled cheeks of the rings when arriving at the end of each stroke. The rings are connected by interior cranks and by an outer crank-rod, so that when the exhaust-ports at one end are closed by the piston the exhaust-ports at the opposite end are simultaneously opened.

The exhaust-rings are perforated, and arranged to open or close the exhaust-ports of the cylinder.

The steam is supplied by a top chest and ports in connection with a balanced and steam-packed piston-valve.

Referring to the drawing, A represents a

steam-cylinder; B, the piston of the same; and B' the piston-rod, which is guided in the usual manner by a cross-head.

The piston B is provided at opposite sides, near the circumference, with projecting lugs *a*, having curved or beveled faces, that engage, when the piston arrives at either end of its stroke, the inclined or beveled cheeks *b* of rotary exhaust-rings C, which are guided in annular end grooves of the cylinder and of the cylinder-heads.

The exhaust-rings C are made of two sections, and provided with radial holes *d*, that register with radial ports *d'* of the cylinder, so as to exhaust the steam. The holes *d* may also be set intermediately between the exhaust-ports *d'*, so as to interrupt their connection and shut off the exit of steam.

The opening or closing of the exhaust-ports is accomplished by the action of the lugs of the piston B on the contact-cheeks of the exhaust-rings. The exhaust-rings C are also recessed at their lowermost parts, near the cheeks *b*, and acted upon by short cranks D, whose shafts extend through the cylinder, and are connected at the outside by short crank-arms *e* and by a crank-rod, D'.

The connecting crank-rod D' is made of two parts, which are secured by their threaded ends and screw-nuts adjustably to a center sleeve, *f*, so as to admit the perfect adjustment of the cranks and the exact setting of the exhaust-rings to the ports of the cylinder.

The action of the piston on one of the rings at the end of the stroke closes the exhaust-ports at that end of the cylinder, but sets at the same time the exhaust-ring at the opposite end so that its holes register with the opposite exhaust-ports.

The steam escapes from the ports through annular hollow channels or ducts *g* and through longitudinal connecting-channels *g'* to the exhaust-opening at one side of the cylinder.

The steam is supplied at the end of each stroke by the action of a balanced piston-valve, B, that slides in a fixed cylindrical sleeve, B', of the valve-chest B² at the top of the cylinder A.

The piston-valve admits steam to the steam-entrance ports, and is made of an ordinary piston, that has two wide expansion-rings, *h*, fit-

ted around it. The rings are cut at one point to allow the steam when it enters the chest to pass into small angular holes *h'* of the piston-heads, and then under the rings, so as to expand them, fit them tightly to the sleeve, and keep them from leaking.

The construction of the cylinder with rotary exhaust-rings admits the use of a very simple construction of supply-valve, as the exhaust is not made through the same. The balanced piston-valve has the advantage, however, of requiring no collars or sections of flanged rings to break joints, as it does not matter whether steam passes from one side of the valve to the other.

The expanding rings have to be of the length of the valve-piston, with the cut of the outer ring at the top, and of the inner ring at the bottom, so that the joints do not come in contact with the ports and admit steam from its face instead of from the edge.

The steam may be cut off at any point of the stroke, and then carried through the whole length of the cylinder before it is exhausted, so as to get the full benefit of the expansion and dispensing with back pressure.

As soon as the piston arrives at the end of its stroke the opposite exhaust-ports are opened, and the steam exhausts, during the return of the piston, through the entire length of the cylinder, when the exhaust-ports at this end are closed, and those at the other opened, and so on, the engine working thus advantageously, and at a considerable saving in fuel and repairs.

Having thus described our invention, what

we claim as new, and desire to secure by Letters Patent, is—

1. The combination of a steam-cylinder having rotary exhaust-rings and connecting exhaust-ports at both ends with a piston having projecting lugs, and with ring-connecting crank-mechanism, that closes the exhaust-ports at one end and simultaneously opens the exhaust-ports at the opposite end of the cylinder, substantially as specified.

2. The combination of the cylinder A, having radial exhaust-ports at both ends, inner rotary exhaust-rings C, having radial holes, crank-recesses, and cheeks, piston B, having projecting lugs at opposite sides, and ring-connecting cranks D and exterior crank-rod D', substantially as and for the purpose described.

3. The combination of a steam-cylinder having exhaust-ports and rotary exhaust-rings at the ends and steam-supply ports, with a balanced piston-valve, guided in a fixed sleeve of the valve-chest, substantially as set forth.

4. The combination, with a steam-cylinder having exhaust-ports and rotary exhaust-rings and steam-supply ports, of a balanced steam-valve, guided in a sleeve of the valve-chest, and having split packing-rings and steam-openings below the rings, substantially as described.

JOSEPH MINER SEARLE.
GIDEON G. PALMER.

Witnesses:

JOHN D. LAWRENCE,
A. J. DRAKE,
J. D. LAWRENCE,
B. S. CLARK.