

H. C. GROS.
Boot and Shoe Sewing-Machine.
No. 206,317. Patented July 23, 1878.

Fig 1.

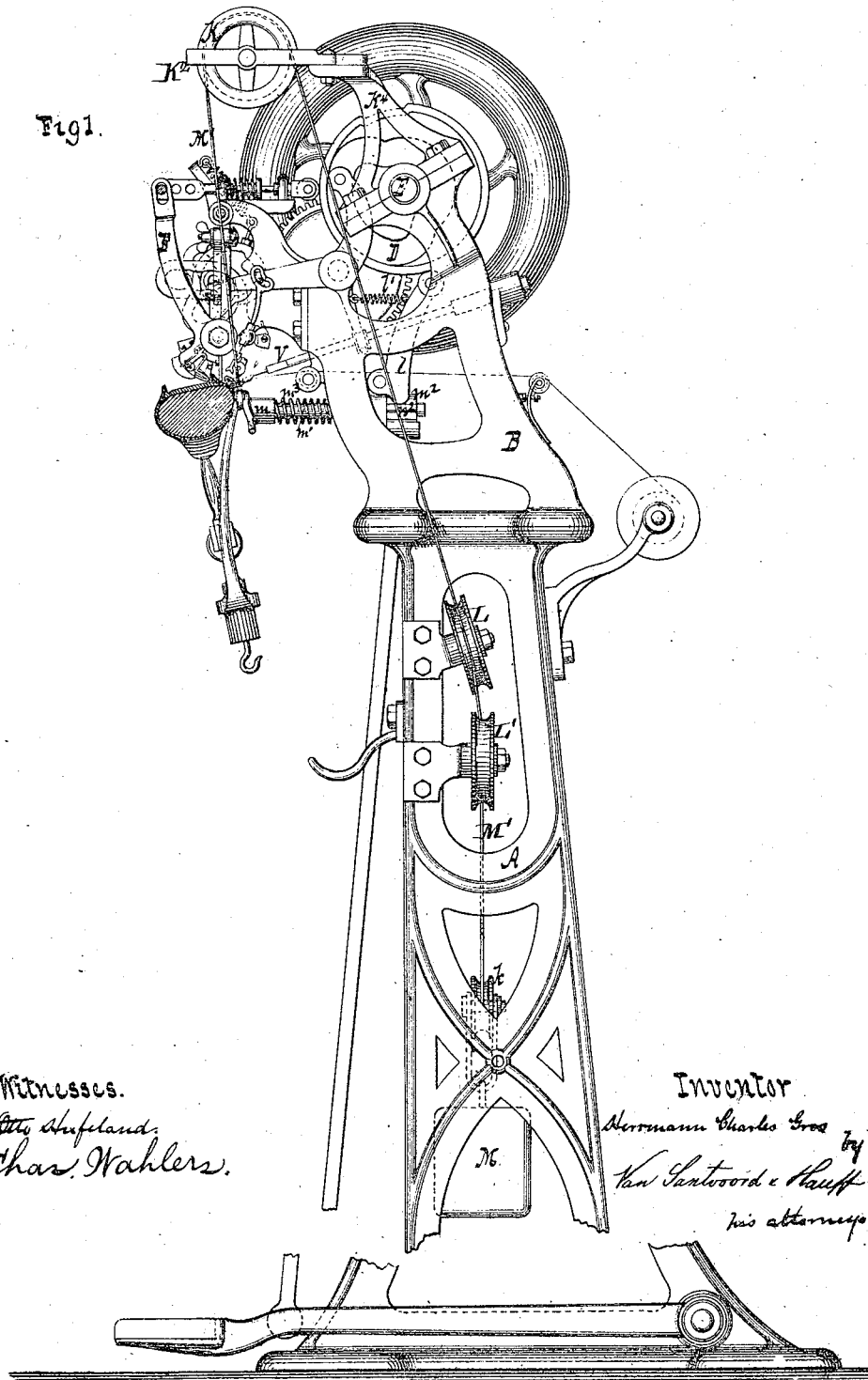

Witnesses.
Atty. Shufeland.
Chas. Wahlers.

Inventor
Herrmann Charles Gros by
Sam. Santwood & Hauff
his attorneys

H. C. GROS.
Boot and Shoe Sewing-Machine.
No. 206,317. Patented July 23, 1878.

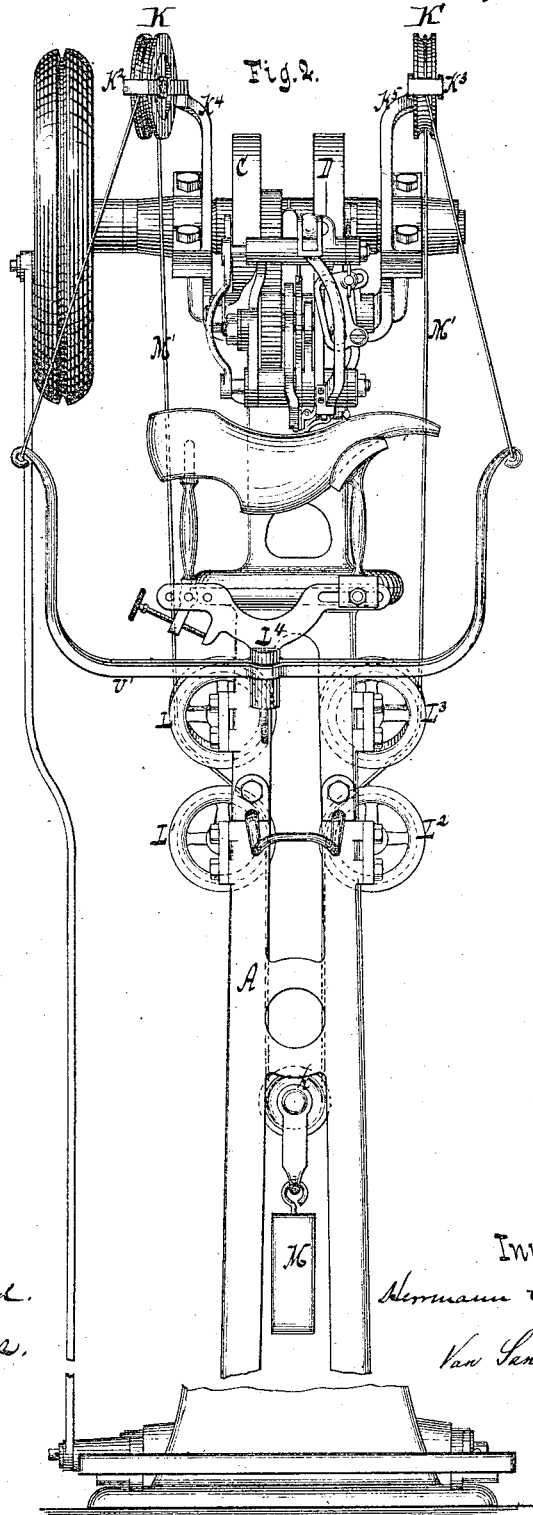

Witnesses
Otto Stiefeland.
Chas. Wahlers.

Inventor
Hermann Charles Gros
by
Van Senterwood & Hauff
his attorneys

H. C. GROS.
Boot and Shoe Sewing-Machine.
No. 206,317. Patented July 23, 1878.

Fig. 3.

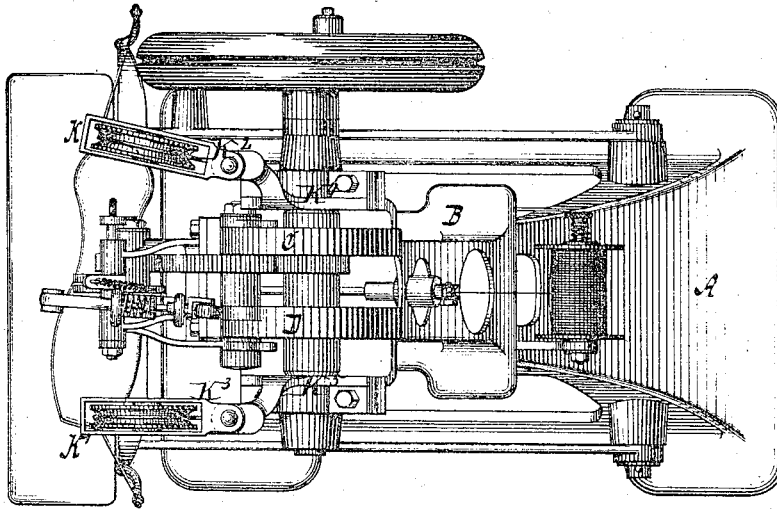
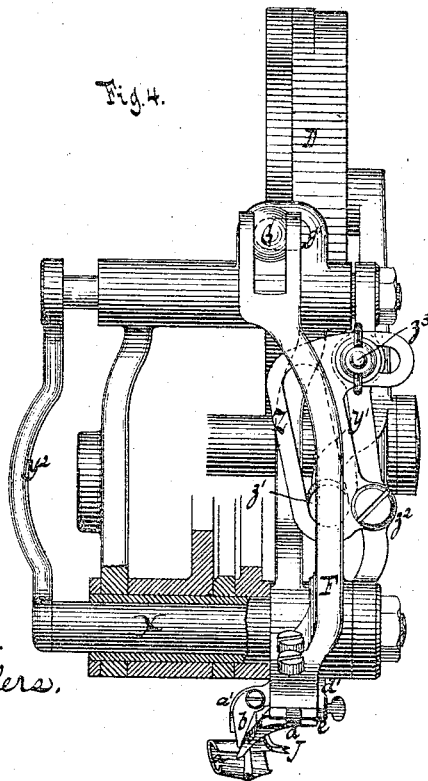
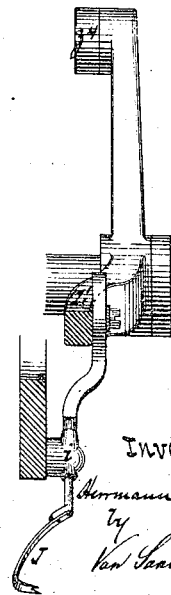

Fig. 4.



Witnesses
Eto Hufeland.
Char. Wahlers.

Fig. 5.



Inventor.

Hermann Charles Gros
by
Van Schootwood & Clauff
his attys.

H. C. GROS.
Boot and Shoe Sewing-Machine.
No. 206,317. Patented July 23, 1878.

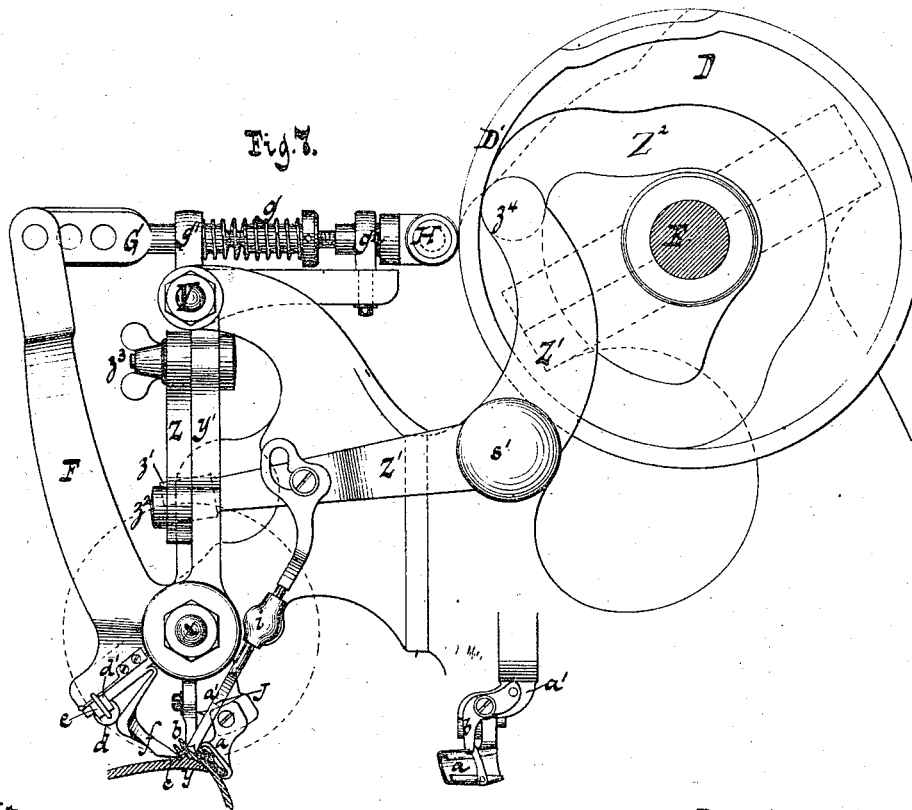
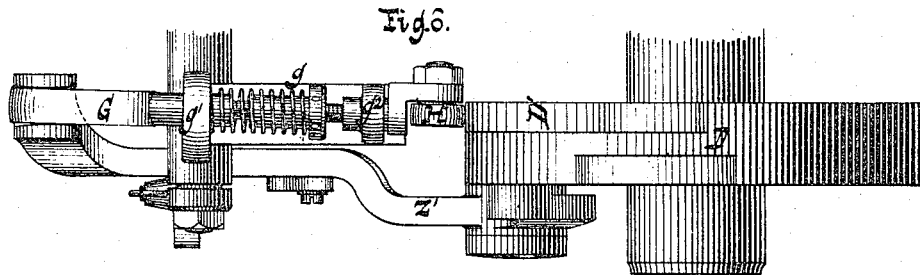

Witnesses.
Otto Aufeland
Chas. Wahlers.

Inventor.
Hermann Charles Gros
7
Van Santvoord & Hauff

vis attyo

H. C. GROS.
Boot and Shoe Sewing-Machine.
No. 206,317. Patented July 23, 1878.

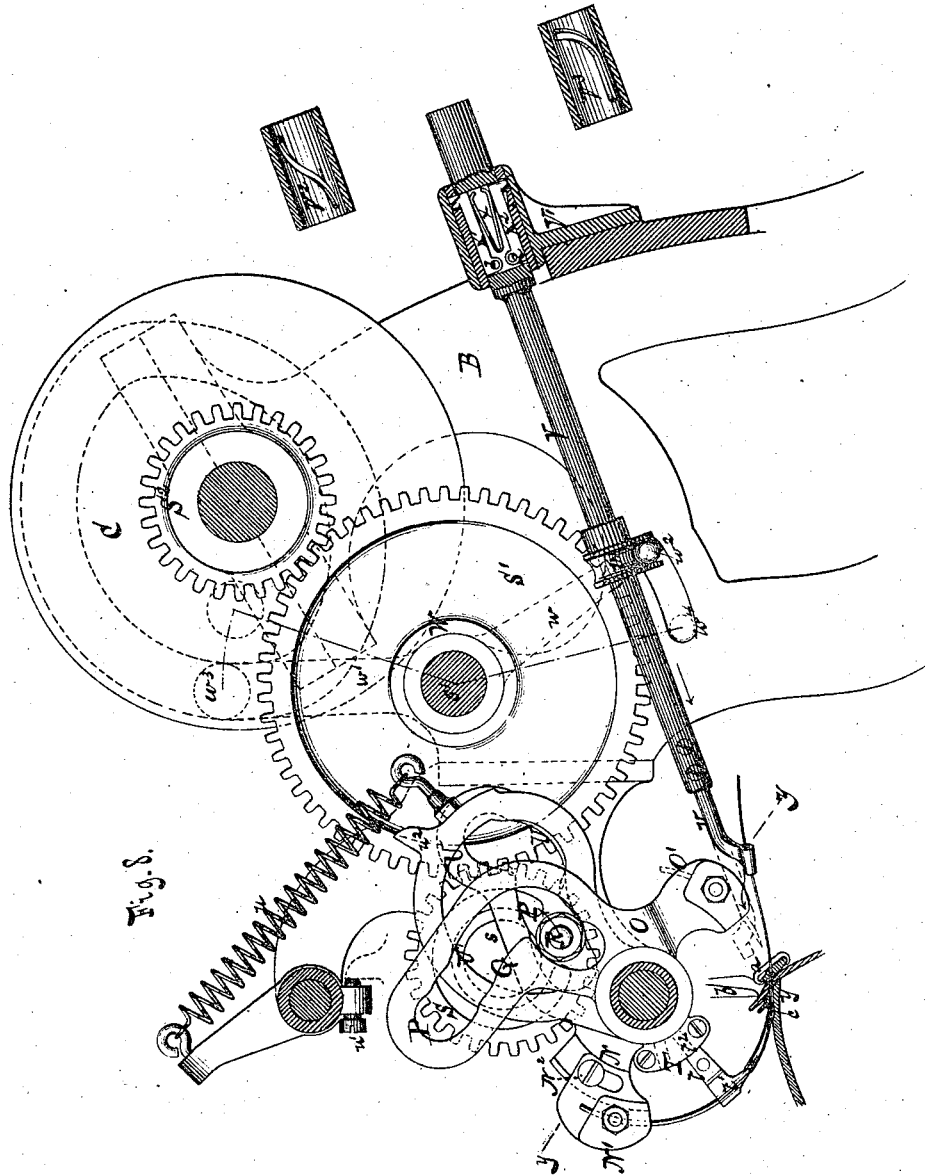

Witnesses.
Otto Kufeland.
Chas. Wählers.

Inventor.
Herrmann Charles Gros
Van Santvoord & Hauff
his attorneys

H. C. GROS.
Boot and Shoe Sewing-Machine.
No. 206,317. Patented July 23, 1878.

Fig. 9.

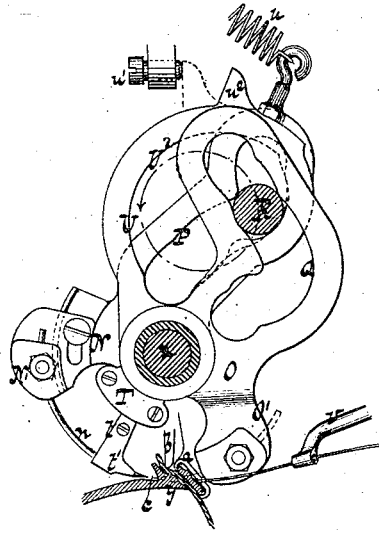

Fig. 10.

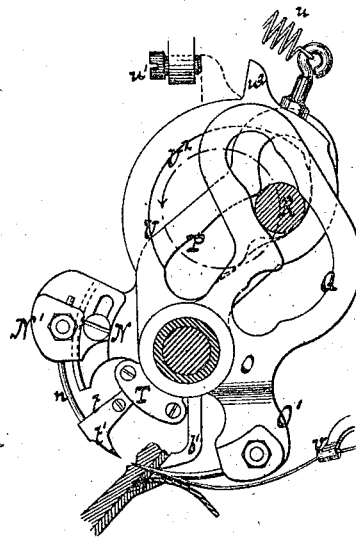

Fig. 11.

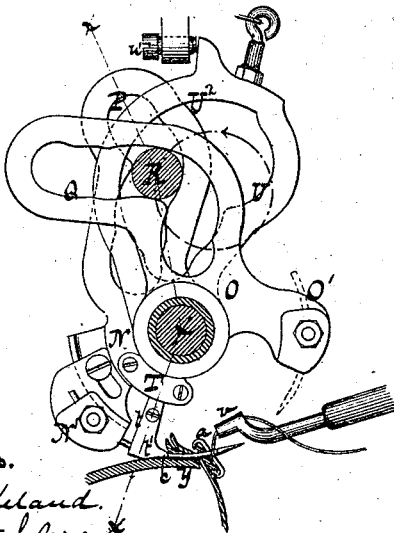
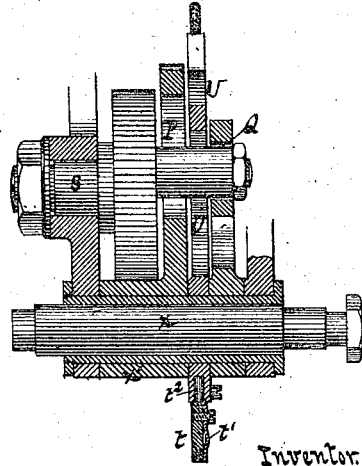

Fig. 12.



Witnesses.
Otto Hufeland.
Char. Kahlers.

Inventor
Hermann Charles Gros
by
Van Fleetwood & Hauff

his attorneys.

H. C. GROS.
Boot and Shoe Sewing-Machine.
No. 206,317. Patented July 23, 1878.

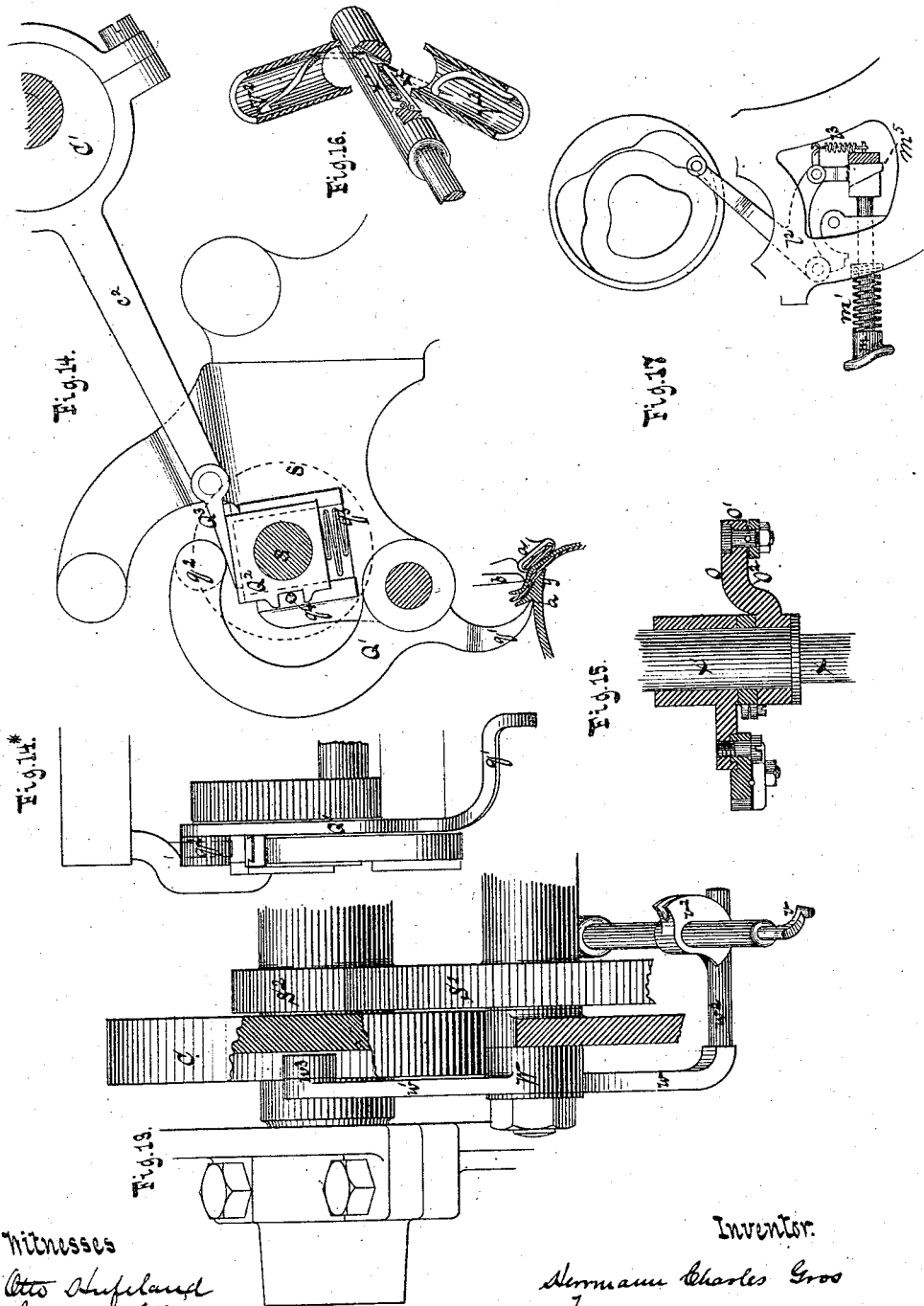

Witnesses
Otto Shufeland
Chas. Wahlers.

Inventor.
Normann Charles Gros
by Van Santvoord & Hauff
his attys.

H. C. GROS.
Boot and Shoe Sewing-Machine.
No. 206,317. Patented July 23, 1878.

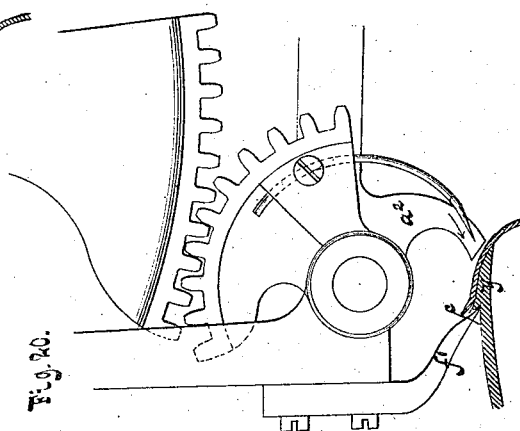
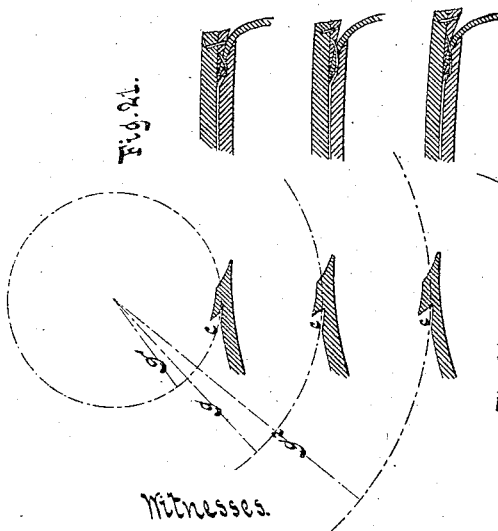
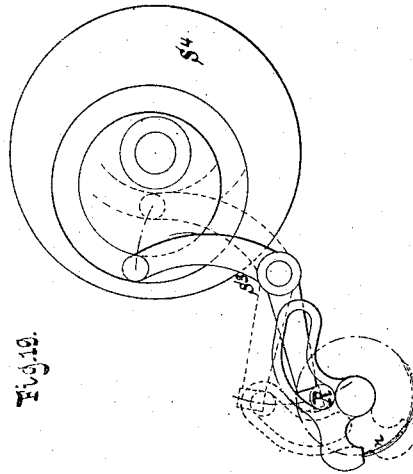
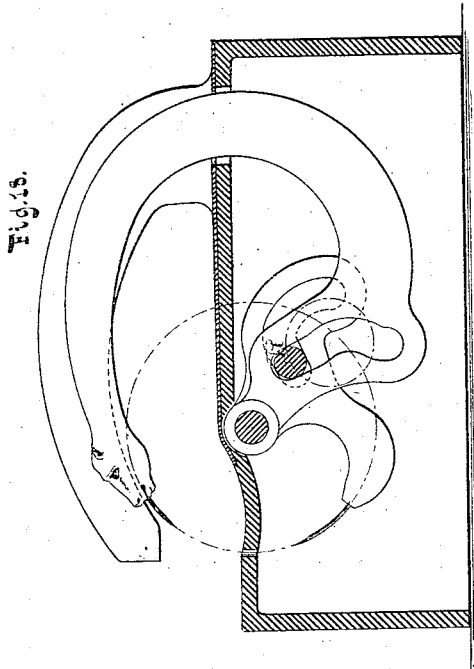

Witnesses.
Otto Shufelbine
Chas. Wahlers

Inventor.
Hermann Charles Gros
by
Van Santwood & Hauff
his attys

UNITED STATES PATENT OFFICE.

HERMANN C. GROS, OF REUTLINGEN, WÜRTEMBERG, GERMANY.

IMPROVEMENT IN BOOT AND SHOE SEWING MACHINES.

Specification forming part of Letters Patent No. 206,317, dated July 23, 1878; application filed March 28, 1878.

To all whom it may concern:

Be it known that I, HERMANN C. GROS, of Reutlingen, in the Kingdom of Württemberg and Empire of Germany, have invented a new and useful Improvement in Sewing-Machines for Boots and Shoes, reference being had to the accompanying drawings, in which—

Figure 1 represents a side elevation of a machine embracing my invention. Fig. 2 is a front view thereof. Fig. 3 is a plan or top view of the same. Fig. 4 is a front view of the feed mechanism, partly in section. Fig. 5 is a similar view of the tack-extractor. Fig. 6 is a plan or top view of the feed mechanism. Fig. 7 is a side view thereof, including the tack-extractor. Fig. 8 is a side view of the piercing and sewing mechanisms, and the mechanism for operating the looper, some parts being shown in section. Figs. 9, 10, and 11 are side views of the piercing and sewing mechanisms and looper, showing the parts in their different positions. Fig. 12 is a cross-section in the line *xx*, Fig. 11. Fig. 13 is a front view of the looper and its driving mechanism, partly in section. Fig. 14 is a side view of the mechanism for gaging the back movement of the needle. Fig. 14* is an end view thereof. Fig. 15 is a cross-section of the sewing and piercing mechanisms in the line *yy*, Fig. 8. Fig. 16 is a sectional perspective view of the devices for rotating the looper. Fig. 17 shows a modification of the mechanism for locking the auxiliary gage. Fig. 18 shows the sewing and piercing mechanisms applied to a machine for producing a vertical seam. Fig. 19 shows a modification of the mechanism for driving the wrist-pin. Fig. 20 shows portion of a machine as heretofore used. Fig. 21 shows specimens of work sewed on my machine.

Similar letters indicate corresponding parts.

My invention relates chiefly to that class of machines for sewing what are known as "turned boots and shoes;" also for sewing welts to the uppers of boots and shoes, and for stitching the soles to the welts, in which machines a curved barbed needle is used, either alone or in conjunction with an awl, the point of which works concentrically to the point of the needle.

My invention consists in certain novel combinations of parts, designed with a view to

obviate certain difficulties existing in the machines now generally in use, all of which is hereinafter fully described, and pointed out in the claims, a preliminary description being therefore deemed unnecessary.

In the preparation of insoles for welt-seams, as also of soles for turned work, a channel, *c*, is formed in the sole (see Figs. 20 and 21) at equal distances from its edge, to receive the seam and to form a guide for the work in the operation of sewing, the channel being made to receive, also, in machines now generally in use, the channel-gage or feed-dog, *f*. In those machines in which the needle or awl enters the work from the opposite side to the channel *c*, as indicated by the arrow in Fig. 20, the upward pressure on the work, as well as the piercing force of the needle or awl, is solely to be resisted by the channel-gage or feed-dog.

A result of this arrangement is that the feed-dog is often forced through the sole, or that the material between the chamfered edge of the sole and the channel *c*, known as the "between substance," and marked *y*, is torn away before even a hole is pierced. This difficulty was sought to be overcome by arranging the needle to pierce the inner or channeled side of the sole and using a back guide, the feed-guide being arranged to occupy a stationary position, and the back guide being made to yield, so as to adapt itself to the sinuosities of the work. Sufficient resistance, however, is not thereby offered to the force of the needle, and the arrangement is therefore defective.

I overcome the difficulties named by the arrangement of parts shown in Figs. 4 and 7—that is to say, I attach the back guide *a*, which is also arranged to form the welt-guide, to an arm, *a'*, forming a part of the machine-frame, so that the back guide is rigid or remains stationary during the operation of sewing. I also make use of a top rest or middle gage, *b*, which is attached to the arm *a'*, and is preferably made vertically adjustable, while it reaches down upon the between substance *y*, thus resisting the upward pressure on the work—that is to say, the pressure of the jack upon which the work is mounted—so that the function of the channel-gage or feed-dog *f*, in the present machine, is simply to feed the article to be sewed forward. When I add that, in the sew-

ing of welts and in the sewing of turned work, the awl (which works in the direction of the feed-dog) is generally dispensed with, the needle serving both as the piercing and the sewing instrument, it will be readily seen that the part *f*, formerly called the "channel-gage or feed-dog," and hereinafter termed a "feed-gage," is relieved of all, or nearly all, the pressure. Inasmuch as the work to be sewed has various thicknesses or shapes, the feed-gage *f* is arranged to vibrate or yield, and thus accommodate itself to sinuosities of the work. The feed-gage *f* acquires the requisite elasticity by its form; or, in other words, the spring is constructed as part of the feed-gage itself, the same being bent, as shown in Figs. 4 and 7, to form two shanks or legs, extending in a radial direction, or nearly so, to the axis of the needle-circle.

That shank of the feed-gage *f* which extends toward the work to be sewed is rebent, and forms the foot of the feed-gage *f* reaching into the channel *c*, while the other shank is secured to an oscillating lever, *F*, from which the feed-gage receives its motion. By arranging the feed-gage as stated, the point of yielding of its yielding or vibrating shank does not deviate from the path of the needle.

If desired, the two shanks of the feed-gage *f* can be made separately and connected by a hinge-joint, in which case a spring of suitable form is placed between them.

In order to permit of limiting the motion of the yielding or vibrating shank of the feed-gage *f*, I arrange an eccentric-disk, *d*, (best seen in Fig. 7,) on a suitable pivot at or near the lower end of the other or fixed shank. This eccentric-disk *d* bears against the vibrating or yielding shank of the feed-gage *f*, and is held in its different positions by the action of a spring, *d'*, which bears against one side of a polygonal head, *e*, which is secured to the pivot on which the eccentric-disk *d* turns, so as to turn with the latter. The adjustment of the eccentric-disk *d* is, under ordinary circumstances, effected by hand; but it may be obtained automatically, if found desirable.

It will be seen that, while I employ a stationary or rigid back guide, *a*, and a top rest, *b*, the above-described arrangement of the feed-gage *f* admits of its yielding freely to different substances and sinuosities of the work. Thus, while in former machines, with a rigid feed-dog and yielding back guide, the striking of the needle from the inside was not absolutely practicable, I achieve this object in a highly-satisfactory manner.

I employ a needle and awl, or a needle alone, having a radius of about two inches, (that being the medium between the two sizes ordinarily adopted,) whereby I obtain such a curve as will most accurately pierce the soles and insoles in the same direction as if the operation were performed by hand, and at the same time obtain sufficient space for the carrying out of other parts of my invention.

The needle *n* is situated in a curved socket

formed in the needle-stock *N*¹, and is held in position by means of a cover, which is secured to the needle-stock by suitable screws. The needle-stock *N*¹ is secured to an oscillating slotted lever, *N*, by means of a set-screw, *N*², passing through a slot which is formed in the needle-stock *N*¹ concentrically to the axis of the needle-circle, so that the needle-stock is adjustable, and at the same time always preserves the same relation to the needle-axis. If desirable, however, the needle-stock *N*¹ can be made in one piece with the slotted lever *N*. In the upper arm of the slotted needle-stock lever *N* is formed a cam-slot, *P*, which is so shaped that a wrist-pin or roller, *R*, fits into every portion of the same. This wrist-pin *R* is eccentrically secured to a rotating wheel, *S*, (or to a lever,) which wheel has its axis in proximity to the axis of the lever *N*, constituting the needle-axis, and above the same, as clearly shown in Fig. 8, the wheel being mounted on a shaft, *s*. The location of the wrist-pin *R* on the wheel *S* is such, relatively to the circle of motion of the needle, that in the rotation of the wheel about one half of the path through which the wrist-pin travels is within the needle-circle, while the other half thereof lies outside of the same.

When a continuous revolving motion is imparted to the wheel *S*, an oscillating motion is given to the needle *n* by the action of the wrist-pin on the slotted lever *N*; and I so arrange the wrist-pin in the slot *P* that when the needle recedes from the stuff to be sewed and draws a loop in the thread the wrist-pin is nearest to the needle-axis, so that the needle is caused to perform its retrograde movement with great rapidity, while just when the needle is about to pierce the stuff, and when the greatest power is required, the wrist-pin is at the greatest distance from the said axis, the leverage is increased, and the movement of the needle becomes comparatively slow.

If desired, the wrist-pin *R* may be made adjustable on the wheel *S*, to permit of varying the loop drawn by the needle.

The needle *n* slides in a needle-guide, *t*, which has a curved groove or hole for its reception. This guide *t* is so arranged, relatively to the motion of the needle, that when the needle pierces the work, as shown in Fig. 11, the guide bears on the work, and remains in this position till the needle recedes with the thread; but when the needle draws out, the thread goes back with the same. To the needle-guide *t* is secured the so-called "barb-protector" or "hook-shield" *t'*, whose function is to cover up the barb of the needle *n* when the latter recedes with a fresh loop, so that this barb-protector *t'* receives its motion from the same mechanism as the needle-guide *t*, and has a corresponding motion thereto. The compound needle-guide and barb-protector so formed is provided with a pin or projection, *t''*, (either plain or dovetailed) at its inner end, (see Figs. 8 and 12,) which is placed in one of two or more recesses formed in one arm of an

oscillating lever, T, and is clamped by means of set-screws; or in lieu of this arrangement the pin or projection t^2 may be held in its recess by means of a screw and eccentric-washer, it being so arranged that when this screw is loosened and the eccentric-washer turned in one direction the projection is free to pass out and in, whereas by inserting the projection in the desired recess, then turning the eccentric-washer in the other direction and tightening the screw, the whole is firmly held in position.

The object of providing two or more recesses for the reception of the pin or projection t^2 is to permit of adjusting the compound needle-guide and barb-protector t or t^1 correspondingly to the adjustment of the needle-stock or needle.

The lever T receives its motion in an analogous way to the needle-stock lever N—the lever T, namely, swinging on a common axis with the latter, side by side with the same, and being provided with a cam-slot, U, in its upper arm, embracing the wrist-pin R. A portion or one side of the slot U in the lever T is almost parallel to the slot of the needle-stock lever N, which portion of the slot U is pressed against the wrist-pin R during the upward motion of this pin by the action of a spring, u , which is connected to the lever T, whereby the compound needle-guide and barb-protector t t^1 is caused to move downward and to bear on the work when the needle pierces the same, as before stated.

That part or side of the slot U which is opposite to the one last named is cut away or enlarged concentrically to the axis of the wheel S, or nearly so, as at U^2 , and the lever T is constructed with a stop, u^2 , which, when the wrist-pin R reaches its highest point, comes in contact with a counter-stop, u^1 , which is preferably made adjustable, so that after the wrist-pin has reached its highest point and moves downward its action on the lever T ceases, during which time the combined needle-guide and hook-shield t t^1 remains stationary and bears on the work. The length of the slot U is such, relatively to the slot P in the needle-lever, that the compound needle-guide and barb-protector t t^1 remains stationary till the needle n has been forced through the work and recedes therefrom with a fresh loop. When the needle has stepped out of the work the wrist-pin R resumes its action on the lever T in the slot U, and the compound needle-guide and barb-protector t t^1 is caused to move back with the needle.

The foregoing portion of my specification applies to the sewing of welts and of turned work without the use of an awl, in both of which operations the seam-line of the work is vertically beneath the needle-axis.

I will now describe the application of my machine in producing the second seam, or in "doubling"—namely, in sewing the sole to the welt. During this operation the work receives a different position from the one named, the welt resting on a support reaching to the

needle-circle, and the sole lying in an inclined plane of about thirty or forty degrees, as indicated in Fig. 10, so that the workman is enabled to observe the seam, and to move or turn the work without difficulty. In this operation, moreover, it is necessary that an awl be used in conjunction with the needle to pierce the hole through which the needle passes.

In the practical carrying out of this operation heretofore a special machine was necessary, or such an alteration of the welt-machine had to be undertaken as to render the same almost unserviceable.

By my machine I am enabled to produce both seams in one and the same machine in a highly-satisfactory manner, and without material alterations, every change which is really necessary being susceptible of being made in a few minutes.

Referring to Fig. 10, I substitute for the aforesaid top rest or middle gage a bottom rest, b' , which reaches into the needle-circle, and stands at an angle of from thirty to forty degrees to a vertical plane taken through the needle-axis. I also remove the needle-stock N^1 from its forward to its rear position, as the same would otherwise be liable to strike against the work or the bottom rest, b' . It may be remarked in this connection that the needle-stock N^1 could be permanently arranged in its rear position by forming the same in one piece with the lever N, or otherwise; but in this case a needle of such length would be required as to lack the necessary stability. I further remove the compound needle-guide and barb-protector t t^1 from the forward recess in the lever T to the rear one, then take off the back guide, a , and the arrangement is completed—that is to say, the machine is adapted for doubling. To this operation, however, an awl is necessary, as above explained. To this end, I place side by side with the needle-lever N, so as to turn on the same axis therewith, a lever, O, which carries the awl-stock O^1 , in which the awl is fastened in any suitable way, and which is so arranged as to bring the awl in the same circle as the needle. This awl-stock lever O is constructed with a cam-slot, Q, which is made to embrace the wrist-pin R, so that this lever also receives its motion therefrom, the slot Q being so shaped as to produce the proper motion of the awl.

That part of the awl-stock lever O which forms the awl-stock O^1 is bent transversely, as clearly shown at O^2 , Fig. 15, so as to bring the awl-receiving socket in the awl-stock in a corresponding plane to the socket in the needle-stock N^1 for the reception of the needle, the effect of which is that the relative positions of the needle and awl points remain unchanged when a change is made in the needle or awl; or, in other words, the points of the two always meet. This result was difficult of attainment in former machines, whereas I effect the same in a simple and effective manner.

I arrange the awl-stock lever O correspondingly to the needle-stock lever N with rela-

tion to the wrist-pin R and the needle-axis—that is to say, so that the wrist-pin is farthest from the needle-axis when the awl pierces the work, and vice versa.

The wheel S, carrying the wrist-pin R, is provided with cogs on its periphery, and gears with a cog-wheel, S', (see Figs. 8 and 13,) which, in turn, gears with the cog-wheel S'', mounted on the main shaft of the machine. (Marked E.)

A modification of the means for driving the wrist-pin R is shown in Fig. 19, where the pin R is applied to one arm of an oscillating lever, S³, the other arm of which is provided with a stud, which engages with a cam-groove formed in a disk, S⁴, so that the wrist-pin receives a reciprocating motion, while it imparts an oscillating motion to the lever or levers which it carries.

When my machine is to be used for sewing materials of various different thicknesses with one and the same seam, I make use of a certain gage mechanism, which is shown in Figs. 14 and 14*, and whose action is such that when thick material is sewed the needle draws a longer loop or moves farther back than when thin material is sewed, the seam being thus drawn similarly tight throughout, while in the forward motion of the needle it always reaches the same point. This is accomplished by such an arrangement of parts that when thick stuff is sewed the wrist-pin R comes nearer to the needle-axis in its downward movement, during which movement the retrograde movement of the needle is thereby effected, than when thin stuff is sewed, while in the upward movement of the wrist-pin it always reaches the same height. To this end I place on a common axis with the aforesaid levers N O T an oscillating gage-lever, Q', the lower arm, q', of which forms the gage proper and reaches into the channel c of the work to be sewed, so that this arm or gage adjusts itself inward or outward, according to the thickness of the work. This movement is partaken of by the other arm of the lever Q, which is marked q², and which I term a "thumb-arm." This thumb-arm q² is bent so as to clear the bearing of the wheel S, which carries the wrist-pin R, as before stated, and said arm moves toward or away from this bearing, according to the thickness of the material to be sewed, the same being brought nearest thereto in the case of thick material.

The shaft s, around which the wheel S revolves, passes through a sliding box, Q², which moves in guide-grooves formed on the machine-frame, as shown in Fig. 14, and is subjected to the action of a spring, q³, having a tendency to force the same upward. The extent of movement of the sliding box Q² either upward or downward is regulated by a stop-pin, q⁴, which acts on suitable shoulders formed on the box.

Between the upper surface of the sliding box Q² and the end of the thumb-arm q² is interposed a reciprocating wedge, Q³. This wedge receives a reciprocating motion from an

eccentric, O', mounted on the main shaft E through a bar, C², which is connected both to the wedge and to the eccentric. The motion of the eccentric O' is so arranged that when the wrist-pin R (not shown in Fig. 14) moves upward the wedge Q³ is drawn back or out from between the sliding box Q² and the thumb-arm q², and the sliding box Q² is forced up to its full extent by the action of the spring q³. This upper position of the sliding box Q² being always the same, the needle, the extent of whose movement depends upon the position of this box, is always driven forward to the same extent. In the downward movement of the wrist-pin R, however, the wedge Q³ is shoved forward between the thumb-arm q² and the sliding box Q², and presses the latter inward to a greater or less extent, according to the position of the thumb-arm q², whereby the shaft s, together with the wheel S and wrist-pin R, is moved toward the needle-axis.

It will now be understood that when thick stuff is sewed the wrist-pin R moves nearest to the needle-axis, the needle moves back to the greatest extent, and the longest loop is drawn, and vice versa.

In Fig. 18 I have shown the manner in which that part of my invention relating to the mechanism for driving the awl and needle is applied to such machines in which a vertical seam is produced and in which an awl is used for piercing the material.

The thread is conducted from any usual or suitable apparatus to a looper or thread-guide, v, (best seen in Fig. 8; see also Figs. 9, 10, 11,) by which it is carried around the end of the needle, and hung in the barb of the latter, as indicated in Fig. 11. This looper is secured to the end of a shaft, V, and has a rotary motion around the point of the needle; and, inasmuch as the needle moves forward farther in piercing than in doubling, (the needle, being moved farther back during this latter operation, as before stated,) while it is necessary to hang the thread in the barb of the needle in either case, the looper v, besides having rotary motion around the needle, also has a reciprocating sliding motion in a tangential direction to the needle-circle. When the needle penetrates the material to be sewed the looper v stands back and below the needle-circle, as shown in Fig. 8. Before the needle, however, has completed its forward motion the looper v begins its sliding motion in the direction of the needle, and at the same time the shaft V of the looper turns, so that the thread is carried around the protruding portion of the needle, and is caught by its barb, so as to follow the needle in its retrograde movement. In the operation of piercing the thread is laid somewhat beyond the barb of the needle, whereas in doubling the thread is just caught by the barb or hook. The looper v remains in the position last stated till the needle has drawn the thread through the between substance p; when it begins to move back, the same being also caused to rotate in its return

movement, so as to clear the awl or its stock, (when an awl is used,) which latter in the meantime will have begun its movement.

The motion of the looper is produced in the following manner, referring to Figs. 8 and 13: The shaft V of the looper passes through the main frame B in an inclined direction, and on the same is secured a grooved segment or head, v' , in which catches a pin, w^2 , projecting from the lower arm, w , of a lever, W. This lever is arranged on the shaft s , and receives an oscillating motion from a cam-groove formed in one side of a disk, C, mounted on the main shaft E, the upper arm, w' , of the lever W being provided with a roller, w^3 , which is fitted in said cam-slot.

The pin w^2 moves in a guide-slot, w^4 , formed in the machine-frame B, as shown in Fig. 8. By this means I impart a reciprocating sliding motion to the looper v or its shaft; and I make use of this motion to produce the rotary motion of the looper, as follows:

The shaft V is surrounded at or near its rear end, at which point it is preferably enlarged or strengthened, by a sectional or two-part sleeve, $V^2 V^3$, (see Figs. 8 and 16,) which is fitted and secured in a bearing, V^1 , arranged on the rear part of the machine-frame. In each section of said sleeve $V^2 V^3$ is formed a groove or slot, as shown, the groove in the upper section, V^2 , extending in a spiral direction throughout its length, while the groove in the lower section, V^3 , extends lengthwise of the sleeve through a part of its length and spirally through the remainder, the spiral part of this groove having a greater inclination than the groove in the section V^2 . In said grooves of the sleeve-sections $V^2 V^3$ are fitted the bent ends of two inwardly-yielding arms, x^1 and x^2 , which are located in a recess formed in the shaft V, and are pivoted at their inner ends, as at 1 and 2, said arms being, moreover, subjected to the action of a spring, x , having a tendency to press the same apart or outward. I can also use two inwardly-yielding pins in lieu of the arms x^1 and x^2 .

When the shaft V moves in the direction of the arrow in Fig. 8, and the arm x^1 engages with the spiral groove in the upper sleeve-section, V^2 , the shaft is caused to turn on its axis by the action of such groove. During this movement of the shaft V the other arm, x^2 , bears against the plain inner surface of the lower sleeve-section, V^3 , or, in other words, is out of engagement with its groove; but when the shaft V has completed its entire forward motion, this arm x^2 falls into its groove in the sleeve-section V^3 , and thus produces the backward-rotating motion of the shaft, the rectilinear portion of the groove in said lower section, V^3 , causing the shaft to go through a portion of its rear movement without rotation, and the arm x^1 being at the same time brought out of play, to which end the groove in the sleeve-section V^2 is made to vanish on the inner surface of the latter. I thus cause the

shaft V and the looper to rotate both in their forward and backward movements.

By the groove in the lower sleeve-section, V^3 , the looper v is caused to rotate in a different direction when it moves backward than when it moves forward, and thus clears the awl or its stock.

The feeding of the work is accomplished through the hereinbefore-named feed-gage f , whose movement is such that it grasps the material to be sewed at the moment when the needle begins to pull back the thread, and then moves laterally in the direction of the length of the needle-axis, so as to carry the work with it. When it has arrived at the point where the awl or needle pierces the material, the feed-gage f remains stationary until the needle begins its retrograde movement, when the gage releases the work and moves backward. To this end the feed-gage f is attached to the lower arm of a lever, F, (see Figs. 4, 6, and 7,) which has a common axis with the needle and awl levers, and the upper arm of which is connected to the outer end of a horizontal reciprocating rod, G, which slides in bearings $g^1 g^2$ affixed to the machine-frame, the bearing g^1 being slotted in a horizontal direction, and the bearing g^2 being arranged on a pivot, so that it is susceptible of rotation. The object of this arrangement is to permit the rod G to follow the feed-lever F in its lateral movement—namely, its movement lengthwise of the needle-axis.

On the inner end of the reciprocating rod G is arranged a roller, H, which bears on a cam, D^1 , formed on the circumference of a disk, D, mounted on the main shaft E, and the rod is held in contact with this cam by the action of a spring, g , coiled thereon, as clearly shown in Fig. 7.

When the cam D^1 revolves it imparts a reciprocating motion to the rod G, whereby the lever F is oscillated and the feed-gage f is caused to grasp and release the work.

I prefer to make the reciprocating rod G adjustable in length, so as to admit of a variation in the position of the feed-gage with respect to the stationary back guide a and adapt the parts to different thicknesses of material.

In the example shown, I accomplish this object by making the reciprocating rod G in three sections, which are connected by a right and left hand screw, so that by simply turning the central section the rod can be lengthened or shortened. I also connect the feed-lever F to the rod G in such a way that the lever can be adjusted outward or inward. This adjustment adapts the feed-gage f for welt-sewing or for doubling, as the case may be.

The fulcrum of the feed-lever F is formed by a bar, X, which extends through a sleeve, which is secured to the machine-frame, and on which the awl and needle levers are mounted, as shown in Figs. 9, 10, 11, 12. Above this bar X, and parallel thereto, is situated a bar, Y, which is arranged in a tubular bearing on the ma-

chine-frame. Both these bars are connected together at their opposite ends by cross-rods y^1 and y^2 , so that the whole forms a parallelogrammic frame, which is susceptible of a horizontally-sliding motion.

The feed-lever F , while being allowed to swing freely around the axis of the lower bar, X , is placed between two shoulders, so that it has no independent lateral motion on the lower bar, but travels to and fro together with such bar.

The cross-rod y^1 carries a slotted plate, Z , which is secured thereto by means of a pivot, z^2 , and a thumb-screw, z^3 , so that it is adjustable. This plate Z is adjusted to such a position that its slot extends in an oblique direction, the degree of which is increased or diminished according to the extent to which it is desired to feed the work, or, in other words, according to the length of the stitch to be made.

Into the slot of the plate Z projects one end of a lever, Z^1 , which oscillates on the shaft s^1 , and is provided with a roller, z^1 , which is fitted in said slot. At its other end this lever Z^1 is provided with a roller, z^2 , which is fitted in a cam-groove, Z^2 , formed in one side of the disk D .

When the disk D revolves the lever Z^1 is oscillated, and the roller z^1 is caused to move up and down in the slotted plate Z , whereby a lateral motion is imparted to the parallelogrammic frame, before mentioned, and by means thereof to the feed-gage f .

In all machines now generally in use the upper is lasted to the insole during the process of sewing by iron tacks, which are drawn out just before the work is sewed and replaced by fine copper tacks, which are pressed aside or cut up by the needle or awl.

I apply to my machine a contrivance for extracting the tacks by which the upper is lasted to the insole, as stated, whereby the expenditure of time and money involved in the use of copper tacks is obviated.

For this purpose I make use of a claw, J , (see Figs. 4 and 7,) the shank of which is pivoted in a slot to the machine-frame, as at i , and is secured to one arm of the lever Z^1 , while it extends in such a direction that when in its normal position the claw rests on or immediately above the work, as shown in Fig. 7.

When the work is fed or moved forward the tacks are caught by the claw J , and when the lever Z^1 is oscillated the claw is raised, so as to extract the tacks, and then returned to its normal position, the tack being thrown out of the claw in its descent.

I will now describe how the work is held during the process of sewing.

Referring to Figs. 1, 2, and 3, the jack L^4 , for carrying the last, rests on a horizontal bar, U^1 , which is preferably bent upward near its opposite ends, so as to give it a **U** shape, as shown in Fig. 2, and it is susceptible of a swinging motion, the same being suspended

from a rope, M' , which is connected thereto at its extremities. The object of giving the bar U^1 a **U** shape is to bring the points at which it is hung as nearly as possible in a horizontal plane with the point where the sewing takes place, whereby increased facility is obtained for guiding the work.

The rope M' extends from either end of the bar U^1 over a pulley, K , or K^1 , thence downward and over pulleys $L^1 L^2$ or $L^2 L^3$, and, finally, around a pulley, K , from which is suspended a weight, M , so that by the latter an upward pressure is exerted on the bar U^1 as well as on the jack and the last which it carries, which has the effect of maintaining the work in contact with the sewing mechanism without the aid of the operator, leaving him free to turn the work about as required, according to its shape or contour, as the operation proceeds.

It is obvious that a spring can be substituted for the weight M .

The jack L^4 is pivoted to the bar U^1 , as shown, so that the same is capable of any desirable motion in a horizontal direction, thus enabling the workman to turn the work as he sees fit.

When the work is moved in the direction of length of the last, the bar U^1 partakes of this movement; and, in order to obviate the liability of a disengagement of the cord M' with the pulleys K K^1 during this movement, the latter are mounted in horizontally-swiveled frames K^2 K^3 , projecting from brackets K^4 K^5 , which are secured to the bearing of the main shaft E .

The work to be sewed also rests against an auxiliary gage, m , (see Fig. 1,) which is provided with a broad perpendicular face, and is attached to one end of a shaft, m^1 , which passes through the center line, or nearly so, of the machine-frame, having its bearing therein, and is pressed against the work by a spring, m^2 . The shaft m^1 of the gage carries a loose collar, m^2 , which extends within the frame, and is provided with a flange, n^2 , while it is divided or slotted about midway of this flange. The flange n^2 rests with its lower surface upon a bearing firmly attached to the machine-frame, and upon its upper surface acts a lever, l , which bears upon the flange and compresses the collar m^2 , so as to lock the gage-shaft m^1 when the needle or awl is performing its function, whereas the lever is lifted, so as to release the collar, when the auxiliary gage is to yield to the shape of the work.

The lever l is pressed upon the flange n^2 by the cam-surface of the disk D , on which the upper arm of the lever, which is provided with a roller, bears, while the lever is lifted by the action of the spring l^1 , connected thereto. The locking of the auxiliary gage can also be accomplished by a wedge, m^3 , as shown in Fig. 17, this wedge being arranged in contact with an incline arranged at the rear end of the gage-shaft m^1 , and being connected to a lever, l^2 , which is actuated by a suitable cam, against which it is pressed by a spring, l^3 , so

that at the requisite periods the wedge m^3 is brought in contact with the incline and withdrawn, so as to lock and release the gage.

What I claim as new, and desire to secure by Letters Patent, is—

1. In a boot and shoe sewing machine, the combination of the stitch-forming devices, the rigid combined back and welt guide a , yielding feed-gage f , and oscillating lever F , and mechanism, substantially as described, for operating said lever, substantially as and for the purposes set forth.

2. The combination of the stitch-forming devices, the combined back and welt guide a , top rest b , and yielding feed-gage f , lever F , cam D , and connecting mechanism, substantially as described, and the feed-operating mechanism, as set forth.

3. The combination, with the reciprocating needle and work-guiding devices of a boot and shoe sewing machine, of a yielding feed-gage adapted to yield in the arc of a circle parallel with and at one side of the path of the needle, substantially as and for the purpose set forth.

4. In a boot or shoe sewing machine having a curved barbed needle, the combination of a feed-gage, f , which is constructed with two shanks, and extends radially to the needle-axis, with the feed-lever F , substantially as described.

5. In a boot or shoe sewing machine having a curved barbed needle, the combination, with the oscillating slotted lever N , of a needle-stock which is adjustable concentrically to the axis of the needle-circle, substantially as specified, so that the point of contact of the needle with the work can be altered without altering the position of the lever, substantially as described.

6. In a boot or shoe sewing machine having a curved barbed needle, the combination of an oscillating lever, T , one arm of which carries the compound needle-guide and barb-protector t t' , and the other arm of which is provided with a cam-slot, U , with a wrist-pin which is fitted in said cam-slot, and mechanism for giving motion to said wrist-pin, the whole being adapted to operate substantially as described.

7. The combination of the oscillating lever T , provided with the compound needle-guide and barb-protector, and the cam-slot U , having the segmental enlargement U^1 and stop u^2 , with the counter-stop u^1 , spring u , and wrist-pin R , substantially as described.

8. The combination, with the oscillating lever T , of a needle-guide, t , which is adjustable concentrically to the axis of the needle-circle, substantially as specified, so as to occupy the proper position relatively to the needle, substantially as described.

9. The combination of the oscillating lever T , substantially as specified, provided with the radial sockets, as shown, with the needle-guide t , provided with a shank adapted to fit and be

inserted into either of said sockets, as required, for the purpose set forth.

10. The combination, with the oscillating needle-stock lever N , the needle-guide lever T , and awl-stock lever O , of a wrist-pin, R , arranged to communicate motion to said levers from the main shaft of the machine, substantially as described.

11. The combination, with the oscillating needle-stock lever N and oscillating awl-stock lever O , having the needle and awl secured thereto, respectively, and provided with the cam-slots P and Q , of the wrist-pin R , arranged relatively to the needle-axis, substantially as described, so that said wrist-pin is nearest to said axis when the needle or awl is out of the work, and farthest from said axis when the needle or awl pierces the work, as and for the purpose set forth.

12. The combination, with the oscillating needle-stock lever N of the awl-stock lever O , each having a cam-slot, substantially as described, of the wrist-pin R , mechanism, substantially as described, for operating the same, said wrist-pin projecting through both of said cam-slots, and mechanism, substantially as described, for controlling the position of the wrist-pin in relation to the axes of said levers, whereby when thick stuff is being sewed the needle has a different or longer retrograde movement than when thin stuff is sewed, while in its forward movement the needle always reaches the same point, as set forth.

13. The combination, with the wrist-pin R and the axis on which it turns, of a sliding box, Q^2 , spring q^2 , stop q^4 , reciprocating wedge Q^3 , eccentric C , connecting-bar c , and gage-lever Q^1 , all adapted to operate substantially as described, and for the object specified.

14. The combination, in a sewing-machine, of the reciprocating curved barbed needle and the looper v , and mechanism for actuating the same, whereby a compound reciprocating and rocking motion is imparted thereto, substantially as and for the purpose set forth.

15. The combination, with the stitch-forming mechanism of a sewing-machine, of the longitudinally-reciprocating looper v and mechanism, substantially as described, whereby a different rotary motion is given to said looper on its return from that imparted to it on its forward movement.

16. The combination of the looper v , its shaft V , the head v' , the lever W , the sectional sleeve V^2 V^3 , and its spiral grooves, the inwardly-yielding arms or pins x^1 and x^2 , and the spring x , all adapted to operate substantially as described.

17. The combination, with the oscillating feed F , of a longitudinal reciprocating rod, G , slotted bearing g^1 , pivoted bearing g^2 , and spiral spring g , all adapted to operate substantially as and for the purpose described.

18. The herein-described mechanism for producing the lateral motion of the feed-lever and feed-gage, consisting of the horizontal par-

allel bars X Y, the cross-rods $y^1 y^2$, the oblique slotted plate Z, and the lever Z¹, and the cam for operating said lever, the whole being combined and adapted to operate substantially as described.

19. The combination, with the vibrating lever Z and feeding mechanism, of the claw J, substantially as described.

20. In a boot or shoe sewing machine having a curved barbed needle, the combination, with the feed and sewing mechanism, of a swinging support composed of the jack L⁴, horizontal

bar U¹, rope M¹, connected to said bar, the pulleys K K¹ L L¹ L² L³, and the weight M or its equivalent, the whole being combined and adapted to operate substantially as described.

In testimony that I claim the foregoing I have hereunto set my hand and seal this 20th day of February, 1878.

HERMANN C. GROS. [L. S.]

Witnesses:

JNO. E. GARDIN,
R. M. JACKSON.