

L. F. SMITH.
Steam-Trap.

No. 206,361.

Patented July 23, 1878.

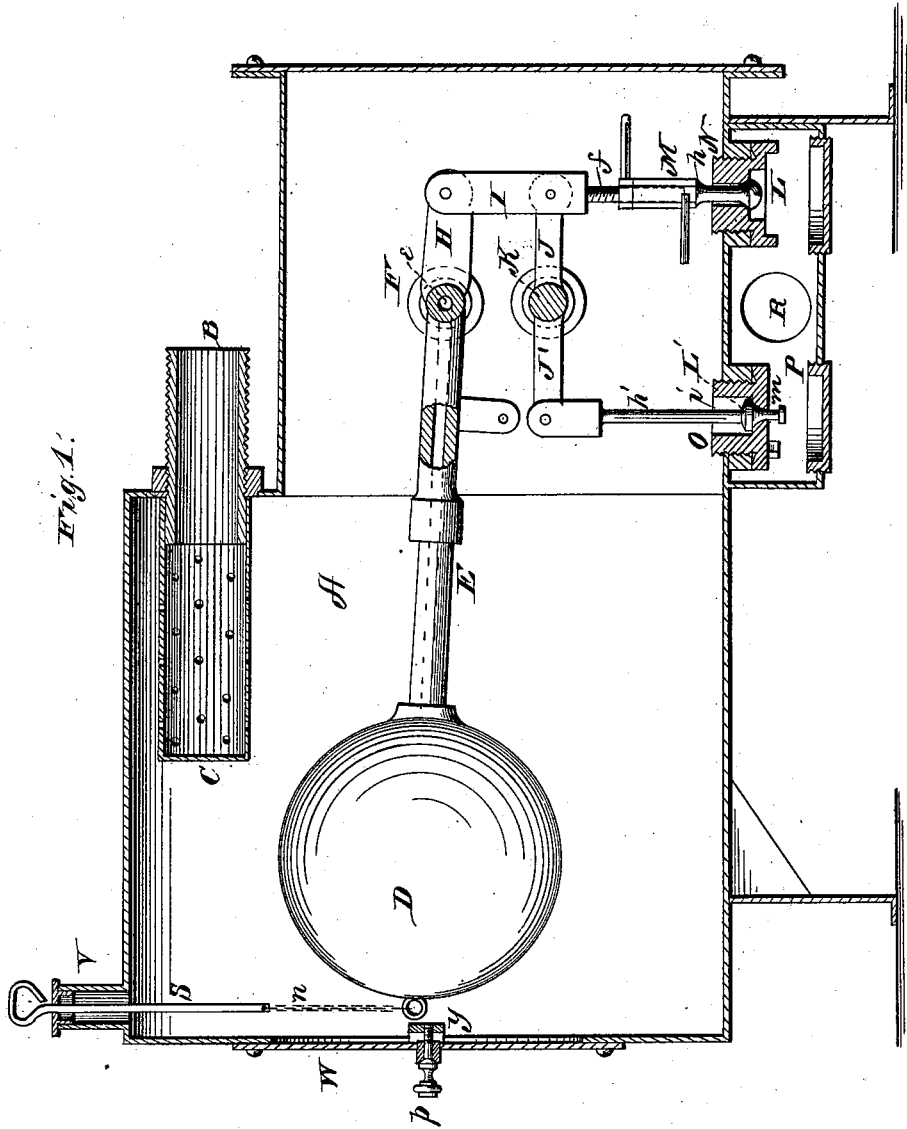

WITNESSES
Frank L. Outland
J. J. Mc. Carthy

BY

INVENTOR
Levi F. Smith
Alexander Mason
ATTORNEYS

L. F. SMITH.
Steam-Trap.

No. 206,361.

Patented July 23, 1878.

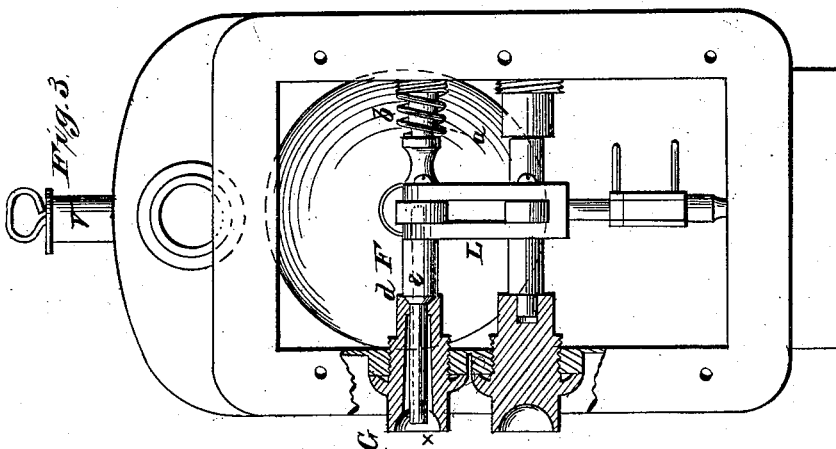
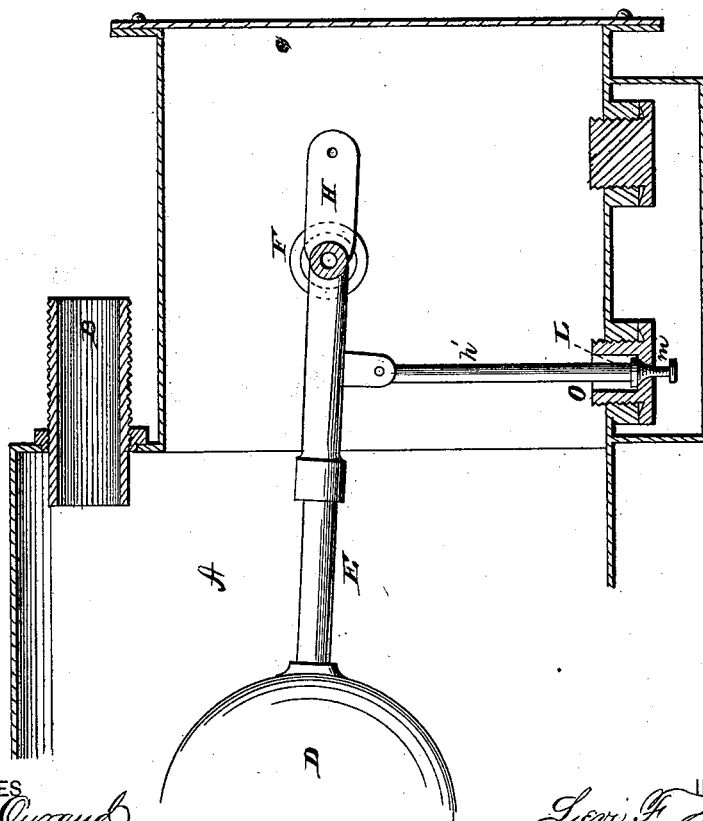

Fig. 2.



WITNESSES
Francis L. Curran
J. J. McCarthy

BY

INVENTOR
Louis F. Smith
Alexander Mason
ATTORNEYS

UNITED STATES PATENT OFFICE.

LEVI F. SMITH, OF PHILADELPHIA, PENNSYLVANIA.

IMPROVEMENT IN STEAM-TRAPS.

Specification forming part of Letters Patent No. **206,361**, dated July 23, 1878; application filed June 13, 1878.

To all whom it may concern:

Be it known that I, LEVI F. SMITH, of Philadelphia, in the county of Philadelphia, and in the State of Pennsylvania, have invented certain new and useful Improvements in Steam-Traps; and do hereby declare that the following is a full, clear, and exact description thereof, reference being had to the accompanying drawings, and to the letters of reference marked thereon, making a part of this specification.

The nature of my invention relates to the construction of steam-traps in which a hollow ball or float is made to operate one or more valves; and it consists in certain peculiarities of construction, as will be hereinafter more fully set forth, and pointed out in the claims.

In order to enable others skilled in the art to which my invention appertains to make and use the same, I will now proceed to describe its construction and operation, referring to the annexed drawings, in which—

Figure 1 is a longitudinal vertical section of a steam-trap with two valves embodying my invention. Fig. 2 is a section of a steam-trap with one valve embodying my invention. Fig. 3 is a transverse vertical section of Fig. 1 through the axis of the float-lever.

A represents the case or body of the trap, provided with the horizontal inlet-tube B near the top. The inner end of this inlet-tube is provided with a tubular strainer, C, as shown, so as to distribute the water as it passes from the steam-pipes, instead of allowing the same to pass into the trap in a stream over the float.

D represents the hollow ball or float, which is attached to a hollow stem or lever, E. This stem or lever may be made in one or two pieces, as desired, and at its outer end it is provided with a shaft or journal, F, extending at right angles with it on both sides. One end of the shaft F is made to fit over a stud, *a*, in the side of the trap, and a spiral spring, *b*, surrounds said stud and bears against the end of the shaft. The other end of the shaft F projects through a hollow plug, G, fastened in that side of the case A, as shown in Fig. 3. On this end of the shaft, at a suitable point, is formed a beveled shoulder, forming a ground joint at *d*, with a corresponding seat formed in the inner end of the hollow plug G. This part of the shaft F has a longitudinal passage,

e, extending from its end inward, and communicates with the interior of the hollow stem or lever E. By this means a vent is formed for the hollow ball or float D, so that, in case any moisture, by condensation or otherwise, should be formed on the inside of the float, it will by the heat be evaporated and pass out through the lever E and shaft F.

The spring *b* keeps the ground joint *d* tight, and if from any cause this joint should stick, and thus prevent the float from working, it is only necessary to press upon the end of the shaft F, when the joint will open and the water and steam will blow out, removing all obstructions. As soon as the pressure on the end of the shaft is removed the spring *b* throws it outward again, closing the joint. The outer end of the hollow plug G is recessed, as shown at *f*, and the end of the shaft F projects into said recess, so as to be protected from any accidental knocks, and yet be free for the application of inward pressure, as described.

From the shaft F extends an arm, H, in a line with the lever E, and the outer end of this arm is, by a stirrup, I, connected with an arm, J, projecting from a rocking shaft, K, having its bearings in the sides of the trap, below the shaft F.

The bearings for the shaft K, as well as the stud *a*, above mentioned, are formed in screw-plugs, which are screwed into the sides of the trap.

From the lower end of the stirrup I projects a screw, *f*, which, by a screw-coupling, M, is connected with the stem *h* of the valve L for adjusting the same, said valve being arranged to open downward from its seat N, as shown.

The rock-shaft K is provided with a forwardly-projecting arm, J', to which the stem *h'* of the valve L' is connected. This valve opens upward from its seat O, and the two valves balance each other, one working up and the other down.

The seat O for the valve L' is formed on its upper side with a cup or recess, *i*, in which said valve plays, and below the seat the valve is formed with a head, *m*. These parts perform a very important function in the operation of the trap.

As the condensed steam rises in the trap the float D rises with it, and when it reaches a certain height the valve L opens downward,

and the valve L' at the same time opens upward, and the water passes out into the chest P below, and from the same through suitable exits R. By the fall of the water the float also descends, and gradually closes the valves L L', the recess *i* in the seat O and the head *m* on the valve L' aiding in closing the valves. If these parts were not there the rush of the water and steam would have a tendency to lift the valve L', or, rather, to keep it in a raised position; but, by the addition of the recess *i*, the water is compelled to come on top of the valve, and also on top of the head *m* below, whereby the tendency is to close the valve, instead of, as sometimes happens, keep the float suspended until all the water has escaped, and afterward by the steam.

In many cases the valve L can be entirely dispensed with, and the stem of the valve L' is then connected directly to the float-lever E, as shown in Fig. 2.

A chain, *n*, is connected to the float D and attached to a rod, S, which passes upward through a stuffing-box, V, on top of the trap. This is simply for the purpose of raising the float, and thereby open the valves to allow all the water to pass out instead of having any remaining standing in the trap.

In the head W of the trap is an air-valve, *p*, connected to a bulged cross-bar, Y, having both ends fastened to the head. When the trap is cold the valve *p* is open, and will allow the air to pass out as the hot water and steam enter the trap. As the trap then becomes hot the bar Y expands and tightly closes the air-valve *p*.

Having thus fully described my invention,

what I claim as new, and desire to secure by Letters Patent, is—

1. In a steam-trap, the valve-seat O, with recess *i*, and the valve L', working within the recess and provided with the head *m* below the valve-seat, in combination with the stem *h'*, float D, and lever E, substantially as and for the purposes herein set forth.

2. In a steam-trap, the combination of the float D, lever E H, stirrup I, rock-shaft K, with arms J J, valve L, and seat N, and the valve L' with head *m* and seat O, with recess *i*, substantially as and for the purposes herein set forth.

3. The combination, in a steam-trap, with the hollow float D and hollow lever E, of the shaft F, having one end solid and supported on a stud, *a*, with spring *b* to act thereon, and the other end of the shaft hollow and forming a ground joint, *d*, with the hollow plug G, substantially as and for the purposes herein set forth.

4. In a steam-trap, the combination of the hollow float D, with hollow stem E, the hollow ground joint shaft F, with arm H, the stirrup I, rock-shaft K, with arms J J', valve L', with head *m* and stem *h'*, and the valve-seat O, with recess *i*, all constructed substantially as and for the purposes herein set forth.

In testimony that I claim the foregoing I have hereunto set my hand this 12th day of June, 1878.

LEVI F. SMITH.

Witnesses:

FRANK GALT,
J. M. MASON.