

BEST AVAILABLE COPY

H. A. TAYLOR & A. MUIRHEAD.
Telegraphic Accumulators and Condensers.

No. 206,366.

Patented July 23, 1878.

Fig 1.

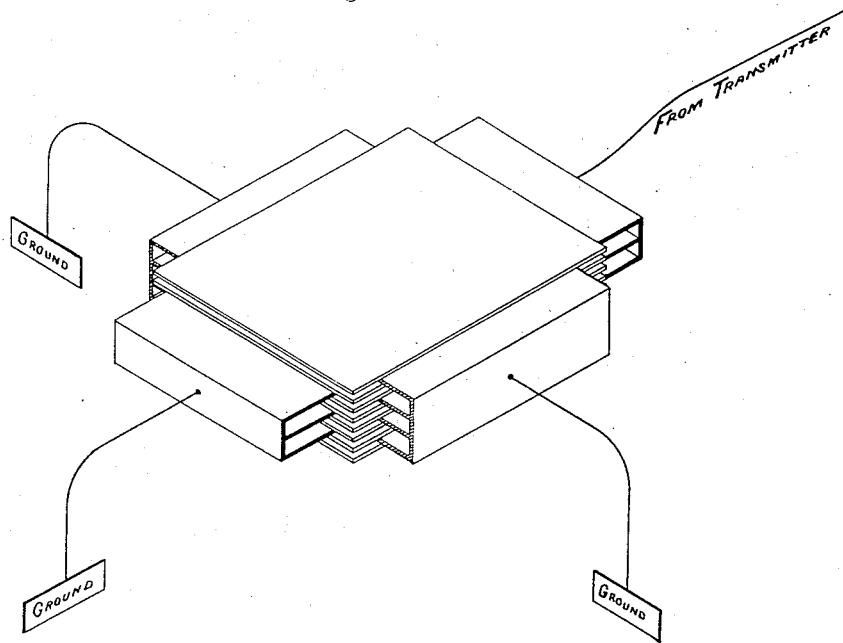

Fig 2.



WITNESSES

Wm A. Skunkle
Geo. W. Orick

INVENTORS

Herbert A. Taylor.
Alexander Muirhead
By their Attorneys
Baldwin, Hopkins & Peyton

UNITED STATES PATENT OFFICE.

HERBERT A. TAYLOR, OF CORNHILL, LONDON, AND ALEXANDER MUIRHEAD,
OF 159 CAMDEN ROAD, MIDDLESEX COUNTY, ENGLAND.

IMPROVEMENT IN TELEGRAPHIC ACCUMULATORS AND CONDENSERS.

Specification forming part of Letters Patent No. 206,366, dated July 23, 1878; application filed
May 15, 1878; patented in England, February 24, 1875.

To all whom it may concern:

Be it known that we, HERBERT ARNAUD TAYLOR, of 7 Pope's Head Alley, Cornhill, in the city of London, and ALEXANDER MUIRHEAD, of 159 Camden Road, in the county of Middlesex, England, have invented new and useful Improvements in Electric Telegraphs and in apparatus connected therewith, which improvements are fully set forth in the following specification.

This invention has for its object to construct an accumulator having also power of conduction, which is adjusted to the requirements as in Muirhead's English Patent No. 3,663, of October 23, 1874, upon which this is an improvement. The subject-matter claimed is hereinafter stated.

With paper-pulp is mixed a substance, such as black lead (plumbago) or precipitated metals, gold, silver, copper, or other good conducting substance, by which a moderate conducting power is imparted to the paper produced from the pulp, or by chemical processes conducting materials may be precipitated in the body of the paper. The paper so prepared is arranged between alternate layers of a dielectric, which may consist of paper treated with paraffine wax or shellac, of gutta-percha or mica. In accumulators thus prepared the conducting-paper takes the place, partly or in whole, of the metallic sheets (tin-foil or lead) hitherto generally employed.

To form the imitation telegraph-line this conducting-paper, insulated, as in the condenser, by sheets of a dielectric material, is so arranged by connecting a number of the sheets, either in continuous or parallel circuit, that the electrical properties of the telegraph line or cable are imitated, so that uniformly throughout the imitation line the conductive resistance bears the same ratio to the electrostatic capacity as the resistance (either total or per unit of length) of the telegraph line or cable bears to its electrostatic capacity.

Paper made as above described may be used in constructing standards of high resistance.

We obtain a paper which contains intimately intermixed with the pulp a conducting-powder. Plumbago we prefer. The paper we have used, and which works well, contains about fifty per cent. of plumbago. It is of the sub-

stance of stout blotting-paper, and we obtain it in sheets about eleven by eighteen inches; but other sizes, of course, may be obtained if required. The plumbago is mixed with the paper-pulp in the same way as other powders have sometimes been introduced, with a view to give substance to the paper. When this paper is to be used in conjunction with paraffine paper, we apply, in order to render it less porous, a weak solution of shellac in alcohol, either by dipping or brushing; but this is unnecessary when shellacked paper is used for the insulator. We also obtain sheets of a suitable dielectric. Paper saturated with paraffine wax we employ by preference. We also obtain sheets of a material which is a good conductor of electricity. We employ tin-foil by preference. We place these sheets the one on the other in the following order: Paraffine paper, tin-foil, paraffine paper, plumbago paper, paraffine paper, tin-foil, paraffine paper, plumbago paper, and so on until we have accumulated as many sheets as we think desirable—say, for example, we use twenty sheets of plumbago paper. The pile will then consist of eighty-three sheets in all. The sheets of plumbago paper are (if we intend the conduction to be along the length of the paper) made longer than the paraffine sheets—say, by an inch and a half, or thereabout—so that one sheet of plumbago paper comes into contact with another sheet of the same material at the margin all along each end; and to hold the sheets tightly together along these margins we pass copper rivets through them. The sheets of paraffine paper are somewhat wider than the plumbago paper, so that they effectually prevent the sheets of plumbago paper coming into contact the one with the other, except at the margins, as already stated. The sheets of tin-foil are smaller than the sheets of paraffine paper, so as to insure that they shall be kept out of contact with the plumbago paper; but the sheets of tin-foil or tongues projecting from them are allowed to come into contact one with the other at one or both sides remote from the projecting margins of the plumbago paper.

It is advisable to put the sheets together when the paraffine is hot, and to press them between hot plates of metal from time to time

as the sheets are accumulated, so that the paraffine sheets may adhere closely together all round except where the projecting parts or tongues of the tin-foil come between them. This completes the construction of one unit or section of the artificial line or balancing apparatus.

To form a complete artificial line or balancing apparatus a number, more or less considerable, of such units are combined the one with the other by connecting their riveted margins in such a way as to establish a good electric communication between them, and when the instrument is in use one end of the artificial line or balancing apparatus may be connected with the transmitter and the other to earth, while the sheets of tin-foil have a direct earth connection. This is the arrangement we prefer when the cable has a direct connection with the transmitter and with the receiving-instrument; or if, as is now very usual, condensers are interposed at both ends between the cable and the instruments, we make similar arrangements in respect to the artificial or balancing line. When the cable is worked on other systems the connections will be varied to suit the particular system in use, as will be well understood by electricians, the object being in all cases to assimilate as closely as possible the conditions under which the actual and the imitation cable are worked.

If we desire to make an artificial line or balancing apparatus to work with an existing telegraph-cable of which the resistance and capacity are known, we can so construct one unit as to represent both in resistance and capacity a given length of cable, and then it is only necessary to couple up these units in continuous circuit to correspond to the entire length of the cable; but in other cases it is

convenient to make the units with comparatively high resistance as compared with the capacity, and then, by arranging the units in parallel circuit, a balancing arrangement or artificial line can be readily arranged corresponding approximately to any cable likely to be met with in practice, the resistance being dependent on the dimensions and arrangement of the plumbago paper and the capacity or power of condensation or extent of surface of the tin-foil which faces it.

These instruments are not only useful in duplex telegraphy but also for other purposes, such as the experimental working of telegraphic transmitting and receiving instruments.

Having thus described the nature of the said invention and the manner of performing the same, we would have it understood that we claim—

The construction of artificial lines or accumulators having also power of conduction by combining the following parts: first, conducting-strips of paper prepared with plumbago or other conducting material, by which the current passes through the instrument; second, metal foil or other conducting material having an earth connection, through which it charges and discharges itself; third, separating sheets of dielectric or insulating material, the whole arranged substantially as described.

London, 20th December, 1877.

H. A. TAYLOR.
ALEX. MUIRHEAD.

Witnesses:

CHAS. BERKLEY HARRIS,

JOHN DEAN,

Both of 17 Gracechurch St., London, E. C.