

H. B. TODD.
Sad-Iron.

No. 206,369.

Patented July 23, 1878.

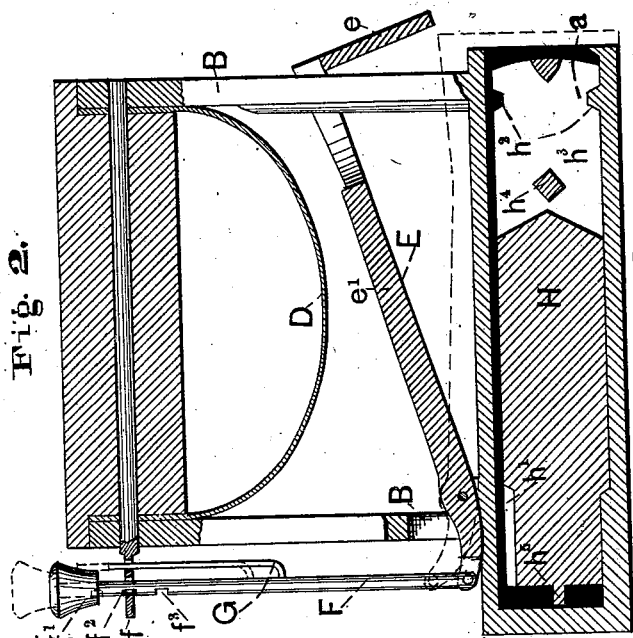

Fig. 2.

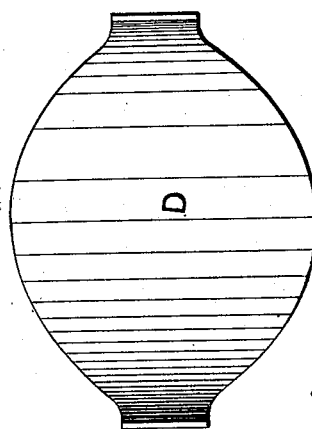

Fig. 4.

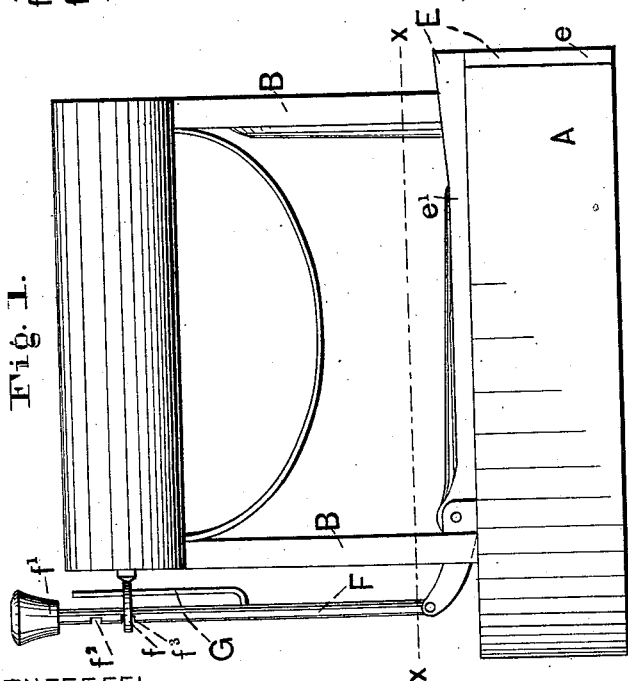

Fig. 1.

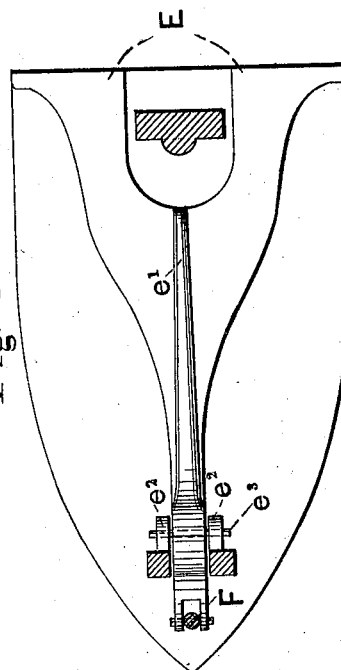

Fig. 3.

WITNESSES:
J. S. West
Cornelius Cox

INVENTOR:
HENRY B. TODD,
BY
H. W. Beadle & Co.
ATTYS.

H. B. TODD.
Sad-Iron.

No. 206,369.

Patented July 23, 1878.

Fig. 5.

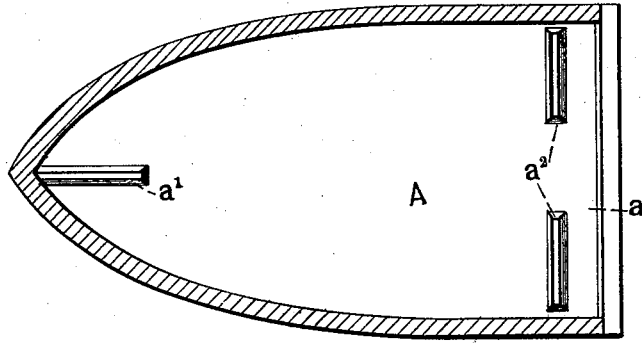

Fig. 6.

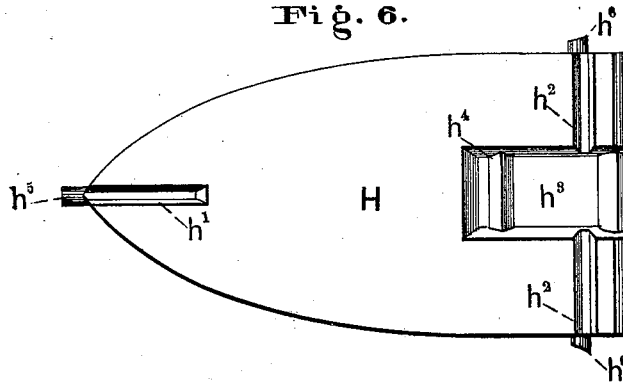

Fig. 7.

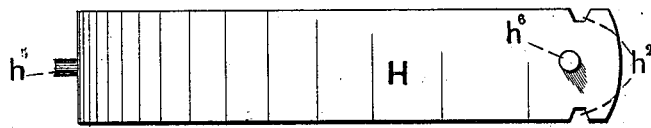
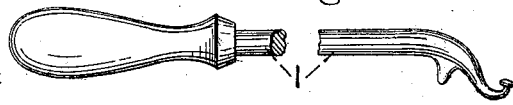

Fig. 7a.

WITNESSES:
J. S. West
Cornelius Cox



INVENTOR:
HENRY B. TODD,
BY
H. W. Beadle & Co.
ATTYS

UNITED STATES PATENT OFFICE.

HENRY B. TODD, OF WEST MERIDEN, CONNECTICUT.

IMPROVEMENT IN SAD-IRONS.

Specification forming part of Letters Patent No. 206,369, dated July 23, 1878; application filed May 14, 1878.

To all whom it may concern:

Be it known that I, HENRY B. TODD, of West Meriden, county of New Haven, State of Connecticut, have invented new and useful Improvements in Sad-Irons; and I do hereby declare that the following is a full, clear, and exact description of the same, reference being had to the accompanying drawings, and to the letters of reference marked thereon.

This invention relates to that class of sad-irons in which a shell or box, forming the iron proper, is employed in connection with a removable heating-block; and consists in certain peculiar details of construction by means of which certain imperfections in the ordinary irons are remedied, and certain special advantages are obtained, as will be fully described hereinafter.

In the drawings, Figure 1 represents a side elevation of my improved iron; Fig. 2, a vertical sectional elevation of the same, the space about the heater being shown in solid black; Fig. 3, a transverse section on the line $x x$, Fig. 1; Fig. 4, a plan view of the shield detached; Fig. 5, a transverse section of the box or shell; Fig. 6, a plan view of the heating-block removed, and Fig. 7 a side elevation of the same.

To enable others skilled in the art to make and use my invention, I will now proceed to describe fully the manner of constructing and using the same.

A, Figs. 1 and 5, represents the box or shell, constructed generally in the usual form, but essentially provided with the opening a , Fig. 5, at its rear end, and the projections $a^1 a^2 a^3$ upon the inner face of its bottom plate, as shown.

B B, Figs. 1 and 2, represent standards or arms rising from the upper plate of the iron in the usual manner, which support the usual handle C in any proper manner.

D, Figs. 2 and 4, represents a shield of any proper material and suitable size, which is suspended below the handle C, as shown, for the purpose of protecting the hand of the ironer from the heat of the iron.

E, Figs. 1, 2, and 3, represents the door for closing the rear opening of the shell, consisting of the flap or drop portion e , Figs. 1 and 2, adapted in size and shape to close the opening a , Fig. 5, when in its proper position, and

the lever portion e^1 pivoted near its front end between the standards or cars e^2 by means of the pin e^3 , as shown. The rear end of the lever portion, it will be observed, is bifurcated to pass the rear standard B, and is united at its extreme edge to the upper edge of the flap portion e , the two parts lying at right angles to each other, as shown. The front ends of the lever portion are also bifurcated to form a vertical recess for the lower end of the actuating-rod.

F, Figs. 1 and 2, represents the rod, united at its lower end to the front end of the lever portion e^1 of the door, and properly supported above by the guide ear or plate f , projecting from the handle G, as shown. f^1 represents any proper knob or handle attached to the upper end of the rod, and $f^2 f^3$ catch-notches, by means of which and the guide-ear f the handle may be secured in either its upper or lower position for the purpose of holding the door open or shut.

G, Figs. 1 and 2, represents a spring of any proper construction, by means of which, when adjusted in either position, the actuating-rod may be securely held against accidental displacement.

H, Figs. 2, 6, and 7, represents the heating-block, corresponding in its general outline with the shell or box A, designed to receive the same, which is essentially provided with the recesses $h^1 h^2 h^3$, corresponding in form and position with the projections $a^1 a^2 a^3$, as shown.

h^4 , Figs. 2 and 6, represents a vertical opening through the block, and h^4 a transverse bar located in the vertical center of said opening, near one end, as shown.

h^5 , Figs. 2, 6, and 7, represents a pin located at the point of the block, and $h^6 h^6$, Figs. 6 and 7, pins located on the sides of the block, near its rear end, the purpose of which is to center the block in the shell while new, and before it becomes swelled by the heat, after which they may be removed by breaking them off.

Each face of the heater is constructed alike, so that it may be used either side up.

I, Fig. 7^a, represents a lifter of any proper construction for removing the hot block H from the fire and inserting it in the shell, and for removing it from the shell and inserting it in the fire.

The operation is substantially as follows: The block H, having been properly heated in the fire, is removed by the lifter and inserted into the shell, the door having been opened for the purpose. When the block is properly in place, the recesses of the same will coincide with the projections upon the bottom plate of the shell, and hence the former will be securely held in its place, and not be permitted to slide about and knock against the ends and sides. After the block is in place the door may be closed by simply swinging the actuating-rod in a rearward direction upon its pivot against the action of the spring G sufficiently far to disengage its upper notch from the guiding-car, when the door, being no longer supported, will fall by its own weight properly into place.

The door is so hung, it will be observed, as to tightly close the opening when it swings to place, and thus effectually prevent the escape of heat. The door may be raised at any time when it is desired to remove the heater by simply depressing the knob of the actuating-rod until the upper notch of the same is caught by the guiding-car.

Some of the advantages of the described construction are as follows: The heating-block when in place is securely held in its proper position, so that the noise caused in other irons by the knocking of the block against the sides and ends is avoided.

By means of the peculiar construction of the door a joint is obtained which will not be affected by the expansion resulting from the

heat, but will remain equally tight under all circumstances.

The operation of the door also in opening and closing is convenient and easy.

I do not confine myself to the form of projections and recesses shown. If desired, they may be round, instead of oblong. If desired, also, the projecting points h^5 h^6 may be employed to hold the heater from sliding in the shell.

Having thus fully described my invention, what I claim as new, and desire to secure by Letters Patent, is—

1. In combination with the drop-door, moving in a vertical plane and having a lever-arm pivoted at one end to the iron, an actuating-rod, substantially as described, for moving the lever-arm.

2. In combination with the drop-door and connecting-lever, the actuating-rod, having notches f^2 , the spring G, and plate f , substantially as described.

3. In a sad-iron, a drop-door at the rear thereof attached to an arm pivoted near the front of the sad-iron, and operated by a parallel projecting thumb-lever, substantially as shown and described.

This specification signed and witnessed this 2d day of May, 1878.

HENRY B. TODD.

Witnesses:

E. A. MERRIMAN,
LESLAND H. IVES.