

W. M. WATSON.
Metallurgic Furnace.

No. 206,374.

Patented July 23, 1878.

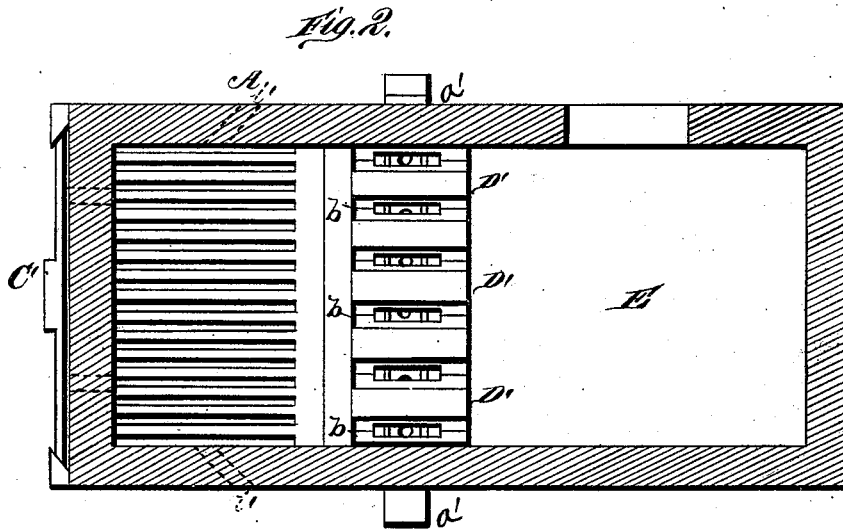
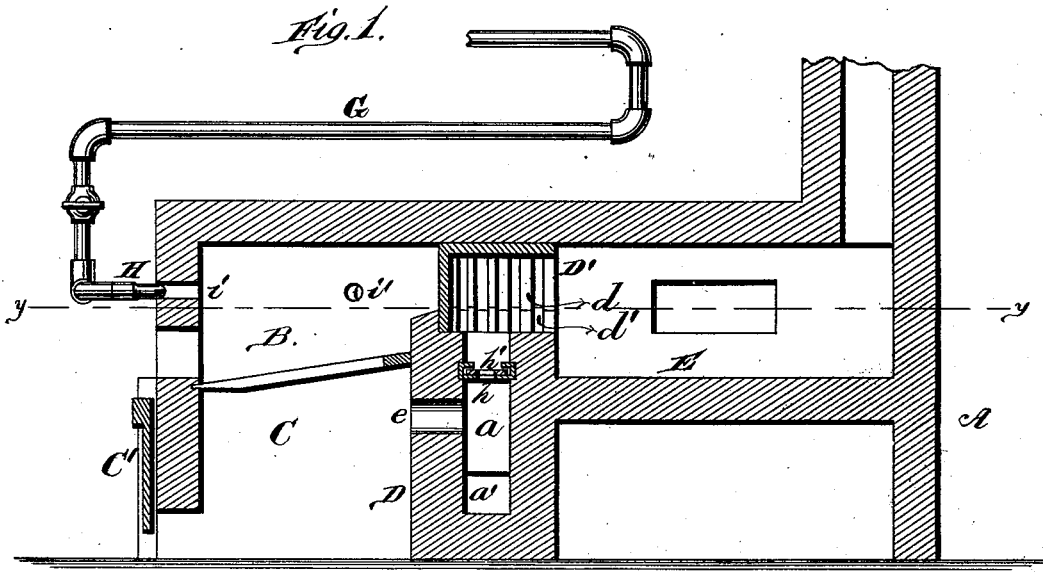

WITNESSES
Robert Ematt
George E. Upham.

INVENTOR.
William M. Watson.
Gilmore, Smith & Co.
ATTORNEYS.

W. M. WATSON.
Metallurgic Furnace.

No. 206,374.

Patented July 23, 1878.

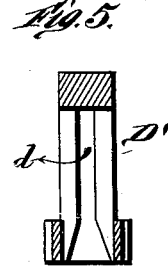
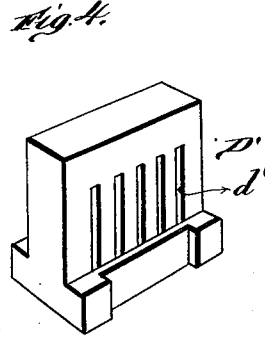
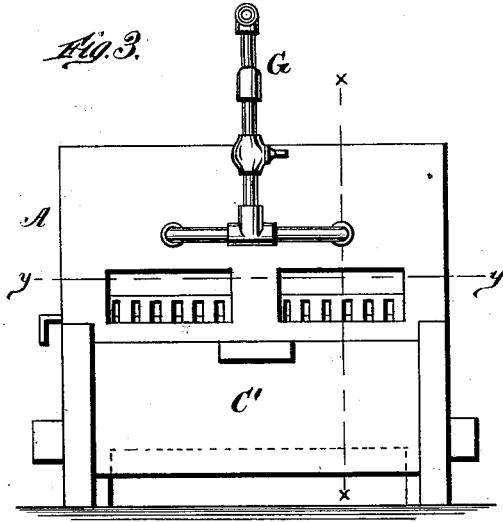

WITNESSES
Robert Conitt
George E. Upham

INVENTOR,
William M. Watson.
Gilmore, Smith & Co.
ATTORNEYS.

UNITED STATES PATENT OFFICE.

WILLIAM M. WATSON, OF TONICA, ILLINOIS.

IMPROVEMENT IN METALLURGIC FURNACES.

Specification forming part of Letters Patent No. **206,374**, dated July 23, 1878; application filed November 3, 1877.

To all whom it may concern:

Be it known that I, WILLIAM M. WATSON, of Tonica, in the county of La Salle and State of Illinois, have invented a new and valuable Improvement in Metallurgic Furnaces; and I do hereby declare that the following is a full, clear, and exact description of the construction and operation of the same, reference being had to the annexed drawings, making a part of this specification, and to the letters and figures of reference marked thereon.

Figure 1 of the drawings is a representation of a longitudinal vertical section of my furnace through line *x x*, Fig. 3, and Fig. 2 is a horizontal sectional view through line *y y*, Fig. 3. Fig. 3 is an end view; Fig. 4, a perspective detail, and Fig. 5 a sectional detail.

My invention relates to metallurgic furnaces of the class for which Letters Patent No. 191,209 were granted to me May 22, 1877; and it consists in certain improvements upon such furnace, as will be hereinafter more fully set forth, and pointed out by the claim.

The annexed drawings, to which reference is made, fully illustrate my improvement.

A represents the walls of the furnace; B, the fire-chamber, with ash-pit C underneath. D is the bridge-wall, with central passage, *a*, and provided with a series of horizontal passages, *b*, which are formed by means of partitions *D'*.

E is the hearth, which may be either stationary or revolving, as may be desired.

The partitions *D'* may be made of either metal or fire-clay, and are made hollow from the bottom upward for a suitable distance; or, in other words, each partition *D'* is formed with an interior chamber, *d*, open at the bottom, and from said chamber air-passages or openings *d'*, of suitable size and number, lead through the sides and rear end, to allow the air to mix more thoroughly with the flame and gases than can be done otherwise. If desired, these openings may be in the form of a series of round holes, and the end may be open and the side holes closed.

The row of partitions *D'* is intended to extend in the furnace over the hollow bridge-wall D from one wall to the other, as shown in Figs. 1 and 2 of the drawings.

The air is admitted into the passage or chamber *a* in the bridge-wall through a series

of holes, *e*, made through said bridge-wall immediately under the grate-bars, where the air is the hottest. In the air-chamber *a* is placed an air distributor and regulator, consisting of two plates, *h* and *h'*, both perforated with a series of holes of suitable size, and at proper distances apart, said plates extending the whole length inside the bridge-wall from side to side. The lower plate, *h*, is stationary, while the upper plate, *h'*, is movable, and made to slide over the lower plate, *h*, in such a manner as to open or close the holes in said plate, and thus let in a greater or less amount of air as may be required to burn the smoke properly without cooling the fire.

If desired, the air-distributor may be placed over the holes *e*, outside of the bridge-wall, under the grate-bars, and the holes made the proper distance to receive it.

The front of the ash-pit C is provided with a vertically-sliding door, *C'*, for the purpose of admitting the proper quantity of air to burn the coal without, on the one hand, having too much, and thus cool the fire, or, on the other, too little to burn the coal.

It is a matter of great importance, in the present improved construction of the furnace, that the admittance of cold air can be regulated.

In combination with the air arrangement, as above described, I supply steam above the grate-bars, to assist the air in consuming the smoke and improving the draft. The steam is conducted from a steam-generator through pipes G, arranged in any suitable manner through a gas-burner, H, having a slit in the end of the nipple or other suitable device to properly distribute the steam over the fire, and in direct line with the division-wall immediately above the bridge-wall. These burners or nozzles H may be inserted through holes *i i*, drilled through the fire-front above the doors; or they may enter through holes *i'* from each side at the rear of the grate-bars, these latter holes being inclined, so as to direct the steam toward the door.

At each end of the air-chamber *a* in the bridge-wall is an opening, *a'*, through the wall of the furnace, closed by a plug or other suitable means, for the purpose of allowing the ashes to be cleaned out when required.

I am aware that a steam-boiler has hereto-

fore been provided with a number of perforated chambers placed in the rear of the grate-bars, and supplied with air and steam from a boiler to assist in burning the smoke.

What I claim as new, and desire to secure by Letters Patent, is—

The combination, substantially as hereinbefore described, in a metallurgic furnace, of the single bridge-wall D, having the central passage or chamber, *a*, and a series of air-holes, *e*, communicating with said chamber through the bridge-wall immediately below the grate-

bars, an air distributor and regulator, and the divisions D', having interior chambers *d* and air-passages *d'*, as and for the purposes set forth.

In testimony that I claim the above I have hereunto subscribed my name in the presence of two witnesses.

WILLIAM MEDD WATSON.

Witnesses:

HENRY GUNN,
CYRUS GUNN.