

J. C. WHITE.
 Bobbin-Winder for Sewing-Machines.

No. 206,375.

Patented July 23, 1878.

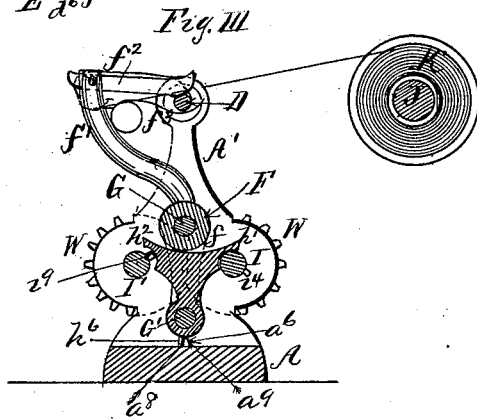
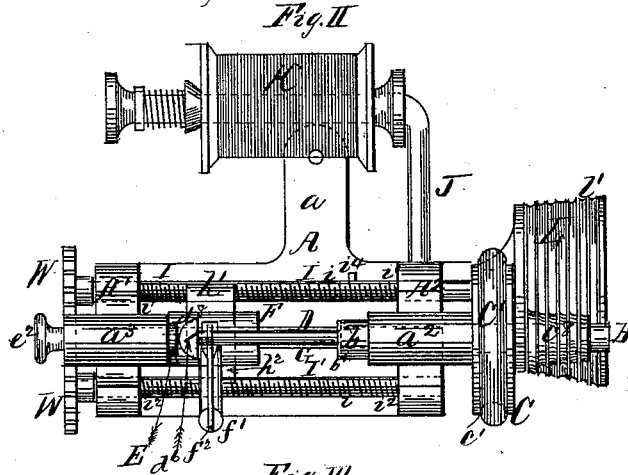
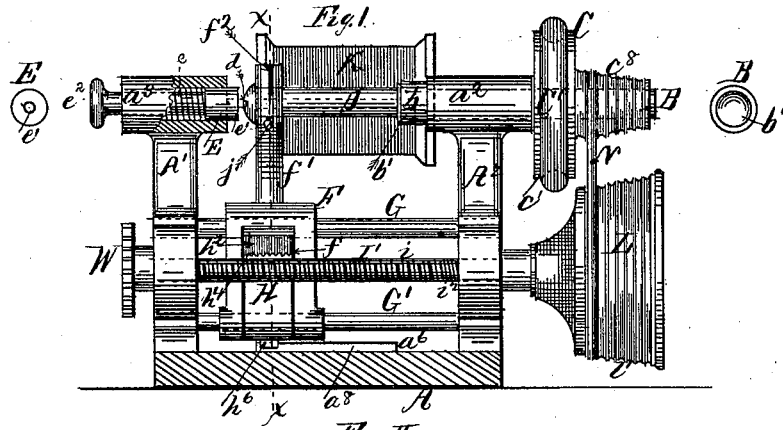

Witnesses:
 T. BARKER
 P. H. Mulgrew.

Inventor:
 Joseph C. White
 Per: J. Barnitt,
 Atty.

UNITED STATES PATENT OFFICE.

JOSEPH C. WHITE, OF NEW YORK, N. Y.

IMPROVEMENT IN BOBBIN-WINDERS FOR SEWING-MACHINES.

Specification forming part of Letters Patent No. **206,375**, dated July 23, 1878; application filed November 21, 1877.

To all whom it may concern:

Be it known that I, JOSEPH C. WHITE, of the city, county, and State of New York, have invented a new and useful Improvement in Bobbin-Winders for Sewing-Machines; and I do declare that the following is a clear and exact description of the same, reference being had to the accompanying drawings, forming a part of this specification.

The object of my invention is to produce a winder that shall wind any grade of cotton thread upon the bobbins of sewing-machines in the same uniform manner as it is now wound upon spools.

The machine is so constructed that it can be attached to any of the principal sewing-machines now in use.

Referring to the drawings, Figure I is a front view of my invention. Fig. II is a plan view of the same. Fig. III is a sectional view taken on line *x x*, Fig. I.

Letter A represents the bed-plate, having the lug *a* and the two uprights or standards $A^1 A^2$, all of which are made of metal. The lug *a* is provided with a hole, through which a bolt passes to secure the winder to the bed of the sewing-machine. (Not shown.) The tops of the standards $A^1 A^2$ are provided with the journal-bearings $a^2 a^3$. In the bearing a^2 revolves the axle B, having on its inner end a hub or collar, *b*, which serves a twofold purpose: first, to assist in holding said axle in its place; second, to hold one end of the bobbin D, for which purpose it is provided with a cavity, *b'*, as shown in Fig. I. To the other end of axle B is keyed a pulley, C, which has a groove, *c'*, in which is placed the rubber friction-ring *C'*.

When it is desired to give motion to the winder, this pulley C is placed against the fly-wheel of a sewing-machine, the rubber ring affording sufficient friction to cause said pulley to rotate.

The other bearing, a^3 , on standard A^2 , carries the stem E, which is forced inward by the spring *e*. The inner end of this stem is provided with a cavity, *e'*, in which is placed and permitted freely to rotate the axle or pivot *d* of the bobbin D. The other end of the stem E has a knob, *e^2*, by the aid of which the said

stem can be drawn outward, so as to place a bobbin in the winder.

By this arrangement the bobbin is easily attached and detached, and firmly held in the winder while it is being filled.

F is a sliding frame or block, supported and sliding upon the rods G G', which are held in the standards $A^1 A^2$. The lower part of this sliding block is provided with an opening, *f*, in which is placed the reversible follower or mover H, provided with arms h^1 and h^2 , extended out from the block F. This follower is supported upon the rod G', and also allowed to slide and oscillate upon the same.

The outer and under sides of the arms $h^1 h^2$ are semicircular in shape, (see Fig. III,) and are provided with screw-threads h^4 , which correspond with the threads *i* on the worm-shafts I I', which have their journals $i^1 i^2$ in the standards $A^1 A^2$. The object of these worm-shafts is to give motion to the sliding block F, which is accomplished by bringing either of the arms $h^1 h^2$ of the follower down upon either of the shafts I I'.

To hold either of the arms $h^1 h^2$ down upon the said shafts, I form on the under side of the follower H a lug, h^6 , which is intended to slide on either side of a guide-piece, a^6 , formed upon the top of the bed-plate A. The length of this guide-piece is or must be according to the length of the bobbin.

It is obvious that when arm h^1 is on shaft I the lug h^6 is on side a^6 of guide-piece a^6 , and in consequence thereof the arm is held firmly down upon the shaft. The same is true when arm h^2 is on shaft I', with the difference that lug h^6 is on side a^9 of the guide-piece.

To the top of the sliding block F is fastened the bent arm f^1 , which is intended to carry the thread-guide f^2 and spring-presser f^3 . The object of this presser is to hold the thread firmly upon the bobbin while being wound upon the same, so as to prevent displacement, and also to give uniformity of thickness to the different layers of thread.

J is an arm, fastened to one of the standards, for holding the spool of cotton or thread K, which is to be held on said arm in the same manner as it is usually held on the sewing-machine.

To the outer end of the worm-shaft I is keyed a conical pulley, L, which receives its motion from the conical hub or pulley C, on shaft or axle B, through the intermediary of a belt, N.

As there are different grades of cotton, it is necessary, therefore, that the speed of the worm-shafts I I', and consequently the movement of the sliding block F, should vary accordingly; and to accomplish this, I make the hub C' and pulley L conical in shape, (see Figs. I and II,) and cut around the circumference of said hub and pulley a number of grooves, c^3 and v . The number of these grooves will be governed according to the different grades of cotton to be used.

Motion is given to worm-shaft I' from shaft I through the cog-wheels W W, placed, respectively, on shafts I I'.

The operation of my machine is as follows: First place the bobbin D between the hub or shoulder b and stem E, as shown in Figs. I and II. Then place the sliding block F in the position shown in Fig. I. Pass the thread of cotton from spool K through the hole j in arm J, also over the guide f^2 , and then fasten it to the bobbin by passing it through the slot d^6 in the head d^3 . The machine is now ready to move.

As motion is communicated to the wheel C, as before stated, the bobbin is caused to rotate, and also the worm-shafts I I'. Motion is likewise given to the sliding block F by the shaft I, acting upon the arm h^1 of the follower H. The movement of this block is just enough to permit the thread of cotton to be wound uniformly upon the bobbin.

When the sliding block has traveled the length of the bobbin, the arm h^1 is lifted from the shaft I by the pin or lug i^4 on said shaft,

which movement causes the lug h^6 (which, during the movement of the sliding block, has been on side a^3 of guide-piece a^6) to be shifted to side a^3 , and the arm h^2 to be thrown over to and held down upon the shaft I', which, rotating in an opposite direction, will cause the sliding block to move in an opposite direction across the bobbin.

When the sliding block has again traveled across the bobbin, the arm h^2 is lifted from shaft I' by pin i^3 , and the lug h^6 again shifted to side a^3 , and the arm h^1 again brought down upon shaft I, where it was when the machine was set in motion.

By this arrangement the thread of cotton is automatically wound in uniform layers upon the bobbin.

Having thus described my invention, I desire to claim—

1. The sliding block F, provided with the arm f^1 , spring-presser f^3 , guide f^2 , and opening f , substantially as and for the purpose set forth.

2. The follower H, provided with the arms h^1 h^2 and lug h^6 , in combination with the worm-shafts I I', with pins i^4 i^3 , guide-piece a^6 , and sliding block F, substantially as and for the purpose set forth.

3. The worm-shafts I I', provided with pins i^4 i^3 and cog-wheels W W, in combination with the follower H, having the arms h^1 h^2 and the sliding block F, substantially as and for the purpose set forth.

This specification signed this 13th day of November, 1877.

JOSEPH C. WHITE.

Witnesses:

FREDK. B. SWIFT,
CH. RIEGELMAN.