

J. YOUNG.  
Metallic-Fence.

No. 206,384.

Patented July 23, 1878.

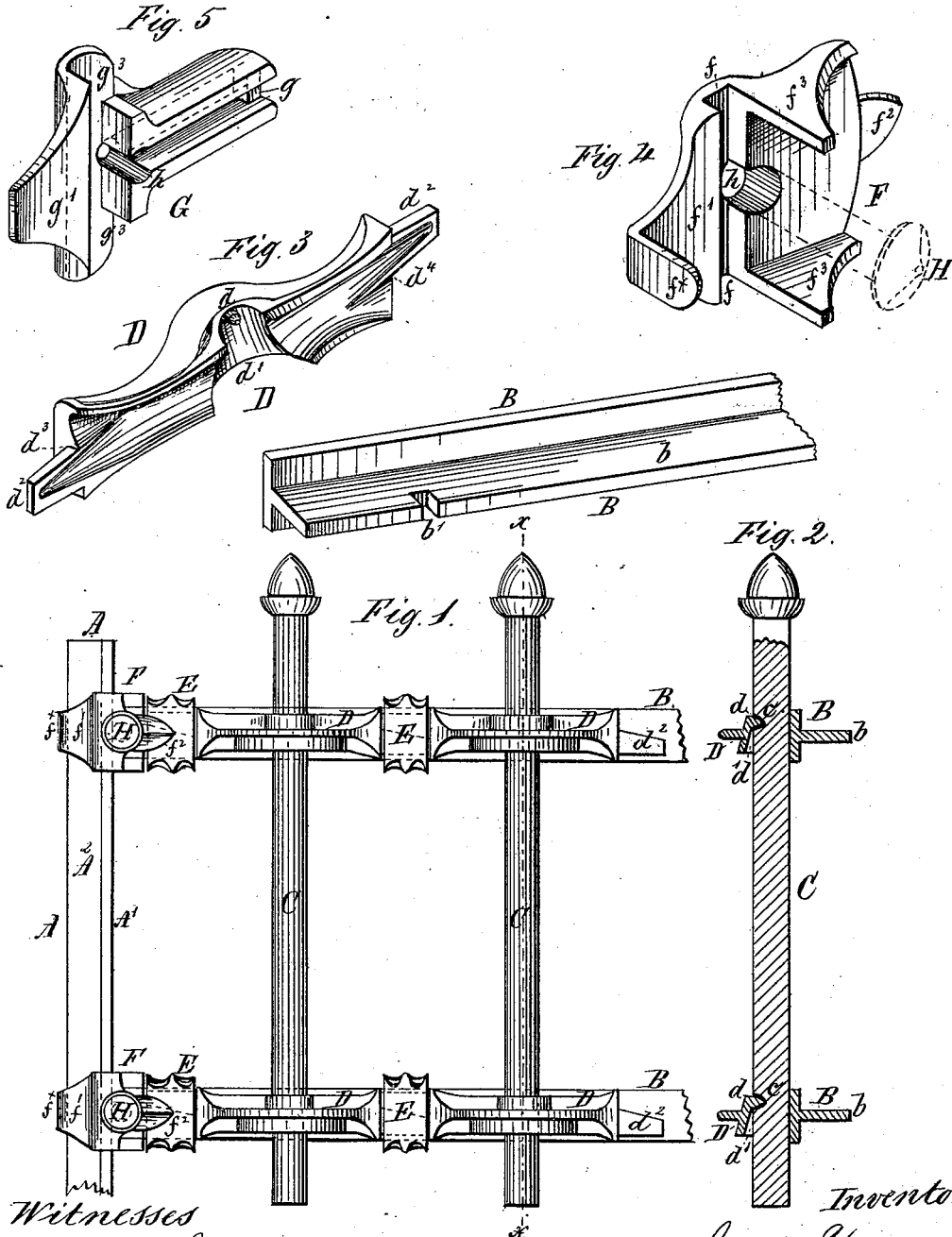

Witnesses  
*Alf. L. Leonard*  
*Henri Guillaume*

Inventor  
*James Young*  
*per Henry Orth*  
*att'y*

# UNITED STATES PATENT OFFICE.

JAMES YOUNG, OF KENTON, OHIO.

## IMPROVEMENT IN METALLIC FENCES.

Specification forming part of Letters Patent No. 206,384, dated July 23, 1878; application filed February 1, 1878.

To all whom it may concern:

Be it known that I, JAMES YOUNG, of Kenton, in the county of Hardin and State of Ohio, have invented certain new and useful Improvements in Metallic Fences, of which the following is a specification:

My invention relates to new and useful improvements in metallic fences; and consists in a peculiar construction of clamp for holding the pickets upon the cross-rails and preventing their displacement, and for adjusting said pickets when the fence is erected upon an inclined plane.

The invention further consists in the peculiar construction of a two-part clamp for locking the panels of fencing upon the posts, all as fully described hereinafter, and shown in the accompanying drawings, in which—

Figure 1 is a front elevation, and Fig. 2 a section on line *xx* of Fig. 1, of a metallic fence constructed according to my invention. Fig. 3 is a perspective view of the picket-clamp, and Figs. 4 and 5 are similar views of a two-part clamp adapted to lock the panels of the fence upon the respective posts.

In the drawings, A represents the iron posts, made of T-rails; B, the cross-rails, made of similar material; and C, the metallic picket, of any usual or preferred form. The picket is provided with one or more conical recesses, *c*, for the reception of the conical lugs or studs *d*, formed on the clamp D. This clamp is so constructed as to form a funnel-shaped or conical recess, *d'*, on its rear face, decreasing in width or diameter from the base toward the upper edge, where it is just large enough to permit the passage of the picket C, and has a conical lug or stud, *d*, formed on or near the upper edge, and in the center of the recess, as shown in Fig. 3, the lug on the clamp serving not only to hold the picket securely in its position upon the cross-rail and prevent any accidental displacement, but also as a pivot upon which the picket turns, or may be turned, to keep the same in a vertical position when the fence is erected upon an inclined plane, as will be readily understood, thus providing a means for adjusting the position of the pickets relatively to that of the cross-rails.

Each end or side of the clamps D is provided with a wedge-shaped projecting lip, *d<sup>2</sup>*, extending on one side from the center to the lower edge of the clamp, and tapering on its inner

face toward the extremity, and on the other side extending from the center to the upper edge, and having a similar taper, as shown at *d<sup>3</sup>* and *d<sup>4</sup>*, respectively, of Fig. 3.

By means of this construction the respective projections *d<sup>2</sup>* of opposite clamps are one above the other, and permit of the clamps being placed closer together, and form a solid bearing upon the face of the cross-rails B, upon which they are clamped by means of a clamp or clip, E, so constructed as to be slipped over said cross-rails and the lips *d<sup>2</sup>* of the clamps D, and hold the latter, together with the pickets, securely in position on the rails.

F G represent a clamping device made in two sections, and adapted to inclose the posts A and the ends of the cross-rails, to make the panels of the fencing fast upon said posts. The front section, F, has a vertical groove or recess, *f*, for the reception of the half of the face-plate *A<sup>1</sup>* of the post, and an angular plate, *f<sup>1</sup>*, which clasps the flange or plate *A<sup>2</sup>* of the post. The part *f<sup>x</sup>* of said angular plate *f<sup>1</sup>* projects slightly beyond the face of plate *A<sup>2</sup>*, and serves as an abutment for the plate *g<sup>1</sup>* of the section G.

Section F is further provided with a forward-projecting lip, *f<sup>2</sup>*, which clasps the clip E and holds it in position, and with lugs or ears *f<sup>3</sup>*, against which the projecting lips *g<sup>2</sup>* of section G abut.

The section G is provided with a T-groove, the vertical branch of which fits over the other half of plate *A<sup>1</sup>* of the post A, and the horizontal branch fits over the rear plate, *b*, of the cross-rail B. The outer edge of the horizontal groove is partially closed by a projecting lip or bridge-piece, *g*, which fits into a notch or recess, *b'*, formed in plate *b* of cross-rail B, (see detached view of same,) to lock the latter to the clamp-section G, the rear end of which, formed by plate *g<sup>1</sup>*, abuts against the part *f<sup>x</sup>* of section F, as above described.

Both the clamp-sections F G are provided with bolt-holes *h*, so located that when the bolt H is inserted it (the bolt) will be in frictional contact with the face-plate *A<sup>1</sup>* of the post A.

It will be seen by this construction of the two clamp-sections that both the post and cross-rail are practically inclosed within said sections, and the latter is securely held in position upon the post when the two sections are bolted together, thus preventing any displacement of the panels upon the posts A.

Under some circumstances I may form a semicircular groove or recess in the face-plate A<sup>3</sup> of the posts for the reception of one-half, more or less, of the bolt H to further secure the panel, though this is not necessary in metallic fences of the usual construction and weight, and would be of advantage only when an extra heavy fence is to be erected.

Having now described my invention, what I claim, and desire to secure by Letters Patent, is—

1. In a metallic fence, the combination, with the picket provided with one or more conical recesses and a cross-rail, of a clamp having a conical projecting lug or stud, substantially as described, for the purpose specified.

2. The clamp D, provided with a tapering recess, *d*<sup>1</sup>, substantially as shown, and for the purpose specified.

3. The clamp D, provided with a conical lug or projection, *d*, a tapering recess, *d*<sup>1</sup>, and the tapering ears or projections *d*<sup>2</sup>, all arranged and constructed substantially as described, for the purpose specified.

4. The combination of the T-shaped cross-rail B, the picket C, having conical recesses *c*, the clamp D, having a tapering recess, *d*<sup>1</sup>, on its rear face, and a conical projection, *d*, formed centrally at or near the upper edge of said re-

cess, and provided with lips *d*<sup>2</sup>, the upper edge of which inclines from the base toward the extremity, and said lips being located as described, and the clip E, all constructed, arranged, and operating substantially as and for the purposes specified.

5. In a metallic fence, the combination, with the T-shaped post A and T-shaped cross-rail B, of the two-part clamp F G, constructed to practically inclose said post and rail, and the bolt H, all constructed substantially as described, for the purpose specified.

6. The combination of the clip E and cross-rail B, the plate *b* of which is provided with a recess, *b*<sup>1</sup>, with the two-part clamp F G, the section G of which is provided with a horizontal groove and lug, *g*, and the lip or projection *f*<sup>2</sup> of the section F, the bolt H, and post A, all constructed, arranged, and operating substantially as described, for the purpose specified.

In witness that I claim the foregoing I have hereunto set my hand this 29th day of January, 1878.

JAMES YOUNG.

Witnesses:

JOHN HALEY,

JNO. C. McCOLLOUGH.