

R. J. BEATTY & L. ZIMMERMAN.
 Apparatus for Receiving Glass Casts from Molds.

No. 206,386.

Patented July 30, 1878.

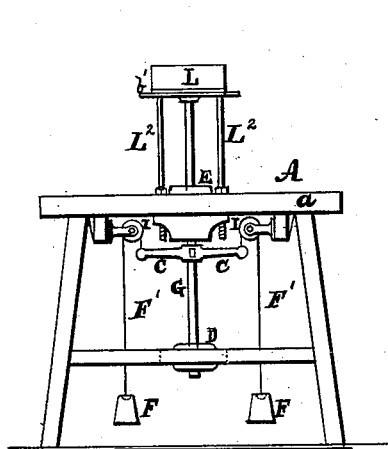

Fig. 1.

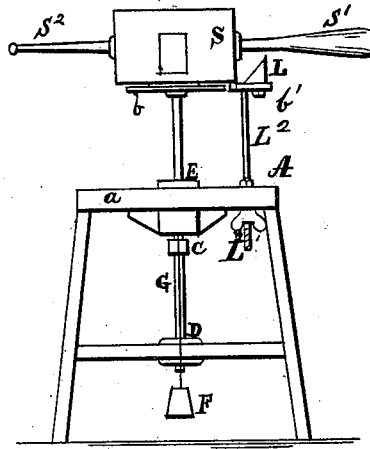

Fig. 2.

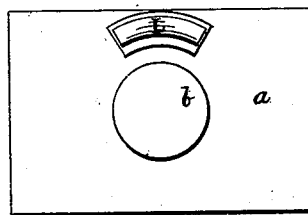

Fig. 3.

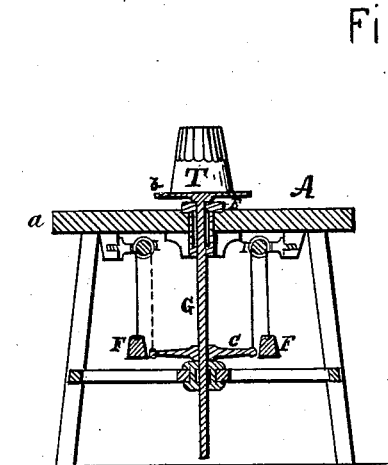

Fig. 4.

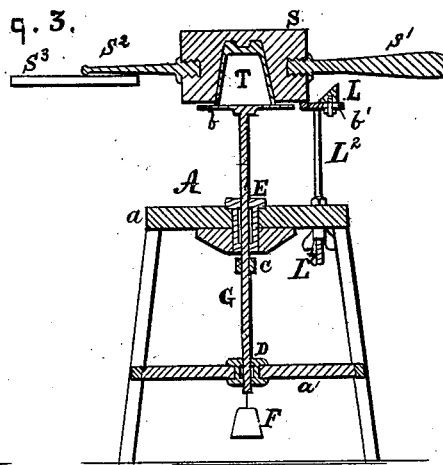

Fig. 5.

WITNESSES
R. H. Lacey
C. M. Sites

INVENTOR,
Robert J. Beatty
Lewis Zimmerman
 By *R. S. & A. P. Lacey*
attorneys

UNITED STATES PATENT OFFICE.

ROBERT J. BEATTY AND LEWIS ZIMMERMAN, OF STEUBENVILLE, OHIO.

IMPROVEMENT IN APPARATUS FOR RECEIVING GLASS CASTS FROM MOLDS.

Specification forming part of Letters Patent No. 206,386, dated July 30, 1878; application filed May 11, 1878.

To all whom it may concern:

Be it known that we, ROBERT J. BEATTY and LEWIS ZIMMERMAN, of Steubenville, in the county of Jefferson and State of Ohio, have invented certain new and useful Improvements in Apparatus for Receiving Glass Casts from Molds; and we do hereby declare that the following is a full, clear, and exact description thereof, which will enable others skilled in the art to which it pertains to make and use the same, reference being had to the accompanying drawing, and to the letters of reference marked thereon, which form a part of this specification.

Our invention relates to improvements in devices used in the manufacture of glass and other articles which are pressed or blown into form in molds, and require great care in their removal to prevent injury accruing either to the article itself or to the mold.

It has for its object to provide a machine which will carry the cast in a direct line away from the mold, so as to avoid all liability of the latter coming in contact with the former, and thus prevent injury to either.

It consists in a receiving table or platform arranged to descend in a vertical line, and so that, when the mold is placed over it for the purpose of removing the cast or molding, the latter will be received and carried away from and clear of the former, thus obviating the necessity of lifting or moving the mold.

It consists, further, in other mechanism, all of which will be hereinafter described.

In the drawings, Figures 1 and 2 show vertical elevations of our machine seen from different stand-points, and Fig. 3 is a plan view, and Figs. 4 and 5 are vertical sectional views on line at right angles to each other.

A is a substantial table or frame, to which the operating mechanism of our device is attached. E and D are bearings inserted in the top *a* and cross-bars *a'*, through which the vertical shaft G moves. *b* is the receiving-table, on which is deposited the cast T from the mold S. It is secured to the top of the shaft G, with which it moves up and down in the frame A.

c c are a series of arms, arranged opposite to each other and attached to the shaft G, with capability of adjustment to a higher or lower

position. I I are a series of pulleys attached under the top *a*, and arranged to receive the pulley-cords F', which have one end fastened to the arms *c* and the other to the counterbalancing-weights F.

The weights F slightly overbalance the weight of the shaft G and its attachments, so as to hold the latter elevated in the position shown in the drawings. When a weight, as the cast T, is placed on the platform *b*, the latter will be pressed down to the position shown in Fig. 4.

L² is a short vertical standard secured to the top *a* by the thumb-screw L³, by which it may be adjusted higher or lower, as required. *b'* is a platform or rest fastened on the top of the standard L², and serves as a support or rest for one side or edge of the mold S when the casting T is being deposited on the platform *b*.

On the outer side of the platform or rest *b* is secured a guide, L, which has its inner side beveled or inclined, so as to cause the mold S to pass to its proper position with its edge resting on the inner side of the platform L², and with the mouth of the mold centrally over the platform *b*. The rest or platform *b'* is always adjusted so as to have its top flush with the top of the platform *b*.

S is the mold, of ordinary construction, having the handle S¹ and tang S², adapted to be laid on the marver, which may be attached to the outer side of the frame A.

In the operation of the device, after the cast has been formed in the mold S, the latter is brought over the platform *b*, the tang S¹ resting on the bearing or standard L² and the handle S² resting in one hand of the operator. The cast or molding is held in place, if need be, by means of the cutting-off shears. When the mold is inverted the guide L will prevent the mold from being drawn too far off, and will also cause the mouth of the mold to instantly take position over the center of the platform. The edge of the mold is caught by the rest *b'*, by which and the marver S³, supporting the tang S², it is held steadily in position. The cast drops downward onto the platform *b*, which carries it in a vertical line downward from the mold, so that the edges or sides of the latter do not strike the cast.

It will be seen that the removal of the cast

from the mold by our invention prevents the frequent injuries caused by the two coming in contact when removed in the ordinary way.

We do not confine ourselves to the use of a central shaft or spindle.

It will be readily understood that the platform may be attached to two or more spindles, which descend through the table and have the cords attached to them by hooks or arms; or the platform may be supported between two or more standards erected above the top *a*, and have the pulleys in their upper ends with the cords extending upward through the table.

Our chief claim rests on the principle of removing the cast from the mold *a* by means of a platform or table arranged to receive and carry away the cast. The ordinary mode is to deposit the cast on a fixed table or platform, and then lift the mold off the cast.

Having described our invention, what we claim, and desire to secure by Letters Patent, is—

1. The vertically moving platform *b*, adapted to receive the cast and carry it down vertically out of and away from the mold, substantially as set forth.

2. The adjustable rest *b'* and guide *L*, in combination with the adjustable vertically-moving platform *b*, substantially as and for the purposes set forth.

3. The combination, with the frame *A*, having guides or bearings *D E*, and the platform *b*, having the vertical shaft *G* extending downward from its under side, of the adjustable arms *c*, pulleys *I*, and cords and weights *F' F*, substantially as set forth.

In testimony that we claim the foregoing as our own we affix our signatures in presence of two witnesses.

ROBERT J. BEATTY.
LEWIS ZIMMERMAN.

Witnesses:

M. BARBER,
GEORGE G. BRIGHT.