

G. A. HARVEY.
Corn-Harvester.

No. 206,395.

Patented July 30, 1878.

Fig. 1.

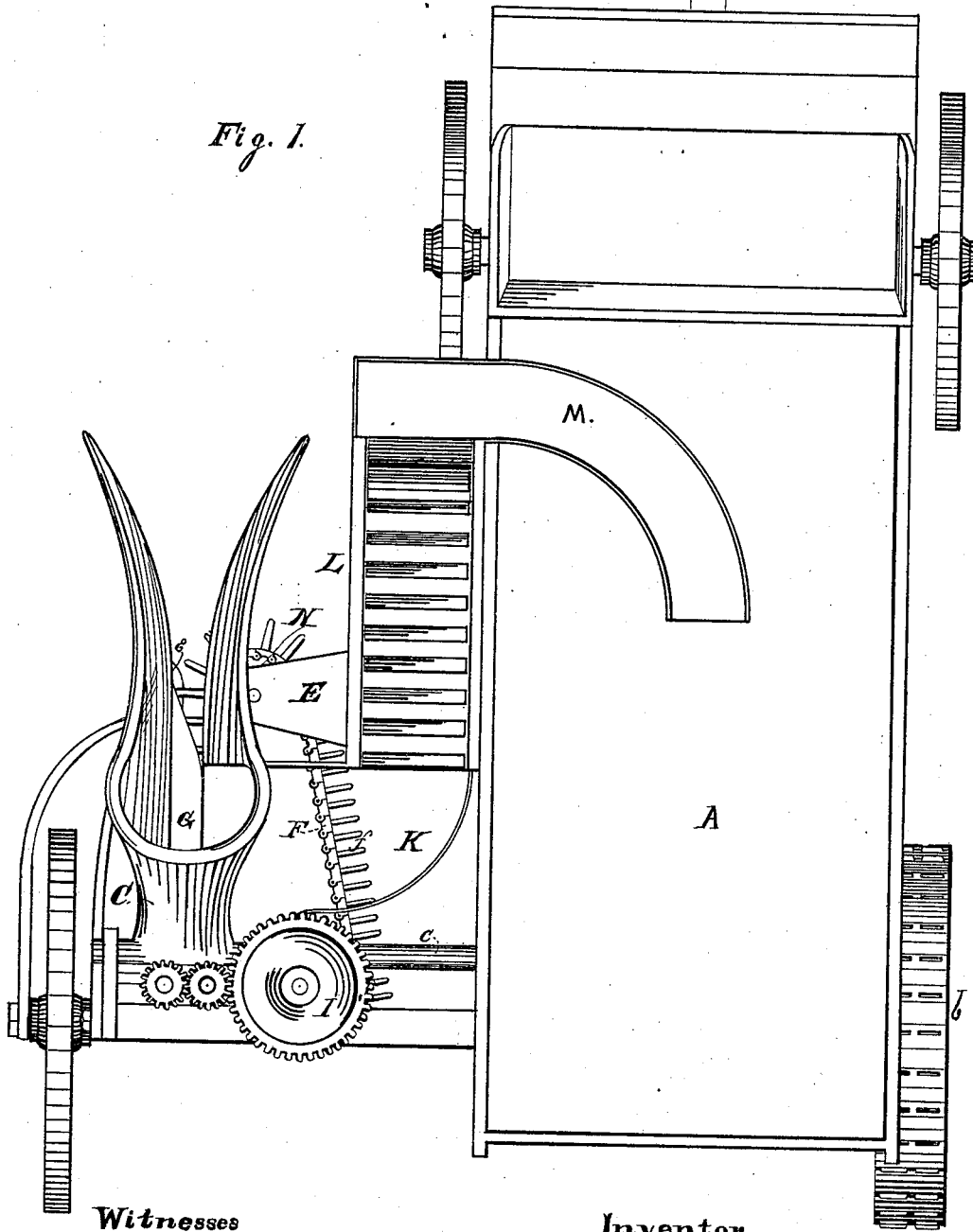

Witnesses

Inventor

H. G. Howe.

George A. Harvey.

Jno. C. Macgregor.

By *Colburn & Thacher*
Atty's

G. A. HARVEY.
Corn-Harvester.

No. 206,395.

Patented July 30, 1878.

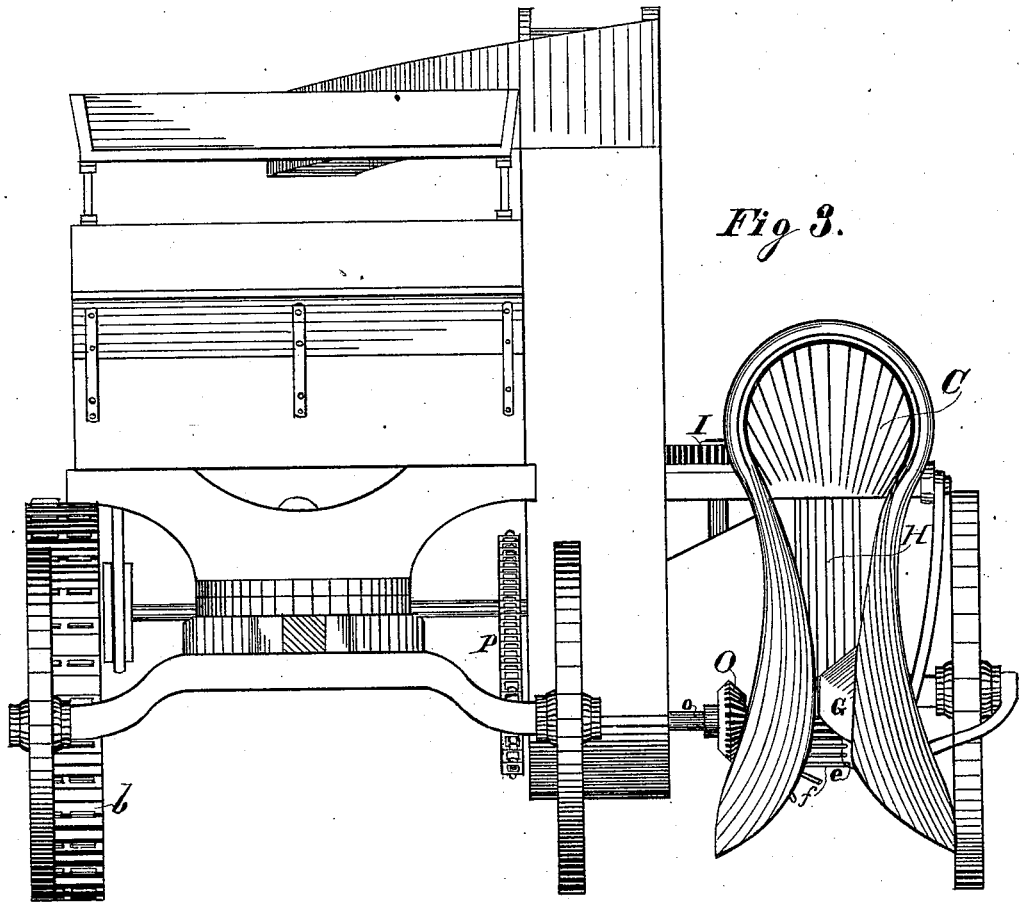

Witnesses.

H. G. Howe

Jno. Macgregor

Inventor

George A. Harvey

By *Colburn Thacher*
Atty's

G. A. HARVEY.
Corn-Harvester.

No. 206,395.

Patented July 30, 1878.

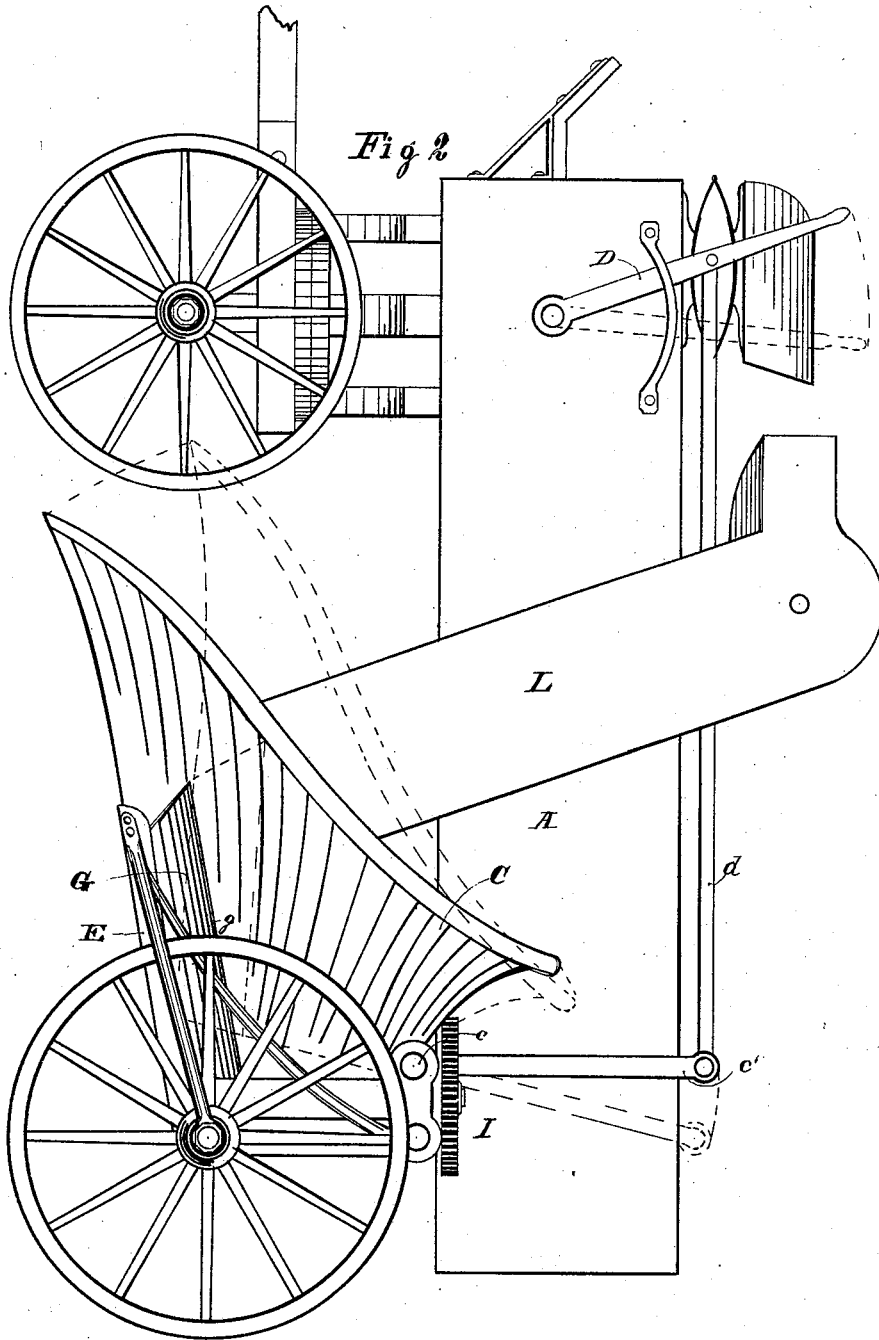

WITNESSES

A. G. Howe

Jno. Macgregor

INVENTOR

George A. Harvey

By [Signature] Atty's

G. A. HARVEY.
Corn-Harvester.

No. 206,395.

Patented July 30, 1878.

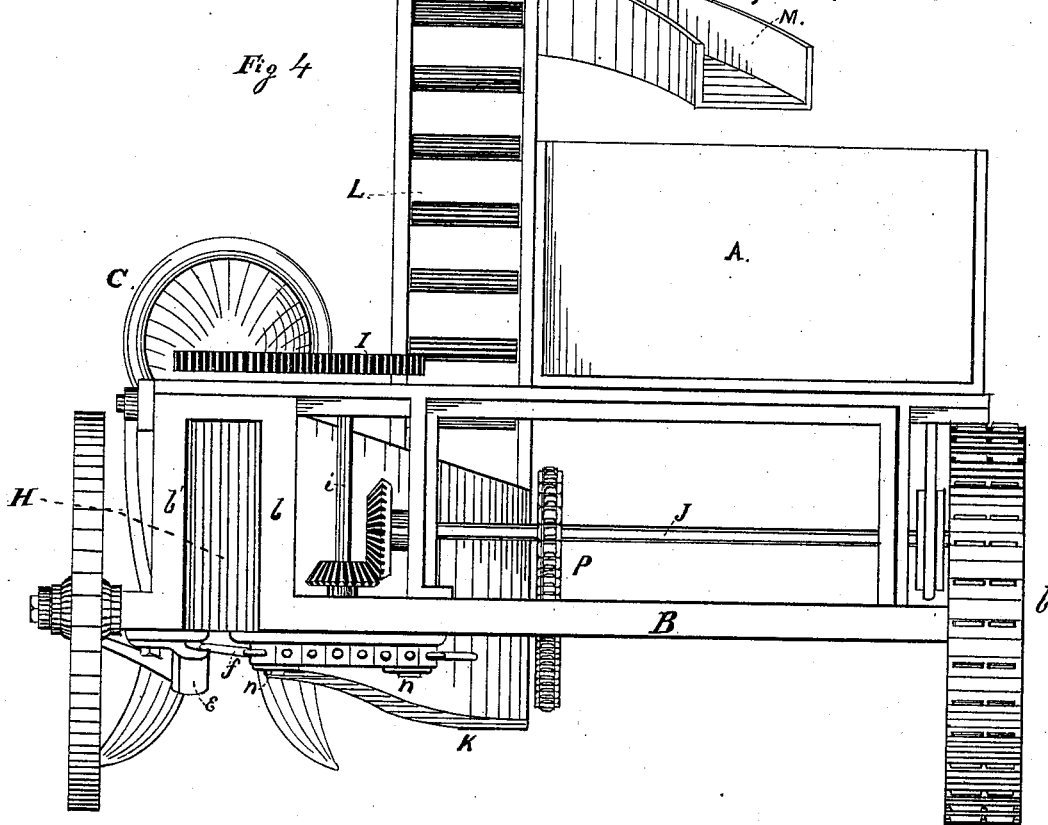

Fig 4

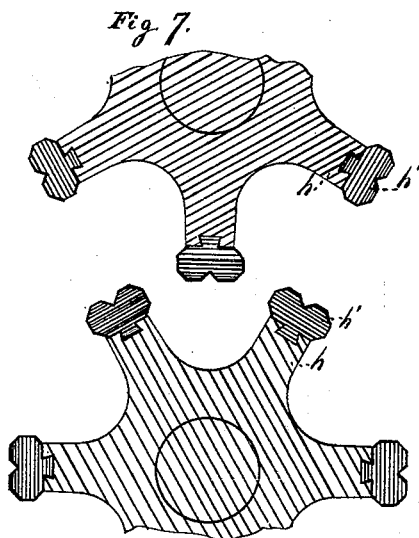

Fig 7.

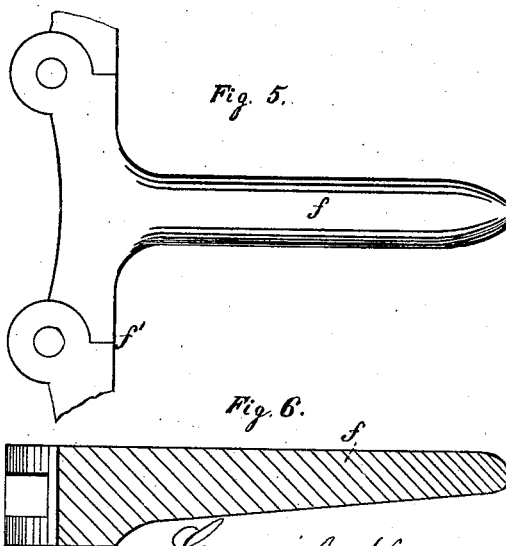

Fig. 5.

Fig. 6.

WITNESSES:
H. G. Howe
Jno. C. Macgregor

George A. Harvey,
INVENTOR:
By Coburn & Thacher Attys

UNITED STATES PATENT OFFICE.

GEORGE A. HARVEY, OF CHICAGO, ILLINOIS.

IMPROVEMENT IN CORN-HARVESTERS.

Specification forming part of Letters Patent No. **206,395**, dated July 30, 1878; application filed August 1, 1877.

To all whom it may concern:

Be it known that I, GEORGE A. HARVEY, of the city of Chicago, in the county of Cook and State of Illinois, have invented a new and useful Improvement in Corn-Harvesters, which is fully described in the following specification, reference being had to the accompanying drawings, in which—

Figure 1 represents a plan view of a corn-harvester containing my improvements; Fig. 2, a side elevation of the same; Fig. 3, a front elevation of the same; Fig. 4, a rear elevation of the same; Figs. 5 and 6, plan and sectional views, on an enlarged scale, of one tooth of the gathering-chain; and Fig. 7, a cross-section, on an enlarged scale, showing portions of the picking-rollers.

My invention relates to that class of corn-harvesters in which the ears are picked or broken from the stalks, and the latter are left standing in the field, while the ears are conveyed to a suitable wagon-box.

The invention consists in a stalk-gatherer of peculiar construction.

It also consists in the peculiar construction and arrangement of the picking-rollers.

It also consists in a spring-cover attached to the gatherer and projecting over the gathering-chain, but yielding to the pressure of the entering stalks.

It also consists in various devices and combinations of devices, all of which will be hereinafter more fully set forth.

In the drawings, A represents a wagon-body, which is mounted upon four wheels, but the rear axle, B, of which is extended considerably beyond the wagon-body at one side, and carries at the opposite end a driving-wheel, *b*.

The projecting end of the axle B has a long bend, *b'*, which projects upward, as shown in Fig. 4 of the drawings, and in front thereof is arranged a gathering-hood, C, the branches of which extend downward and outward, and are curved, as shown in the drawings. The gathering sides of this hood are deep, and the other upper or hood portion thereof is sufficiently high to permit the stalks to pass back underneath it by bending down their upper portions. The hood is attached to a rock-shaft, *c*, which is mounted in suitable bearings

on frame-work secured to the rear axle, and is connected to a hand-lever, D, at the forward end of the wagon by means of a rod, *d*, and arm *c'*, which is attached to the rock-shaft, so that by vibrating the lever the gathering-hood may be adjusted to raise and lower its forward end.

Below the outer branch of the gatherer an arm, E, extends forward from the rear axle, being slightly inclined downward, and constructed with an inwardly-projecting ledge or flange, *e*, at its lower edge, alongside of which a sprocket-chain, F, is arranged to run, the sections of which are provided with projections or teeth *f* long enough to project over the ledge *e* as they are carried backward, a narrow space being left between the chain and ledge.

A wing or cover, G, is hinged to the outer branch of the gathering-hood, so as to project over the gathering-chain, and is held up by a spring, *g*, which permits it to yield, however, to pressure of the stalks as it is brought against them.

In rear of the hood C, and partly within the bend in the axle, are two picking-rollers, H, arranged in a vertical position and mounted in suitable bearings on the frame-work of the machine. These rollers are fluted, as shown in the drawings, and are arranged so that the ribs on one shall but slightly enter the grooves in the other, thereby bringing the bite at the sides of the ribs and near their outer portions, instead of at the bottom of the grooves.

I prefer to construct these rollers as shown in Fig. 7 of the drawings, in which the outer edges of the ribs *h* are represented as faced with steel, *h'*, these facings being attached to the ribs by a dovetailed joint, and being constructed of polygonal contour. The upper ends of the shafts of these rollers are provided with pinions meshing with each other, and one of which meshes with a pinion, I, on a shaft, *i*, which is driven by the main drive-wheel through a horizontal shaft, J, and bevel-gear *j*, as shown in Fig. 4 of the drawings, and by means of which the rollers are caused to revolve inward—that is, toward each other. Upon the inside of the gatherer C, between it and the wagon-body, is an incline, K, which is arranged below the gathering and convey-

ing chain F. This incline or slide stands inward toward the wagon, and is depressed in the same direction, so that the gathering-chain upon its inside track will be a sufficient distance above the incline to permit ears of corn to pass freely underneath it. The relative position of these parts is clearly shown in Figs. 1 and 4 of the drawings.

An endless elevator-apron, L, is arranged at the side of the wagon, extending from the foot of the incline K to a little distance above the top of the wagon-body, and at its upper end is an inclined curved spout, M, which is arranged so that the elevator will discharge into it, and thence slide down into the wagon-body, over which the lower end of the spout extends.

The gathering-chain is constructed in a peculiar manner. The sections are made with square shoulders f' upon the outside, or the side to which the teeth are attached, as shown in Fig. 5 of the drawings. This construction permits the chain to be straightened out in a line, but prevents it from being bent beyond that line in an inward direction, so that as it is carried up on its outer course toward the picking-rollers it will be unyielding to pressure inward. This belt passes around three sprocket-wheels, one of which, N, is arranged just outside the lower end of the arm E, and the other two, $n n'$, at the rear of the machine, below the axle. The sprocket-wheel N is driven by bevel-gear O, mounted on a shaft, o , which, in turn, is rotated by means of a sprocket-wheel on its inner end, and a chain, P, passing around a sprocket-wheel on the shaft J, underneath the wagon-body, the shaft o being supported in suitable bearings at the foot and in front of the elevator L.

The operation of my improved machine is as follows: The machine is drawn along over the field, outside of the standing row, so as to bring the gatherer in line with the latter, and the stalks enter between the lower flaring ends of the gatherer, which should be depressed so as to take the stalks below the ears thereon, and pick up any of the ears which have lopped over. As the machine progresses the teeth on the gathering-chain soon take the stalks between the two branches of the gatherer, and hold them securely until taken by the picking-rollers H, by which they are seized and drawn through until the ears are reached, which are broken off in the usual way, and fall down upon the incline K, to which they are directed by the spring guard or cover g , which prevents their falling upon the chain. The stalks are delivered from the rollers of the machine still standing in the field, while the picked ears slide down the incline K, underneath the gathering-chain, to the foot of the elevator L, by which they are taken up and delivered into the spout M, whence they are discharged

into the wagon-body. The peculiar curved form of the gathering-arms, which are bent inward and upward, as shown in the drawings, permits the stalks of corn to be picked up without much danger of breaking, as the straightening up of the stalks is accomplished gradually and without any sudden and angular bends. The elevator is driven by the shaft o , which also drives the gathering-chain.

If the teeth on the gathering-chain are arranged sufficiently near together, the cover g may possibly be dispensed with, for the teeth will cover the open space, so that no corn can fall through, and the ears will be tipped over into the chute K.

On account of the peculiar construction and arrangement of the rollers the stalks will pass through them more readily than when the grooves are more nearly filled by the ribs or flanges, and the bend in the axle provides a free space through which the stalks escape at the rear of the machine. The upright or vertical position of the rollers prevents the bending over of the stalks which occurs when the rollers are placed in an inclined position, as the stalks are not affected by the rollers until they come immediately before them, and are then passed through in a moment.

Having thus described my invention, what I claim, and wish to secure by Letters Patent, is—

1. The gathering-hood C, constructed of the form and with the curves substantially as and for the purpose set forth.

2. The guide-arm E, provided with the ledge e , in combination with the gathering-chain F, having teeth f , arranged and operating substantially as and for the purpose set forth.

3. The gathering-hood C, in combination with the flanged arm E and toothed chain F, arranged and operating substantially as and for the purpose set forth.

4. The elastic guard or cover G, hinged to the gatherer, and held in position by a spring, substantially as and for the purpose set forth.

5. The rollers H, constructed with longitudinal grooves, and arranged with ribs slightly intermeshing, so that the bite is at their outer edges only, substantially as and for the purpose set forth.

6. The steel facing-strips h' , attached to the outer edges of the flanges or ribs h of the picking-rollers H, substantially as and for the purpose set forth.

7. The axle B, bent vertically, as described, in combination with a pair of picking-rollers, H, arranged just in front of or just in the bend of the axle, substantially as and for the purpose set forth.

GEORGE A. HARVEY.

Witnesses:

JNO. C. MACGREGOR,
W. C. CORLIES.