

C. M. MILLER.
Slide-Valve for Steam-Engines.

No. 206,398.

Patented July 30, 1878.

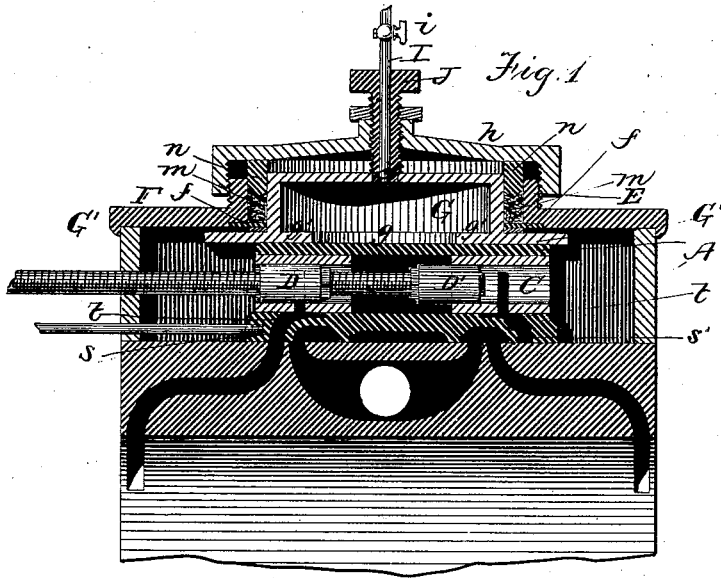
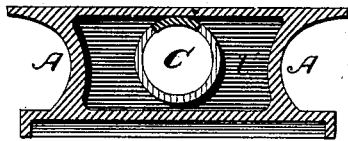

Fig. 2.



Witnesses:
John V B. Towers
Chas. R. Burr

Inventor
Cassius M. Miller
By *Leopold Hill*
Hrs atty

UNITED STATES PATENT OFFICE.

CASSIUS M. MILLER, OF CANTON, OHIO, ASSIGNOR OF ONE-HALF HIS RIGHT
TO C. AULTMAN & CO., OF SAME PLACE.

IMPROVEMENT IN SLIDE-VALVES FOR STEAM-ENGINES.

Specification forming part of Letters Patent No. **206,398**, dated July 30, 1878; application filed
May 20, 1878.

To all whom it may concern:

Be it known that I, CASSIUS M. MILLER, of Canton, in the county of Stark and State of Ohio, have invented certain new and useful Improvements in Slide-Valves for Steam-Engines; and I do hereby declare the following to be a full and exact description of the same, reference being had to the accompanying drawings, forming part of this specification, in which—

Figure 1 is a longitudinal vertical section of my invention, and Fig. 2 a transverse section of the slide-valve detached.

Similar letters of reference in the several figures denote the same parts.

My invention relates to that class of valves in which a variable cut-off is effected by means of a slide valve or valves working within the body of the main valve; and it consists in making the internal cut-off valve or valves to fit closely, like pistons, in the passage in which they slide, and in extending the steam-ports nearly or quite around such passage, so that they can be made very narrow, and the valves caused to cut off the steam almost instantaneously.

It also consists in certain minor details of construction, which will be hereinafter more fully described.

In the drawings, A represents a common double slide-valve, having steam-ports S S', and operating in connection with the ordinary valve-seat, having the usual steam and exhaust passages. Through the back of the valve, longitudinally, and parallel to its face, is provided a straight passage, C, preferably cylindrical in shape, through which the live steam enters the ports S and S' alternately, and passes to the steam-cylinder. The cut-off valves D D' are arranged within the passage C in the usual manner, except that they are made in the form of pistons, fitting the passage C closely at their sides and top, as well as on their under surface. The steam-ports S S' are extended nearly or quite around the cylindrical passage C, so as to take steam on all sides thereof, whereby their mouths may be made in the form of a narrow slit, which will be almost instantaneously opened or closed by the movement of the cut-off valves. Back

of their mouths, within the body of the valve, these ports or steam-passages are enlarged or chambered out, as shown at *t*, to give a freer movement to the steam. The cut-off valves are adjusted and operated in the usual manner.

It will be seen that by this construction the cut-off valves will not only operate more quickly and effectually, but will themselves be more completely balanced than as heretofore constructed. At the back or upper side of the valve a large opening, E, is made in the cover of the steam-chest F, and a sliding hollow cylinder, G, is closely fitted therein, having a flat plate, G', at its lower end, which rests lightly upon and is closely fitted to the back of the valve. The plate G' is provided with a large central opening, *g*, and with projecting corners or edges *g' g'*, which latter serve, by the pressure of the surrounding steam, to hold the plate in contact with the valve and the valve properly to its seat. The upper end of the hollow cylinder G fits into a collar, *f*, upon the steam-chest cover, and is provided with a packing, *m*, secured and adjusted by a gland, *n*, by means of a screw-cap, *h*, as will be readily understood.

A small air-pipe, I, provided with a cock, *i*, serves to place the interior of the cylinder G in communication with the open air at the will of the engineer. This air-pipe may be arranged within a hollow set-screw, J, provided for the purpose of enabling the engineer to set the plate G' against the back of the valve whenever it may for any purpose be desirable to do so.

It will be seen that by this construction the cylinder G and its plate G' completely exclude the steam from a large area on the back of the valve, which area can at will be put in direct communication with the open air, thus completely relieving the valve of a large portion of the steam-pressure, and yet retaining on the projecting parts of the plate around the hollow center a sufficient steam-pressure to hold the plate in close contact with the valve, and the valve at all times properly to its work.

The surfaces in sliding contact are all to be made as smooth and closely fitting as possi-

ble, in order to diminish friction and wear and secure steam-tight connections.

The lower edge of the gland *n* is to be made V-shaped, as shown, in order that it may expand the soft hemp packing *m* into close and constant contact with the proximate surfaces, and thus insure a perfectly steam-tight joint.

Having thus described my invention, I claim as new—

1. The main slide-valve, having ports S S' and a substantially-cylindrical passage, C, in combination with piston cut-off valves D D, closely fitting the cylindrical passage, substantially as described.

2. The main slide-valve, having the substantially-cylindrical passage C, and having ports S S', the mouths of which extend in a narrow slit nearly or quite around the walls

of the passage C, substantially as described, for the purposes specified.

3. The main slide-valve, having the substantially-cylindrical passage C, and having the ports S S', with narrow mouths extending substantially around the passage C, in combination with the enlarged or chambered steam-passages *t* back of said mouths, substantially as described.

4. The sliding cylinder G, screw-cap H, and collar *f*, in combination with the gland *n*, having a V-shaped lower edge, and with the packing arranged in the space between the ports G *f* *n*, substantially as described.

CASSIUS-M. MILLER.

Witnesses:

JNO. M. WELLS,
ORLANDO RANK.