

F. FAIRBANKS.
Platform-Scale.

No. 206,428.

Patented July 30, 1878.

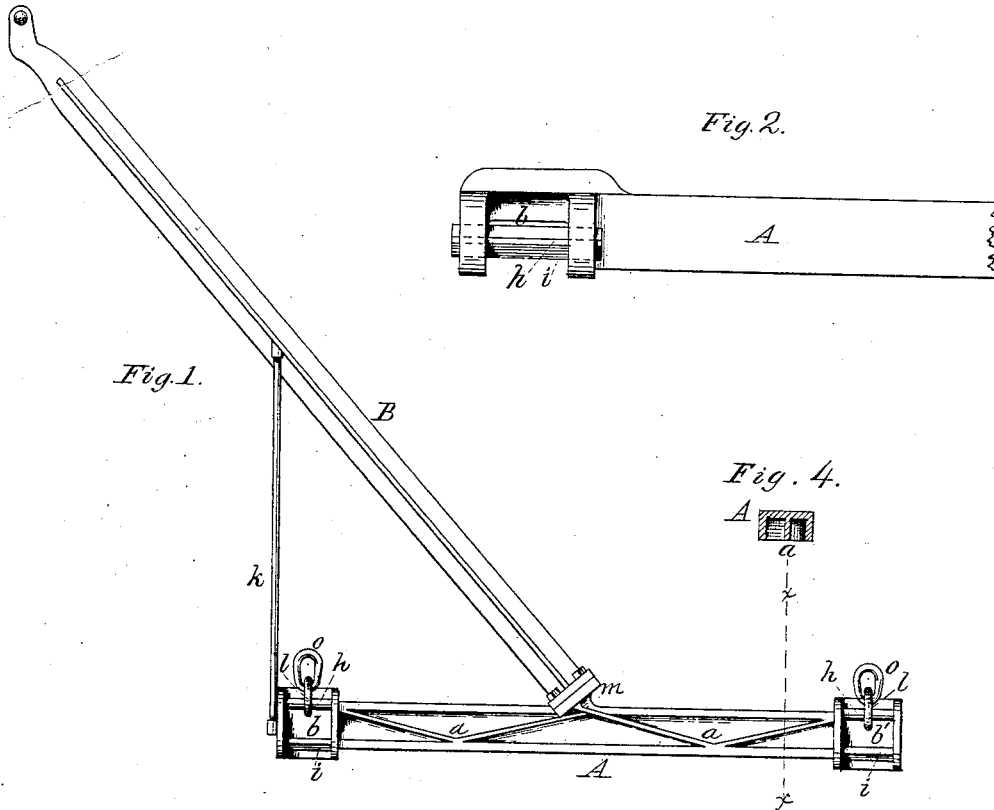

Fig. 3.

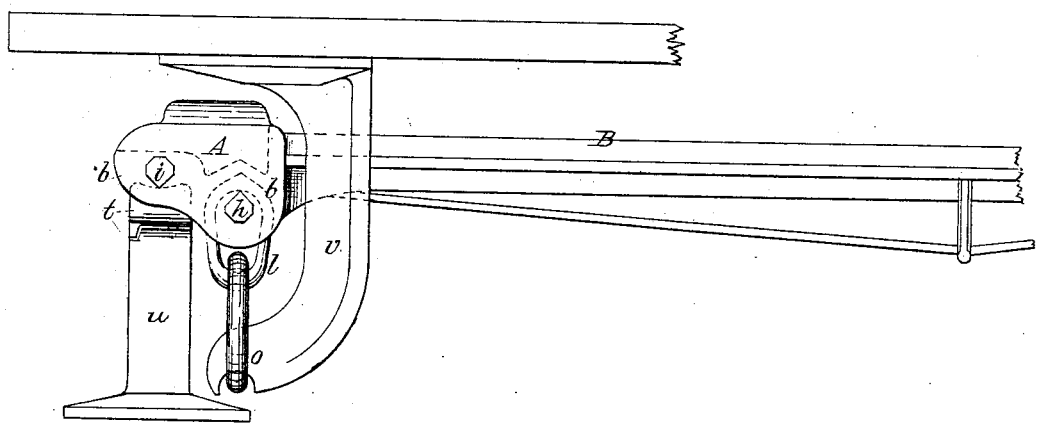
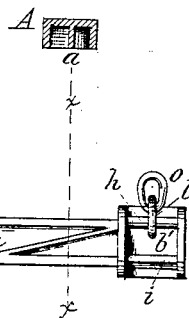

Fig. 4.



Attest:
Chas. M. Higgins,
Edmund H. Wales.

Inventor:
Franklin Fairbanks
by his Attorneys:
J. H. Wales & Son

UNITED STATES PATENT OFFICE.

FRANKLIN FAIRBANKS, OF ST. JOHNSBURY, VERMONT.

IMPROVEMENT IN PLATFORM-SCALES.

Specification forming part of Letters Patent No. **206,428**, dated July 30, 1878; application filed May 28, 1878.

To all whom it may concern:

Be it known that I, FRANKLIN FAIRBANKS, of St. Johnsbury, Caledonia county, Vermont, have invented certain new and useful Improvements in Hay or Platform Scales, of which the following is a specification:

The present improvement lies in the construction of the large levers on which the platform rests, and is designed more particularly for large platform-scales, such as used for weighing hay, coal, stock, &c.

In platform-scales, as scale-makers understand, the platform is suspended on two levers, one at each end, which convey the weight to the steelyard or beam. These levers usually proximate in form to an **L**, one member of which is fulcrumed longitudinally, forming the short arm of the lever, and acting as a rocking shaft or bar, while the long arm of the lever extends therefrom at nearly a right angle, or slightly oblique, and its extremity is received in the stirrup of the steelyard-rod, which conveys the strain to the graduated beam of the scale. An intense twisting or torsional strain is thus brought to bear on the rocking fulcrum-bar of the lever, which consequently requires great torsional stiffness. This part of the lever has been usually cast tubular; but it has been found that this form, though favorable to strength, requires too much metal to give the requisite stiffness; and, moreover, there is great liability of the core becoming displaced in the mold, which results in an imperfect casting, liable to spring under the strain, and which, of course, seriously impairs its value for the purposes of a scale.

The object of my invention is therefore to so construct the lever as to obtain the greatest torsional stiffness in the rocking fulcrum-bar of the lever with the least metal, and to so dispose the metal in its structure as to uniformly distribute and equalize the strain thereon, and also to more effectually protect the pivots or knife-edges of the lever from exposure to the weather, and to arrange them in a position more favorable to strength.

To avoid unnecessary repetitions, the invention will be fully set forth in the description, and its definite features of novelty specifically indicated in the concluding claims.

In the drawings, Figure 1 is an inverted plan of my improved platform-lever, showing its under side, and representing the main features of construction. Fig. 2 is a side elevation, giving an end view of the rocking fulcrum-bar of the lever, which is shown mounted in the position which I prefer to employ—that is, the lever is fulcrumed on a rocking fulcrum-block, *t*, capable of a slight rocking movement on the top of the supporting-stand *u*, while the platform-bearing *v* is hung from the short arm by two links, *l o*, placed relatively at right angles. This arrangement of rocking fulcrum-block and double connecting-links gives the parts, as will be seen, a greater freedom and ease of motion, and enables the parts to adapt themselves to any changes in the foundation or general frame-work of the scale without injuring the integrity of the scale. Fig. 3 is a fragmentary longitudinal view of the end of the fulcrum-bar, showing the situation of the pivots. Fig. 4 is a transverse section of the bar on line *x x* of Fig. 1.

In the drawings, **A** represents the rocking fulcrum-bar of the lever, and **B** is the long arm, which is usually formed separately from the rocking bar and bolted thereto by a flanged coupling, as shown at *m*. The novelty of construction lies mainly in the fulcrum-bar **A**, and consists chiefly in constructing it in the form of a three-sided elongated box or double-flanged girder, with internal zigzag braces *a a* running from side to side, as seen in Figs. 1 and 4, and which is cast in one piece in the form described. This plan of construction imparts great torsional and transverse stiffness to the rocking bar with the least amount of metal, and will give a perfect casting without any appreciable springing or warping, which are advantages of prime importance for the purposes of a scale.

Another feature of the lever is that the pivots or knife-edges *h i* are arranged directly on the ends of the lever in an incased or covered socket or cavity, *b b'*, as shown in the drawings, which protect the pivots from the effects of the weather, preventing the accumulation of wet or ice to clog the action of the pivots, as often occurs with the usual exposed arrangement.

It will also be noted that the pivots are

arranged equidistant on each side of the longitudinal center-line of the bar, and in almost a line with the flanged sides of the bar. This is an important feature of the construction, as it brings the torsional strain centrally and uniformly on the bar, and uniformly distributes it thereon. Heretofore the pivots have been usually arranged wholly to one side of the bar, and in an uncovered or exposed situation.

A still further feature of the lever consists in extending the long arm B from the center of the rocking bar A, as shown in Fig. 1, and in disposing the zigzag braces *a a* in an apex at the point of connection of the long arm, as represented. The long arm of the lever has been usually extended slightly oblique from one end of the fulcrumed bar; and the advantage of extending it obliquely from the center of the fulcrumed bar, as in my improved lever, is that the strain is thus brought centrally on the bar and uniformly distributed along each end thereof, thus imparting greater strength to the lever with less material, while the advantage of having the zigzag braces *a a* meet in an apex at the point of connection of the long arm is that this arrangement is found to impart much greater torsional and transverse stiffness to the fulcrumed bar than any other disposition of the material.

As seen in Fig. 1, a stay-rod, *k*, preferably made of wrought pipe, extends at a right angle from the end of the fulcrumed bar A and joins the oblique long arm B, to brace and steady the same, and the under side of the long arm is preferably trussed, as usual.

This general construction of the platform-lever is a result of practical experiments, and

embodies a combination of important qualities for the special purpose of a scale-lever.

What I claim as my invention is—

1. A scale-platform lever having its fulcrumed arm formed in the shape of a three-sided elongated box, with internal zigzag braces, substantially as herein shown and described.

2. A platform-scale lever having its fulcrumed arm formed in the shape of a three-sided elongated box, with internal zigzag braces, and having its long arm B attached to the fulcrumed arm A at a point where the zigzag braces *a a* meet in an apex, substantially as and for the purpose set forth.

3. A platform-scale lever having its fulcrum-arm A arranged parallel with the fulcrum-line, and having its long arm B extended obliquely from the center of its fulcrumed arm A, substantially as herein shown and described.

4. A scale-platform lever having its fulcrumed arm A arranged parallel with the pivot or fulcrum line, and having its pivots arranged directly on the ends of the said fulcrumed arm A and equidistant on each side of its longitudinal center-line, substantially as and for the purpose set forth.

5. A scale-platform lever having the ends of its fulcrumed bar provided with covered or inclosed cavities or sockets *b b'*, in which its pivots are arranged and protected, substantially as herein shown and described.

FRANKLIN FAIRBANKS.

Witnesses:

WM. S. WELLS,

EDWARD H. WALES.