

E. P. FOLLETT.
Lamp-Burner.

No. 206,432.

Patented July 30, 1878.

Fig: 1.

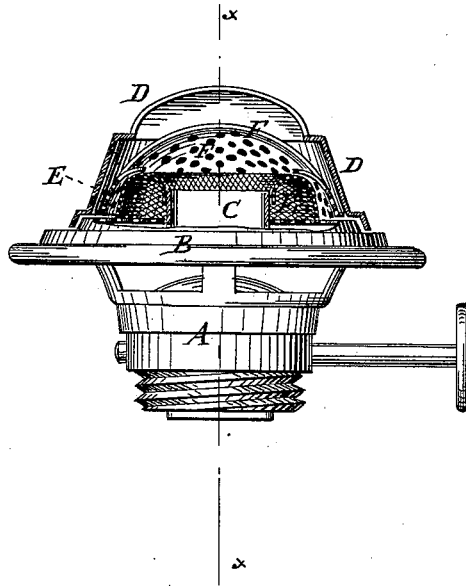
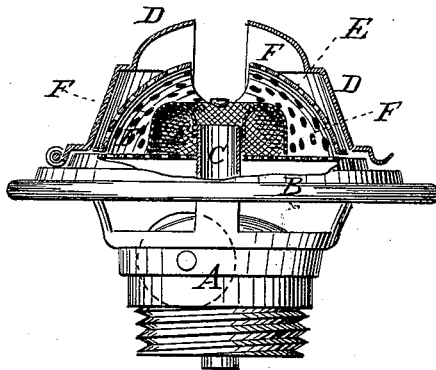

Fig: 2.



WITNESSES:

Cras. Nida.
C. Sedgwick

INVENTOR:

E. P. Follett
BY *Munn Co*

ATTORNEYS.

UNITED STATES PATENT OFFICE.

EDWARD P. FOLLETT, OF ROCHESTER, NEW YORK.

IMPROVEMENT IN LAMP-BURNERS.

Specification forming part of Letters Patent No. **206,432**, dated July 30, 1878; application filed June 28, 1878.

To all whom it may concern:

Be it known that I, EDWARD P. FOLLETT, of Rochester, in the county of Monroe and State of New York, have invented a new and Improved Lamp-Burner, of which the following is a specification:

Figure 1 is a vertical section of my improved lamp-burner. Fig. 2 is a vertical section of the same, taken through the line *x x*, Fig. 1.

Similar letters of reference indicate corresponding parts.

The object of this invention is to furnish an improved attachment for the burners of lamps, kerosene-stoves, &c., the use of which will cause a more thorough combustion of the oil, and will produce a steadier, whiter, and larger flame than is possible with ordinary burners of the same size.

The invention consists in the combination of the wire-gauze shield, constructed as hereinafter described, with the perforated plate, the wick-tube, and the cone of a lamp-burner; and in the combination of the perforated sheet-metal cap, constructed as hereinafter described, with the wire-gauze shield, and with the perforated plate, the wick-tube, and the cone of a lamp-burner, as hereinafter set forth.

A represents the base or collar, B the perforated plate, C the wick-tube, and D the cone, of a lamp-burner, about the construction of which parts there is nothing new. E represents a shield, made of fine wire-gauze, having a hole cut through its center of such a shape and size as to receive the wick-tube C.

The inner edge of the gauze is then curved downward to rest against the outside of the wick-tube, and its outer edge is curved downward and trimmed off, so as to rest upon the plate B. The curved or arched upper part of the shield E rises above the top of the wick-tube C all around, as shown in Figs. 1 and 2.

In making the shields E, they are struck up into the required shape with dies. By this construction the air that rises to the flame

around the wick-tube C is minutely divided, and is projected in a multitude of fine streams against the flame. At the same time the shield becomes heated, so as to heat the air before it strikes the flame. The effect of this is to produce a larger, whiter, and steadier flame than is possible with ordinary burners of the same size.

F is a cap of finely-perforated sheet metal, which is struck up with dies into the form of a section of a sphere, and which has a slot formed through its top of about the shape and size of the slot through the cone D. The base of the cap F is made of such a size as to inclose all the perforations through the plate B. In using the burner with this cap F, the said cap F becomes heated, and heats the air as it rises around the shield E to the flame, and thus increases the effect of the said shield E.

By extending the wick-tube C and the cone D upward, and extending the outer wall of the shield E downward, so that it may still rest upon the plate B, the burner may be used without a chimney. In this case the lower part of the shield E may be made of sheet metal, if desired.

Having thus fully described my invention, I claim as new and desire to secure by Letters Patent—

1. The combination of the wire-gauze shield E, constructed as described, with the perforated plate B, the wick-tube C, and the cone D of a lamp-burner, substantially as herein shown and described.

2. The combination of the perforated sheet-metal cap F, constructed as described, with the wire-gauze shield E, and with the perforated plate B, the wick-tube C, and the cone D of a lamp-burner, substantially as herein shown and described.

EDWARD P. FOLLETT.

Witnesses:

JAMES T. GRAHAM,
C. SEDGWICK.