

W. H. BRAMBLE.

Padlock.

No. 206,528.

Patented July 30, 1878.

Fig. 1.

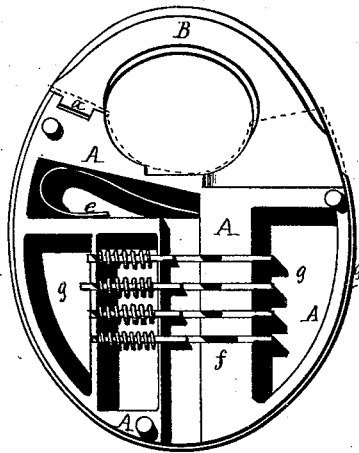

Fig. 2.

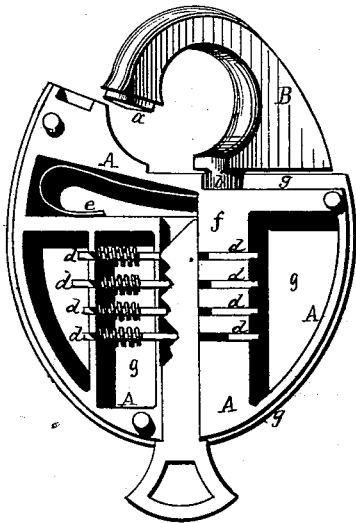

Fig. 3.

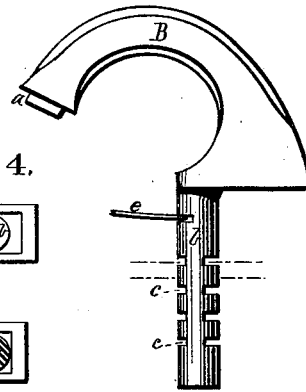

Fig. 4.

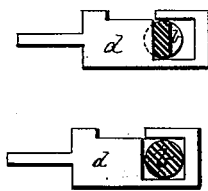

Fig. 5.

WITNESSES.

*H. Hardy*  
*P. B. Sparks*

INVENTOR.

*William H. Bramble*

# UNITED STATES PATENT OFFICE.

WILLIAM H. BRAMBLE, OF DECATUR, ILLINOIS.

## IMPROVEMENT IN PADLOCKS.

Specification forming part of Letters Patent No. **206,528**, dated July 30, 1878; application filed December 14, 1877.

*To all whom it may concern:*

Be it known that I, WILLIAM H. BRAMBLE, of Decatur, in the county of Macon and State of Illinois, have invented certain new and useful Improvements in Padlocks; and I do hereby declare that the following specification, taken in connection with the drawings furnished and forming a part of the same, is a clear, true, and complete description thereof.

One portion of my improvement relates to the construction of the case, and its object is economy in manufacture and security of the interior mechanism; and to these ends my invention consists in a padlock-case which has one side and its rim cast in one piece, provided with a solid housing for the shank of the shackle and solid webs or partitions, which afford bearings for the tumblers and their springs, the several webs, partitions, and the housing occupying the interior space between the back and front of the lock, and affording a strengthening-support for the front plate. This solid side and rim is directly connected with a swinging shackle.

Another portion of my improvement relates to the locking mechanism in spindle-shackle padlocks. I attain thereby a more than ordinary degree of security against picking at very light cost in construction and fitting; and my invention further consists in a padlock embodying a shackle having a spindle, which is provided with oppositely-located gatings and is housed in the body of the lock, in combination with sliding spring-tumblers, which inclose the spindle and move in slots transverse to the axis of the spindle, and engage with its gatings.

To more particularly describe my invention I will refer to the accompanying drawings, in which—

Figure 1 represents one of my padlocks with the side plate removed and shackle closed. Fig. 2 represents the same with shackle open. Fig. 3 represents the shackle detached. Figs. 4 and 5 are side views of tumblers with the shackle-spindle in section.

A denotes the body of the lock, which includes the rear side, the rim, and the interior partitions, cast in one piece. The several partitions extend inwardly from the rim, and in some cases from rim to rim, and merge there-

with; and although these are subsequently fitted to receive the moving parts of the lock, they operate as interior braces for the rim, and also as interior supports for the side of the lock which is riveted to the solid portion, and I am enabled thereby to produce at low cost a cast-iron lock-case of great strength.

B denotes the shackle. At its front end, *a*, it is provided with a tenon, which occupies, when locked, a corresponding mortise or socket in the lock-body, as clearly shown. The spindle *b* is located in the center of the base of the shackle or at the outer end, as heretofore, so that the spindle will not be liable to be unduly strained or injured from a blow on either the front or rear of the shackle. The spindle is provided with lateral notches or gatings *c*, into which the tumblers *d* enter when locked. The opposite notches receive the opposite sides of the tumblers when unduly moved, as in "picking." The shackle is provided also with a spring, *e*, the tendency of which is to force the spindle inward. It also prevents the shackle from being pulled unduly outward when unlocked.

The tumblers *d* have shanks, which are inclosed by spiral springs, and they occupy transverse slots cut in the casting. The spindle *b* of the shackle is housed in the nearly-central portion *f* of the casting, and its gatings are coincident with the tumbler-slots. The solid housing for the spindle occupies the space between the back and front of the lock. Each tumbler has a square opening, as seen in Figs. 4 and 5, occupied by the spindle. When locked each tumbler is entered at one side of its square opening into its respective gating or notch in the spindle, as in Fig. 4, and when unlocked by the key, as in Fig. 2, the tumblers are wholly free from the spindle, as in Fig. 5, so that the latter may be drawn upward sufficiently to allow the tenon on the front end of the shackle to leave its mortise. The side of the lock *g* which is cast solidly with the rim and interior partitions is extended upward at the base of the shackle sufficiently to slightly overlap upon the side of the shackle, and affords a support against lateral displacement.

The detachable side plate is not shown in the drawing; but it has an outline generally corresponding with the body of the lock, with

its upper portion extended so as to largely overlap the hasp at its base, and also at its front end, as indicated by dotted lines in Fig. 1.

The gated spindle and the tumblers shown are of simple and comparatively inexpensive construction; but such a lock affords greater security than many which are far more intricate and costly.

Having thus described my invention, I claim as new and desire to secure by Letters Patent—

1. A padlock having one side of its case and its rim cast in one piece, and provided with a solid housing for the shackle-spindle and solid

webs or partitions, which afford bearings for the tumblers and springs, and which occupy the space between the back and the front plate and serve as interior abutments for the front plate, as set forth.

2. The combination, in a padlock, of a hasp having a spindle provided with lateral gatings and a series of sliding spring-tumblers, which surround the spindle and engage with the gatings therein, substantially as described.

WILLIAM H. BRAMBLE.

Witnesses:

J. A. BROCKWAY,  
E. F. EWING.