

J. M. KEEP.
Cigar-Lighter.

No. 206,577.

Patented July 30, 1878.

Fig. 1.

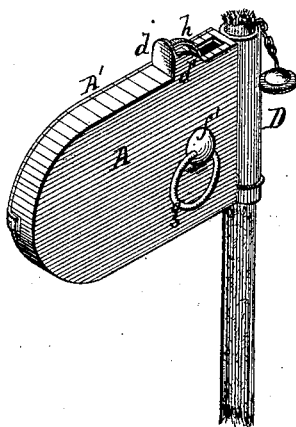

Fig. 5.

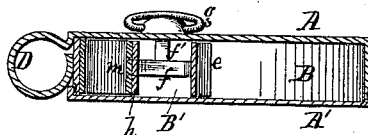

Fig. 2.

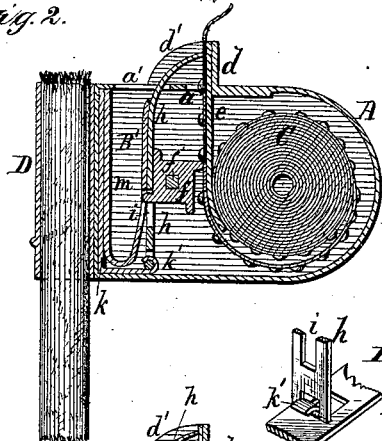

Fig. 4.

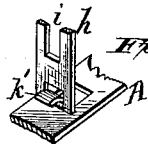
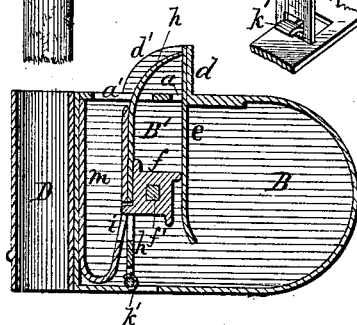

Fig. 3.



Witnesses.
Frank L. Curaud
Aley Mahon

Inventor.
James M. Keep
by A. M. Smith
Attorney.

UNITED STATES PATENT OFFICE.

JAMES M. KEEP, OF JERSEY CITY, NEW JERSEY, ASSIGNOR TO GEORGE SELDEN, OF ERIE, PENNSYLVANIA.

IMPROVEMENT IN CIGAR-LIGHTERS.

Specification forming part of Letters Patent No. 206,577, dated July 30, 1878; application filed February 12, 1878.

To all whom it may concern:

Be it known that I, JAMES M. KEEP, of Jersey City, county of Hudson, State of New Jersey, have invented certain new and useful Improvements in Cigar-Lighters, of which the following is a full, clear, and exact description, reference being had to the accompanying drawings, making part of this specification, in which—

Figure 1 represents a perspective view of my improved lighter. Fig. 2 is a side elevation, partly in section, with the side plate or cover removed, showing the internal arrangement of parts. Fig. 3 is a similar view, showing a slight modification in the construction and arrangement of parts, with the percussion-tape removed. Fig. 4 is a detached view, showing the manner of hinging the hammer to the casing embraced in the modification shown in Fig. 3; and Fig. 5 represents a horizontal section through Fig. 3.

Similar letters of reference denote corresponding parts wherever used.

The invention relates to a novel arrangement of the hammer and its actuating-spring in connection with each other and the inclosing-case, whereby they are made separate and removable; and to the arrangement of a pendent yielding apron in connection with the hammer and its actuating mechanism, as hereinafter described.

In the accompanying drawings, A represents the box or case of the lighter, and A' the side plate or cover, made removable for giving access to the working parts inclosed within the case. This case is made semicircular in form at one end, forming a chamber at B for the coil of percussion-tape C, and at the other end has the wick-tube D applied to it, as shown. This wick-tube may either be made separate from the case and soldered or riveted to the end wall, as shown in Figs. 1 and 2, or the permanent side wall or plate of the case may be extended and bent around to form the tube, as shown in Fig. 5.

The upper flange or wall of the case is slotted at *a* to form an outlet for the percussion-tape, and the portion cut out is turned up in rear of said opening, forming an anvil or nose-piece, *d*, to which a spring, *e*, is fastened by soldering, riveting, or otherwise, said spring

extending down through the opening *a* nearly to the lower wall of the casing, and forming a partial partition between the chamber B for the percussion-tape and the chamber B', containing the actuating mechanism, and constituting, also, the yielding-apron over which said tape is fed outward.

Just in front of the spring *e* is arranged the feed-wheel *f*, made preferably, in the form shown—that is to say, four-sided—with a tooth or spur at each angle or corner, and of a diameter about equal to the distance between the pellets on the igniting-tape, so that the teeth will act in succession thereon as the wheel is rotated.

The size of the wheel and the number of teeth thereon may be varied, so long as the described relation between the teeth and igniting-pellets is preserved, said pellets serving as the teeth or projections upon or behind which the teeth of the wheel act for feeding the tape outward.

The wheel is secured to and rotates with a shaft, *f'*, having its bearings in the fixed side wall or plate of the case A, and is operated by means of a ring, *g*, or thumb-piece attached to its outer end, and adapted to fold down against the side of the case out of the way when not in use. Just in front of the wheel *f* is placed the hammer *h*, crossing the case A, with its upper curved end passing out through a slot, *a'*, and resting in contact with or in front of the nose-piece, and its lower or opposite end hinged either to a horizontal arm, *k'*, of an angle iron or plate, *k*, as shown in Fig. 2, or to an eye or hook struck up from the lower wall of the case, as shown in Figs. 3 and 4.

Where the plate *k* is employed its lower horizontal arm extends along the lower wall of the case sufficiently far to bring its vertical arm against the end wall of the case adjacent to the wick-tube in a line parallel, or nearly, with the hammer *h* when in a position of rest; and a spring, *m*, made by preference in U shape, is interposed between the hammer and the plate *k*, or between the hammer and the end wall of the case in the construction shown in Figs. 3 and 4, and serves to hold the hammer pressed up against the wheel *f*, as shown. The hammer and the arms of the spring resting against it are slotted longitudinally at *i*, at a point be-

low the plane of the shaft f' , to permit the teeth of the wheel to escape or pass through them after they have acted upon the hammer and overcome the tension of the spring for releasing the spring and hammer, and allowing the latter to be thrown down for exploding the pellet resting on the nose-piece.

The hammer and the spring under the arrangement described serve mutually to hold each other in place in the case without other fastening than has been described, the hammer being made removable, either with the plate k or by detaching it from the retaining-hook k' when the latter is attached to or struck up from the casing, and the spring being held in place between the hammer and end wall or plate k , as described, both are adapted to be readily removed for cleaning or renewal.

By this arrangement it will be seen that when the spring and hammer become corroded from the fulminate they can be renewed and cleaned without necessitating the removal of screws, rivets, or other fastenings.

The nose-piece is provided with vertical guards d' , extending forward toward the wick-tube, one on each side, as shown, these guards serving to prevent the fire from the pellets from being thrown off at the sides and wasted, and in connection with the nose-piece insuring its being directed toward the wick or fuse for igniting the same.

The form of the guard may be changed from that shown—that is to say, instead of being in the triangular form, it may be made in the form of a short tube, either round or polygonal, closed at its rear end by the nose-piece and

slotted to permit the movement of the hammer and the passage of the percussion-tape. The form of the spring also may be varied, that shown, however, being preferred. The vertical arm of plate k also may be shortened without interfering with its being held in place by the spring.

The operation of the several parts will be understood without further description.

I am aware that springs and hammers have been made separate and removable in gas-lighters and other devices; but I am not aware that they have been adapted to be removed without the necessity of removing the fastening screws, rivets, or other fastening devices.

Having now described my invention, what I claim, and desire to secure by Letters Patent, as an improvement in cigar-lighters, is—

1. The combination, with the inclosing-case of a pocket lighting device, of the hinged hammer h , made removable without necessitating the removal of screws or other fastenings.

2. In a pocket lighting device, the combination of the removable hammer h and actuating-spring m , arranged and operating substantially as and for the purpose described.

3. The combination of the removable hammer h , separate actuating-spring m , and suspended yielding apron e with the feed-wheel f , all arranged and operating substantially as described.

JAMES M. KEEP.

Witnesses:

GEORGE E. JEWETT,
SILAS SWARTZ.