

D. A. SMITH.
 Combined Cider Mill and Press.

No. 206,630.

Patented July 30, 1878.

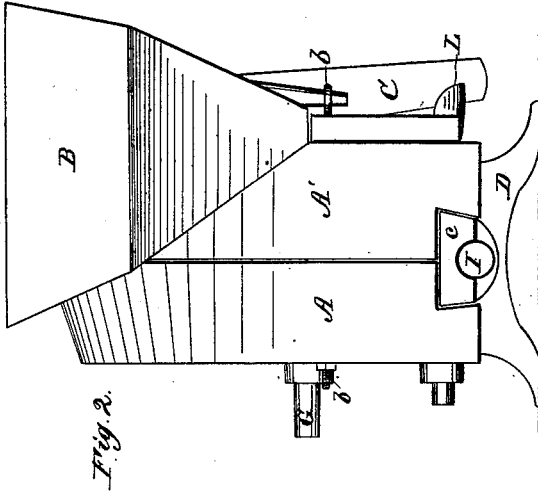

Fig. 2.

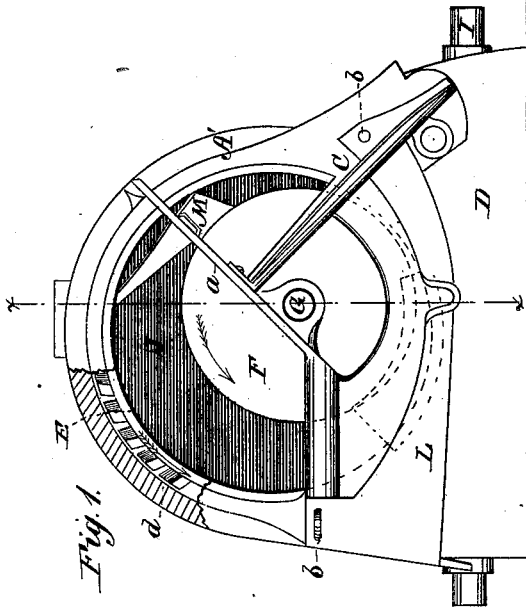

Fig. 1.

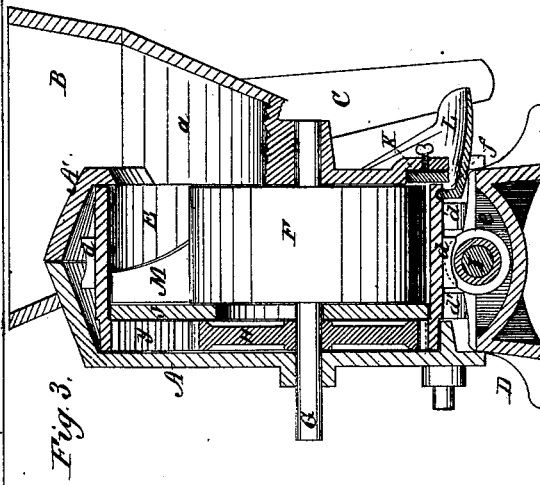

Fig. 3.

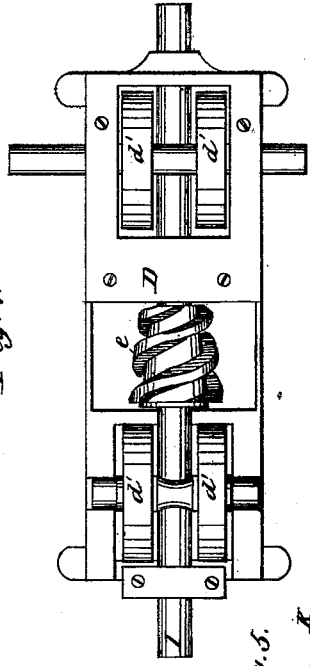

Fig. 4.

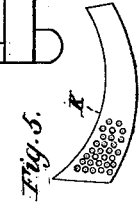

Fig. 5.

WITNESSES:

W. W. Hollingsworth
E. du. W. Byrne

INVENTOR:

D. A. Smith

BY

Wm. L. B.

ATTORNEYS.

UNITED STATES PATENT OFFICE.

DAVID A. SMITH, OF GREENCASTLE, PENNSYLVANIA.

IMPROVEMENT IN COMBINED CIDER MILL AND PRESS.

Specification forming part of Letters Patent No. **206,620**, dated July 30, 1878; application filed July 2, 1878.

To all whom it may concern:

Be it known that I, DAVID A. SMITH, of Greencastle, in the county of Franklin and State of Pennsylvania, have invented a new and Improved Combined Cider Mill and Press; and I do hereby declare that the following is a full, clear, and exact description of the same, reference being had to the accompanying drawing, forming part of this specification, in which—

Figure 1 is a front elevation with the hopper removed. Fig. 2 is an end elevation. Fig. 3 is a vertical transverse section through the line *x x* of Fig. 1, the hopper, however, being shown applied. Fig. 4 is a plan view of the base-plate, showing the parts located therein. Fig. 5 is a detail view of the cheek-plate.

My invention relates to an improved cider-mill in which the juice is expressed without previously grinding the apples into a pulp. It is an improvement upon that form of mill in which a ring, band, or hoop is guided in its revolution by rollers bearing upon its periphery, and has within the same an eccentrically-located cylinder, boss, or hub, which is attached to a shaft carrying a gear-wheel meshing with an internal gear upon the ring, so that both the cylinder and ring revolve together in the same direction, and the apples are fed between the outer periphery of the cylinder and the inner periphery of the ring, to be mashed and the juice expressed.

The invention consists in the arrangement of a partition-disk which separates the cylinder from the rigid gear connected therewith, so as to permit the mill to sit in vertical position, with the cylinder and ring on horizontal axes.

The invention also consists in the arrangement of an adjustable cheek-plate, the construction of the frame or case, and the means for driving the ring and cylinder, as herein-after more fully described.

In the drawing, A A' represent the cast-metal case of the mill, which, as will be seen, is formed in halves, each of which has a bearing for the cylinder-shaft. One of these halves, A, of the case is made plain, while the other one, A', has an opening through it, divided by an offsetting-wing, *a*, upon one side of

which wing is fitted a hopper, B, for the apples, and upon the other side of which is fitted a discharge-chute, C, for the pomace. These two parts of the case are securely fastened together by bolts or tie-rods *b*, and are coupled onto the base D of the mill by means of dovetail slots fitting over dovetail journal-boxes *c* on said base. (See Fig. 2.) Within the case is arranged the ring, hoop, or band E, which is supported at the bottom portion of its periphery by two friction wheels or rollers, *d d*, upon each side, arranged in bearings in the base. Eccentrically within this ring is arranged the hub, boss, or cylinder F, which is rigidly fixed to the horizontal shaft G, resting in bearings in the outer casing. This cylinder is made to revolve in the same direction with the ring by means of a gear-wheel, H, made rigid on the same shaft with the cylinder, which gear-wheel meshes with an inwardly-projecting set of gear-teeth, *y*, upon the ring. In giving motion to the ring and the cylinder a series of external teeth, *d*, are formed upon the periphery of the ring, and a worm, *e*, fixed upon a horizontal shaft, I, is made to engage therewith. This shaft, which is arranged in the plane of rotation of the devices, is located in bearings in the base-piece, which bearings are made of a dovetail shape, to couple the upper portion of the case, as before described.

The apples are fed into the hopper B, and pass thence into the crescent-shaped space between the outer surface of the cylinder and the inner surface of the ring, and, in being forcibly urged toward the point where the cylinder and ring approach each other nearest, are mashed and the juice expressed. The apples are prevented from coming in contact with the gear-wheel by means of a loose disk, J, which corresponds to the inner diameter of the ring E, and fits snugly inside of the same, between the cylinder F and the gear-wheel H. This disk is perforated with a circular opening to permit the passage of the cylinder-shaft; and, on account of the eccentric location of this shaft, the diameter of said opening is twice the distance between the center of the cylinder and the center of the ring and disk.

To hold the apples upon the opposite side from the disk J a curved cheek-plate, K, is let

into a recess in the inner side of the case A', and is adjusted by means of set-screws toward the end of the cylinder and edge of the ring, to make a tight joint. This cheek-plate is perforated with holes, (see Fig. 5,) and as the juice is expressed from the apples it passes back through the unbroken apples and out through these perforations into a trough below. L is this trough, which is curved to correspond with the periphery of the ring, and which is provided also with a flange, *f*, Fig. 3, which enters a groove in the outer face of the ring, to prevent the loss of any of the juice. After the juice has been pressed from the apples, the dry pomace passes up the opposite side of the cylinder, where it is removed by a scraper, M, and drops out into the chute C, which carries it away.

In order to secure a grinding as well as a crushing action, the surface of the cylinder F may be geared to move a little faster than the inner surface of the band or ring.

Having thus described my invention, what I claim as new, is—

1. The loose disk J, having a perforation to

accommodate the eccentric location of the cylinder, combined with said cylinder and ring, and interposed between the cylinder and its gear-wheel, substantially as described.

2. The combination, with the cylinder F and ring E, of the cheek-plate K, located in a recess in the casing A', and made adjustable, substantially as described.

3. The ring E, having an external set of gear-teeth, in combination with the base-plate having friction-rollers *d*, arranged upon opposite sides of the projecting gear-teeth, and a shaft, I, provided with a worm engaging with the teeth, as described.

4. The combination, with the ring E and cylinder F, of the case A A', made in sections, the section A' having an opening divided by an offsetting-wing, *a*, and provided with a hopper upon one side of said ring, and a scraper and chute for the pomace upon the other side, as set forth.

DAVID A. SMITH.

Witnesses:

SAM. P. HOSTETTER,

I. HOSTETTER.