

C. W. CORR.
Power-Hammer.

No. 206,665.

Patented Aug. 6, 1878.

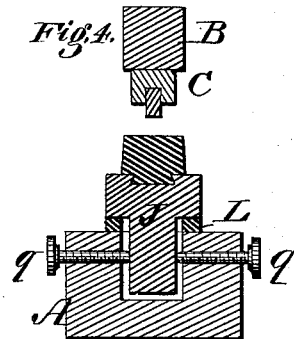
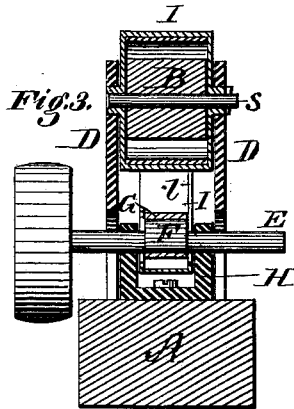
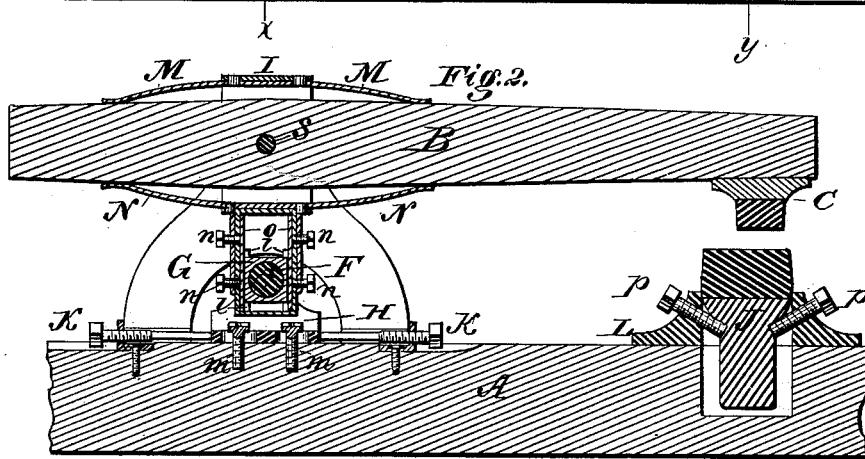
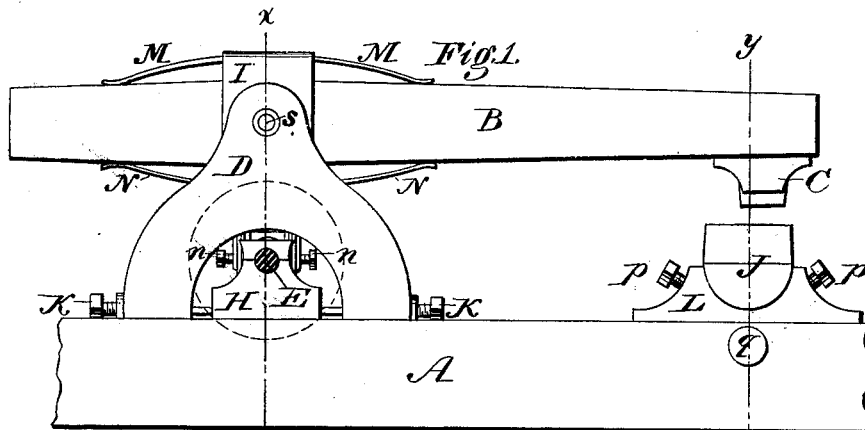

Witnesses:

Donn P. Twitchell,
Will W. Dodge

Inventor:

C. W. Corr
By his attys
Dodge & Son

UNITED STATES PATENT OFFICE.

COLUMBUS W. CORR, OF CARLINVILLE, ILLINOIS.

IMPROVEMENT IN POWER-HAMMERS.

Specification forming part of Letters Patent No. 206,665, dated August 6, 1878; application filed September 3, 1877.

To all whom it may concern:

Be it known that I, COLUMBUS W. CORR, of Carlville, in the county of Macoupin and State of Illinois, have invented certain Improvements in Tilt-Hammers, of which the following is a specification:

My invention relates to tilt-hammers; and the improvements consist in an oscillating carriage of peculiar construction, in which the hammer-beam is mounted, said carriage being oscillated by means of an eccentric working in a sliding block mounted in the lower part of the same; in mounting the eccentric-shaft in an adjustable frame or block, whereby the relative positions of the eccentric and the pivot of the hammer may be varied to regulate the length of stroke and the distance between the hammer and its anvil; and in various details of construction, as hereinafter more fully explained.

Figure 1 is a side elevation of my improved hammer; Fig. 2, a longitudinal vertical section of the same; Fig. 3, a vertical cross-section on the line *xx* of Fig. 1, and Fig. 4 a similar section on the line *yy* of the same figure.

In the drawing, A represents the bed of the machine, to which I secure two upright standards, D. Between these standards, and journaled in the same, is an oscillating carriage or cradle, I, which is open through its upper portion in a direction longitudinally of the machine, as shown in Figs. 2 and 3, said opening being provided on its upper and lower faces with strong steel springs M and N, which extend some distance in front and rear of the carriage or cradle I, as shown in Figs. 1 and 2. These springs, as shown, are of semi-elliptical form, and are placed with their outer ends approaching each other. B is the hammer-beam, which passes between the springs M and N, through the open upper portion of the carriage or cradle I, and is pivoted on a shaft, S, which has its ends passed centrally through the journals of the carriage or cradle I, as shown in Figs. 1 and 3.

The lower portion of the carriage or cradle I is extended downward, and made in the form shown in Figs. 2 and 3, consisting of a slotted arm having inwardly-projecting flanges *l* at the sides of the slot, as shown in

Figs. 2 and 3. Within this slotted arm is placed a sliding block, G, which is prevented from moving laterally by means of the flanges *l* just referred to. The block G is provided with a circular opening to receive an eccentric, F, mounted on a transverse shaft, E, to which motion is imparted from any convenient source. In order to insert the block G into its place in the slotted arm of the carriage or cradle I, the flanges *l*, by which the block is retained in place, are cut away at a point above which the block never passes when the machine is in operation, so that the block may be readily passed in from one side and passed down between the flanges to the proper position.

The shaft E is mounted in bearings or boxes on a longitudinally-adjustable block or carriage, H, said carriage being held from raising off the bed-plate by means of T-headed bolts *m* passing through longitudinal slots in said carriage into the bed of the machine, and being adjusted longitudinally of the machine by means of screws K passing through stationary blocks on the bed of the machine, and having their ends arranged to bear against the ends of the block or carriage H, as clearly shown in Figs. 1 and 2.

From the above description it will be seen that when the shaft E stands directly below the shaft S the stroke of the hammer will be longer than when the shaft E is moved forward or rearward of the shaft S, their distance from each other being less at that time than at any other.

When it is desired that the hammer shall rise but a short distance from the face of its anvil J, the carriage or block H is moved backward of the shaft S, throwing down the hammer C; but when it is desired to increase the distance between them, for hammering large objects or the ends of long ones, the carriage H is so adjusted as to bring the shaft E, with its eccentric F, forward of the shaft S, thus throwing up the outer end of the beam B, and with it the hammer C, thus greatly increasing the distance between them.

It will be observed that a very short movement of the carriage or block H will be sufficient to give a wide range to the movements of the hammer.

J represents the anvil, which, as shown in Fig.

1, has its ends made of semicircular form and seated in bearings of a corresponding form in the anvil-support L, whereby the anvil may be turned or rocked in its seat, so as to give any desired inclination to its upper face, and still give a firm and solid support to the anvil in whatever position it may be placed. The anvil support or bed L is mortised to receive a depending arm, with which the anvil J is provided, and against the sides of which arm screws *q* are arranged to bear to hold the anvil in the position to which it is adjusted. Two screws, *p*, are passed through the anvil support or bed L, and arranged to bear one against the front and the other against the rear side of the anvil, for the purpose of adjusting the same. Any desired form of face or die may be secured to the anvil, and also to the hammer, by means of a dovetail joint or other suitable means.

By imparting motion to the beam through springs M and N a dead-stroke is obtained, while at the same time the shock and jar to the machinery incident to a direct connection of the beam and operating mechanism are avoided.

In order to compensate for wear, and to regulate perfectly the fit of the sliding block G, I interpose between its sides and the walls of its slot metallic plates or bearing-surfaces O, which are moved to or from the block G by means of screws N, as shown in Fig. 2.

The advantages of my construction are apparent, as it not only prevents the jar from being imparted to the frame of the machine and the operating mechanism, but also relieves the carriage or cradle J of such jar or shock in the same manner—a result not accomplished by any other machine of which I am aware. This construction gives great strength to the parts, and produces a very efficient and durable machine.

I am aware that a hammer has been actuated by means of springs, and that a hammer-beam has been mounted in a rocking frame

and driven by means of three interposed adjustable rubber springs, and also that the hammer-beam has been supported on pointed pivots, and the spring-supporting frame journaled on the hammer-frame; and to these forms of construction I make no claim.

My springs are advantageous, in that they give a better balance and a more elastic motion of the hammer, and in that, unlike the rubber springs, which are of ever-varying quality, and which require frequent adjustment, they are always of the same strength and elasticity, and never require adjusting. My mode of sustaining the helve or beam is advantageous, in that it affords a longer bearing and larger wearing surface, and that it consequently prevents side play of the helve.

Having thus described my invention, what I claim is—

1. In a power-hammer, the combination of the rocking cradle I, the independently-vibrating hammer-beam pivoted therein, and the two semi-elliptic metal springs M and N, secured in the top and bottom of the cradle, respectively, with their ends bearing on the beam on opposite sides of its pivot, as shown and described.

2. In combination with the rocking cradle having the hammer-beam and springs mounted therein and the slotted arm depending rigidly therefrom, the eccentric F, and the sliding block G mounted thereon within the slotted arm.

3. In combination with the rocking cradle and the sliding block G, mounted in its slotted arm, the eccentric F, having its shaft mounted in longitudinally-adjustable bearings.

4. In combination with the shaft E, having the eccentric mounted thereon, and arranged to operate the hammer-beam in the manner described, the movable bearing H and screws K.

COLUMBUS WASHINGTON CORR.

Witnesses:

WM. COGAN,
JAMES H. CAMPBELL.