

C. W. HORNOR.
Track-Raiser.

No. 206,673.

Patented Aug. 6, 1878.

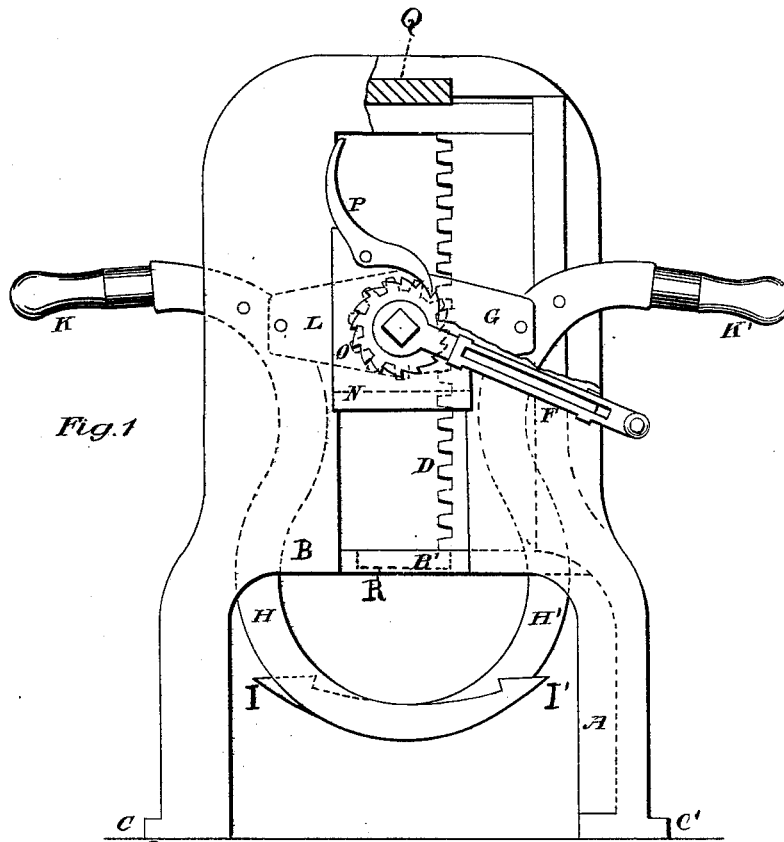

Fig. 1

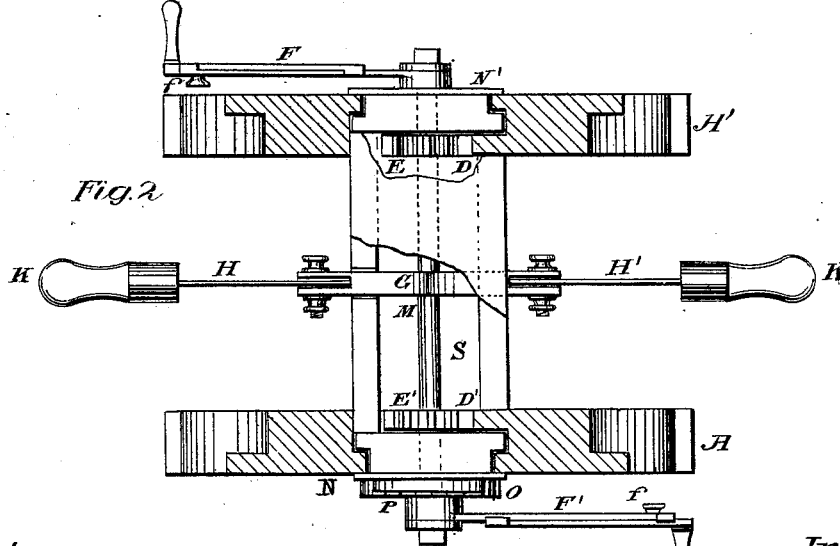

Fig. 2

Attest
Geo. Allan Dubois
S. W. Reeves

Inventor
Caleb W. Hornor.

UNITED STATES PATENT OFFICE.

CALEB W. HORNOR, OF PHILADELPHIA, PENNSYLVANIA.

IMPROVEMENT IN TRACK-RAISERS.

Specification forming part of Letters Patent No. **206,673**, dated August 6, 1878; application filed June 13, 1878.

To all whom it may concern:

Be it known that I, CALEB W. HORNOR, of No. 1636 Walnut street, city of Philadelphia, and State of Pennsylvania, have invented a new and useful Improvement in Railroad-Jacks, which improvement is fully set forth in the following specification:

The object of my invention is to furnish a machine for lifting materials used in laying and repairing railroad-tracks, &c., portable, easily manipulated, expeditious, and self-sustaining when wound up, thus dispensing with the lever, and saving the cost of a laborer now employed for weight on the long arm of the lever, by combining in a railroad-jack, as shown in the accompanying drawings, the crank-handles, pinion-wheels, racks, and shaft running through blocks that slide on the fixed upright supports. These slides, for strength, are firmly connected by the sheath of the shaft. The shaft gives bearing to a walking-beam and hook or two hooks grasping on both sides the material to be raised, so as to force up with full tension by means of the walking-beam both sides, thus offering a uniform bearing on the piece beneath for the imposed weight.

The machine is constructed of four uprights, combined in two opposite halves or pairs. Each pair consists of two parallel uprights, A A', or standards, inclined toward each other at B, and connected at the top, also united by a cross-piece, B', toward the lower extremities, where they are more separated and prolonged to a convenient length to stand over the article to be lifted. The two feet C C' are somewhat expanded to prevent sinking in the earth. On the inside of one upright is a rack, D, and fitted to run in this is a pinion-wheel, E, on a shaft, M, projecting beyond the uprights. At the outer end of this shaft, on each side, is an expanding crank-handle, F, which may be used as a simple handle, or, to increase the windlass-power thereof, may be elongated and fixed by a thumb-screw, *f*. On the shaft, between the pinion-wheel of each side or half, is balanced a short walking-beam, G. In either extremity of this beam is fastened, by bolt and thumb-screw, one blade of a pair of hooked forceps or tongs, H H',

having the lower extremity curved inward and terminating in a sharp point barbed on the upper side, I I'. At the other end each has a handle, K K', directed outward at an angle convenient to be used by the operator in adjusting the barbed points of the blades underneath the material to be raised. These blades have two or more holes, L, &c., for bearing, and that their elevation may be changed at will. On the outer side of each pinion-wheel, the shaft runs through and has its bearing on a flattened block, N N', with parallel vertical sides grooved to fit flanges projecting from each standard, on which they slide obedient to the crank. Next the crank is fastened a ratchet-wheel, O, running against the grooved block. On the block is attached a catch, P, to fit the notches in the wheel, to sustain the force of the machine when supporting a weight.

The two opposite halves or pairs, as above shown and described, are firmly connected together by cross-ties or couplings at the top, Q, and toward their lower extremities, R. The slides N N' are rigidly united by a casing, S, for that part of the shaft between them, making, in effect, except for the working of the walking-beam and pinion-wheels, a solid transverse block, having for its outer extremities these slides or grooved blocks.

I am aware that my patent of December 12, 1876, No. 185,178, is for a rack, pinion-wheel, &c.; but in the present case there are two sets of double standards, two racks, and two pinions, so that the bearing on the shaft may be between them. The slides N N' also, at the top and bottom, are rigidly connected. The crank-handle is duplicated, and, to increase the power, is made extensible.

I claim as my invention—

The combination, in a railroad-jack, of the racks D D', pinions E E', shaft M, extension crank-handles F F', walking-beam G, tongs H H', transverse casing S, having for its ends slides N N', all as described and shown.

CALEB W. HORNOR.

In presence of—

GEO. R. VAN DUSEN,
S. U. REEVES.