

P. F. FERNANDEZ.
Shutter-Fastening.

No. 206,713.

Patented Aug. 6, 1878.

Fig. 1.

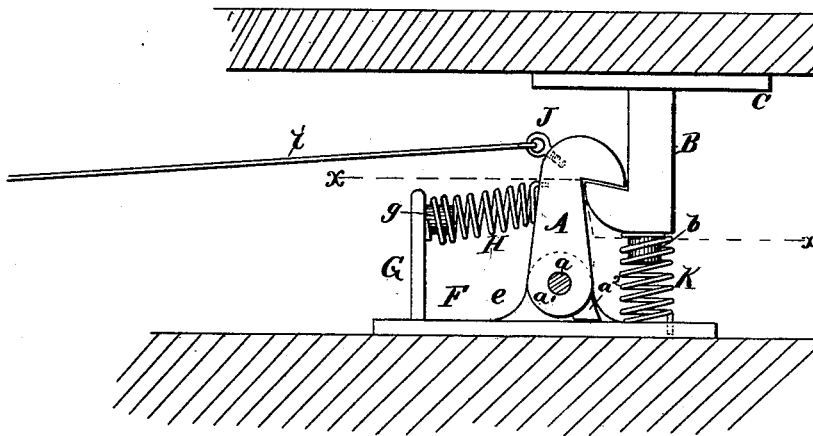

Fig. 2.

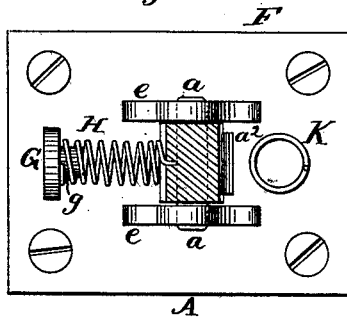
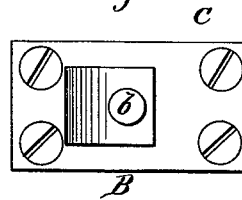

Fig. 3.



WITNESSES:

Henry N. Miller
C. Sedgwick

INVENTOR:

P. F. Fernandez
BY Mumford & Co

ATTORNEYS.

UNITED STATES PATENT OFFICE.

PEDRO F. FERNANDEZ, OF SAN JUAN, PORTO RICO, WEST INDIES.

IMPROVEMENT IN SHUTTER-FASTENINGS.

Specification forming part of Letters Patent No. **206,713**, dated August 6, 1878; application filed July 2, 1878.

To all whom it may concern:

Be it known that I, PEDRO F. FERNANDEZ, of San Juan, in the Island of Porto Rico, West Indies, have invented a new and useful Improvement in Door and Shutter Fasteners, of which the following is a specification:

My invention relates to a method of holding doors or window-shutters securely in position when open, by means of hooks engaging with each other and actuated by springs; and it is applicable to doors and shutters of dwelling and other houses, doors of churches and places of amusement, and cabin and other doors on board of ships and other vessels.

The invention consists in a novel construction of hooks adapted to engage with each other; a novel arrangement of springs for insuring the proper engagement of said hooks, whereby provision is made for holding a door or shutter steadily and firmly when open, and readily releasing it when it is to be closed.

Similar letters of reference indicate corresponding parts.

The accompanying drawing represents a fastener embodying my improvements.

Figure 1 represents a horizontal section of a portion of a wall and of a door or shutter with the fastener in position thereon. Fig. 2 is a sectional view taken on the line *x x* of Fig. 1, looking toward the wall. Fig. 3 is a face view of the hook attached to the door or shutter.

The various parts of the fastener are made of metal, and, with the exception of the springs, they may be made of either cast or wrought iron, as preferred. When they are to be exposed to the weather, they should be galvanized or bronzed in order to protect them.

The hook A (shown in the drawing) is formed with a rounded heel, *a*¹, and a flat-surfaced projecting toe, *a*², opposite to each other, and at right angles to said heel and toe are two studs or pins, *a a*, projecting laterally, and serving as pivots for the hook to oscillate upon. These pivots *a a* have their bearings in perforated lugs *e e* formed on or attached to a plate, F, which is adapted to be fastened to the wall by screws, or in any other suitable manner.

From the plate F, in rear of the hook A, extends an arm, G, having a boss or stud, *g*, near its outer end, on the side toward the hook. A coiled spring, H, is arranged, with one end

bearing against the arm G and the other end bearing against the back of the hook A. The spring is held in place by engagement with the boss *g* at one end, and by having the end of its wire at the other end inserted in a recess in the back of the hook, and it serves to hold the hook in the position shown in Fig. 1, with the toe *a*² bearing against the face of the plate F. The toe *a*² prevents the hook from swinging forward any farther than the position shown; but the rounded heel *a*¹ allows it to swing backward, in order to engage with or be disengaged from the other hook, in order to fasten or unfasten the door or shutter.

On the back of the hook A, near the outer end, is a ring or eye, J, which may either be cast or formed with the hook, or may consist of a screw-eye inserted in a tap-hole formed in the hook. To this eye or ring J is attached one end of a cord or chain or a wire, *i*, the other end of which passes between the wall and the door or shutter to the sill or frame of the door or window, and may be provided with a ball or knob at the end. It may pass through staples or through a gimlet-hole bored in the frame for holding it in place and guiding it in a straight line.

The hook B is either cast with or rigidly attached to its carrying-plate C, which plate is adapted to be secured to the door or shutter by screws or otherwise. At the free end of the hook is a boss or stud, *b*, extending outward therefrom in line with the length of the body of the hook, for engagement with the outer end of a coiled spring, K, the inner end of which is rigidly attached to the plate F.

The hooks being secured one to the wall and the other to the door or shutter, as shown in Fig. 1, when the door or shutter is opened the inclined surface of the rigid hook B slides over the inclined surface of the pivoted hook A, causing the latter to swing backward until the points of the two hooks clear each other, whereupon it is immediately pressed forward again, so as to cause the faces of the two hooks to engage with each other, as shown in Fig. 1, and prevent the door from being closed. At the same time the boss or stud *b* enters the outer end of the spring K, slightly compressing said spring and causing it to bear against the hook B with a tendency to push the door

or shutter in a direction to close it, in consequence of which the door or shutter is held firmly and steadily in position, and is prevented from vibrating or rattling, because the faces of the two hooks are pressed closely against each other by the expanding action of the spring.

When the door or shutter is to be closed, the wire *i* is pulled so as to cause the hook A to swing backward away from the hook B, whereupon the spring K expands sufficiently to push the door or shutter in a direction away from the wall and start it in the direction of closing.

By the construction and arrangement of parts as above described, a fastener is produced which possesses many advantages. It is self-acting, simple, strong, durable, and reliable. It works easily, and is not liable to get out of order. It avoids the necessity of leaning out of a window to fasten or unfasten a shutter, and the consequent danger and exposure to the weather.

Having thus fully described my invention, what I claim as new, and desire to secure by Letters Patent, is—

1. The hook A, having the journals *a a*, rounded heel *a'*, and flat-surfaced toe *a''* formed therewith, in combination with the plate F and its journal-bearings *e e*, the arm G and its boss or stud *g*, and the coiled spring H, as shown and described, for the purpose specified.

2. The rigid hook B, having the boss or stud *b* formed thereon, in combination with the swinging hook A and its actuating-spring H, and the coiled spring K attached to the plate C, as shown and described, for the purpose specified.

PEDRO F. FERNANDEZ.

Witnesses:

EDW. COURVY,

U. S. Consul.

W. H. LATIMER,

Consulate of the Netherlands.