

W. MARTIN, Jr., D. R. DAWSON & R. ORCHAR,
Sewing-Machine.

No. 206,743.

Patented Aug. 6, 1878.

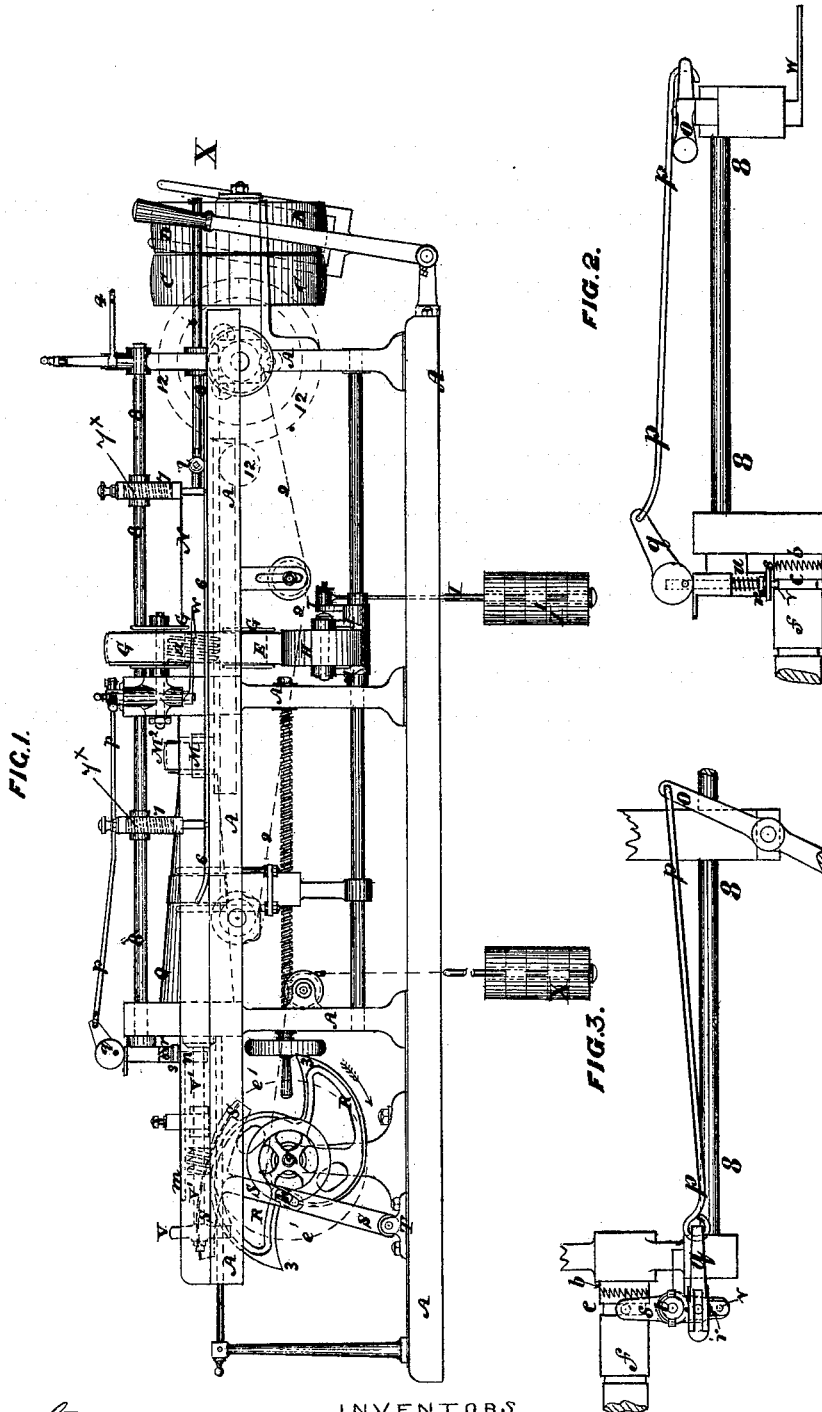

WITNESSES

Chas J. Gooch
L. Blond Burdett

INVENTORS

William Martin (the younger)
David Russell Dawson
and Robert Orchar
By Knight & Co. attorneys

W. MARTIN, Jr., D. R. DAWSON & R. ORCHAR.
Sewing-Machine.

No. 206,743.

Patented Aug. 6, 1878.

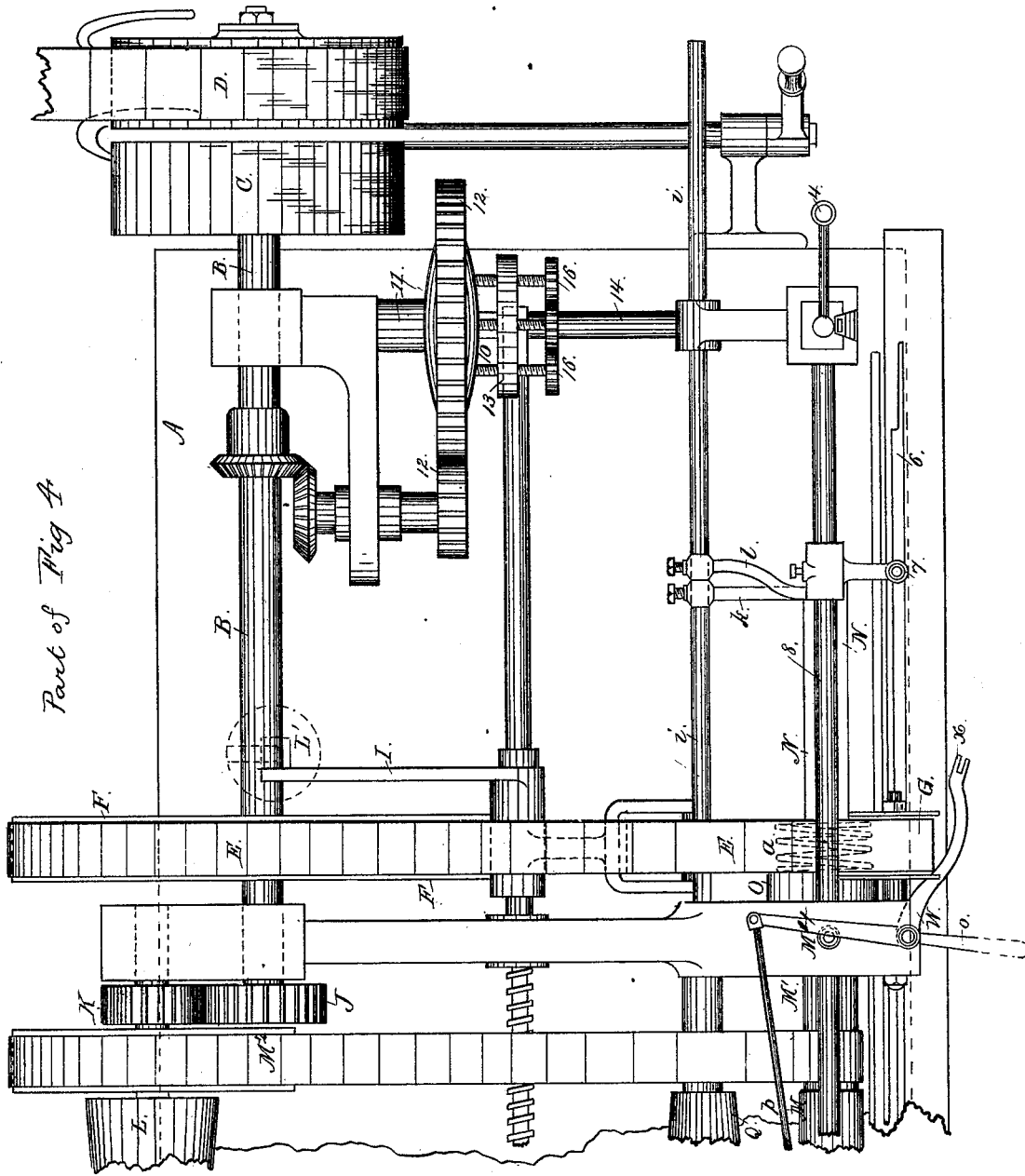

Part of Fig 4

WITNESSES:
Chas. J. Cook
L. Blond Burdett

Inventors:
William Martin the younger
David Russell Dawson
and Robert Orchar
 By *Knight Bros* attys

W. MARTIN, Jr., D. R. DAWSON & R. ORCHAR.
Sewing-Machine.

No. 206,743.

Patented Aug. 6, 1878.

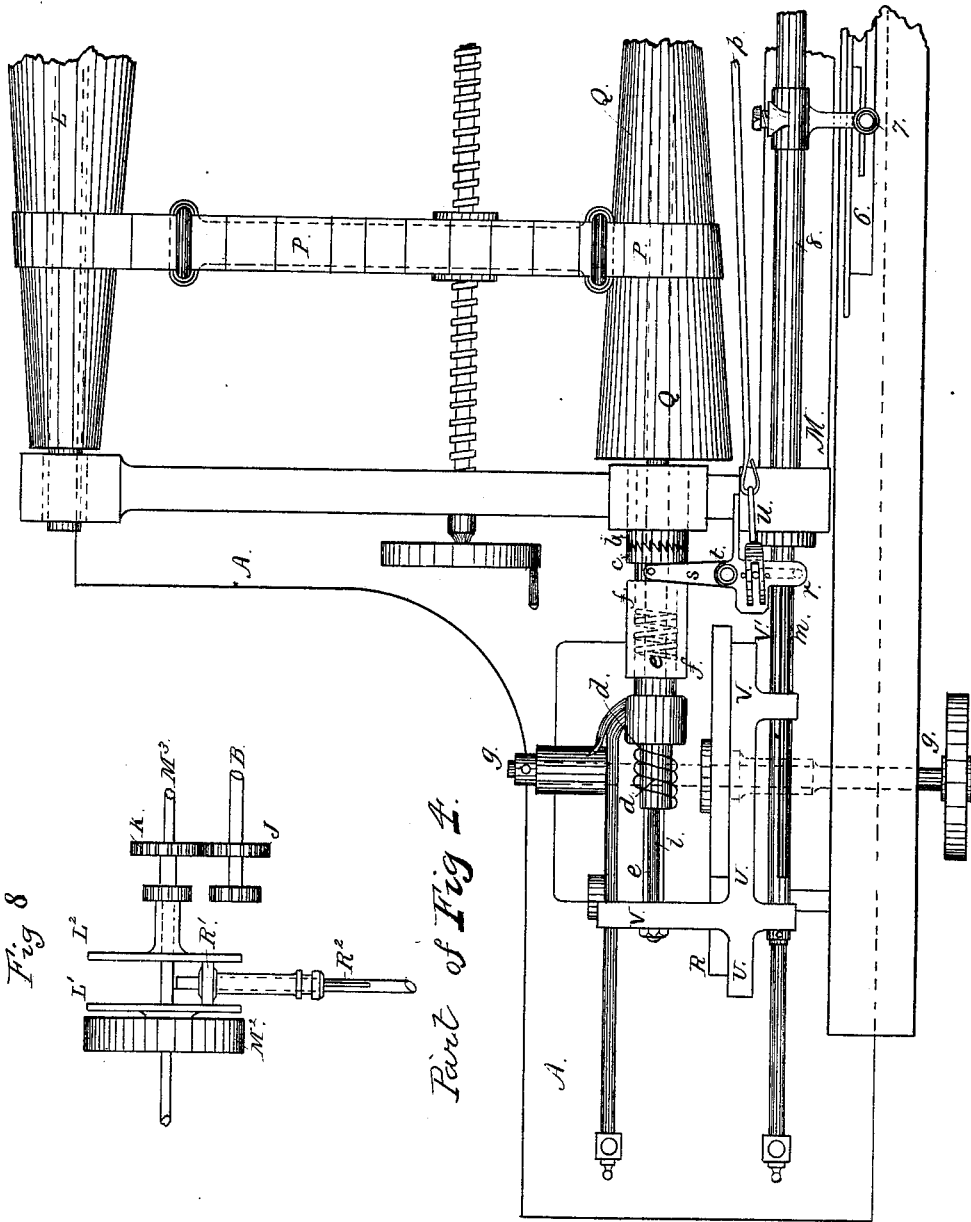

Fig 8

Part of Fig 4.

WITNESSES:
Chas J. Coock
Le Blond Gurdett

Inventors:
William Martin the younger
David Russell Dawson
and Robert Orchard
 By *Knight Bros* attys

W. MARTIN, Jr., D. R. DAWSON & R. ORCHAR.
Sewing-Machine.

No. 206,743.

Patented Aug. 6, 1878.

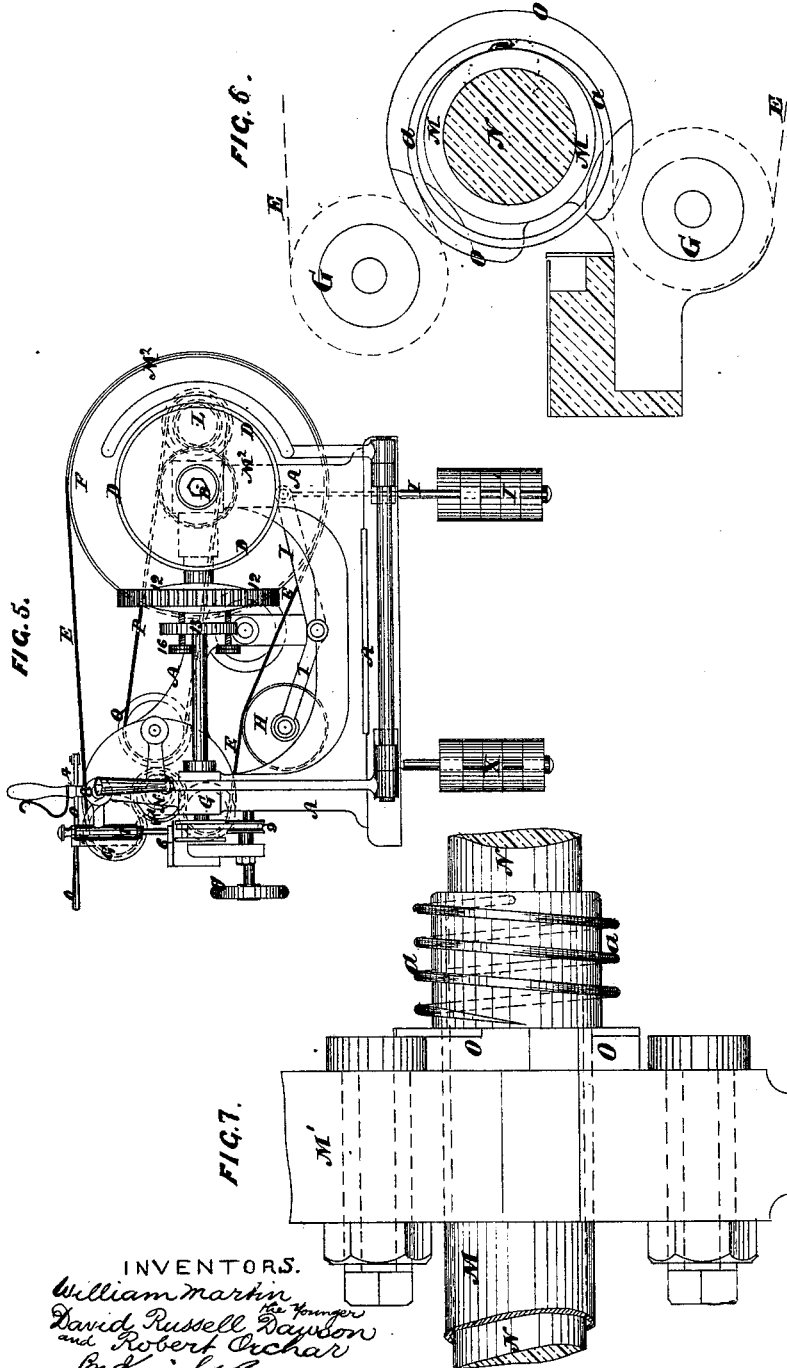

WITNESSES.
Chas J. Looch
L. B. Lord Purdett

INVENTORS.
William Martin
David Russell Dawson
and Robert Orchar
Per Knight & Co. attorneys.

UNITED STATES PATENT OFFICE.

WILLIAM MARTIN, JR., DAVID R. DAWSON, AND ROBERT ORCHAR, OF
DUNDEE, NORTH BRITAIN.

IMPROVEMENT IN SEWING-MACHINES.

Specification forming part of Letters Patent No. **206,743**, dated August 6, 1878; application filed
May 18, 1877: patented in England May 6, 1876.

To all whom it may concern:

Be it known that we, WILLIAM MARTIN, the younger, director, DAVID RUSSELL DAWSON, secretary, both of Laing's Patent Overhead Hand Stitch Sewing Machine Company, limited, and ROBERT ORCHAR, engineer, all of Dundee, in the county of Forfar, North Britain, have invented Improvements in Laing's Overseam Sewing-Machine, of which the following is a specification:

Our said invention relates to improvements in some of the details of that sewing-machine for which Letters Patent were granted to James Laing, dated the 27th day of April, 1875, and numbered 162,665.

The invention relates, first, to certain improvements in means for actuating the thread-barrel and threading the needle; second, to means for guiding the spiral needle; third, to a driving-cone, arranged in the same plane as the axis of the barrel-tube, for imparting variable motion; fourth, to a presser carried in brackets, within which coiled springs are arranged, which by their action impart the desired amount of stress to the presser; fifth, to certain means whereby the rate of travel of the pitch-feeding chain, and also the degree of tension on the spiral needle, may be regulated.

In order that the overseam sewing-machine as constructed with these improvements may be properly understood, we now proceed more particularly to set forth the system, mode, or manner in or under which our said improvements are or may be used or carried into practical effect, reference being had to the accompanying sheets of drawings, and to the letters and figures marked thereon—that is to say:

Figure 1 of the drawings, hereunto appended, is a front elevation, Fig. 4 a plan, and Fig. 5 an end elevation of the overseam sewing-machine hereinbefore referred to, with the improvements constituting our said invention shown in conjunction therewith.

As shown by these figures, the improved machine consists of a rectangular frame-work, A, supporting at its rearward side a shaft, B, which is rotated by a belt passed round the pulley C of the fast and loose pulleys C D, sit-

uate on one end of the shaft. Another pulley, F, is also fixed on the shaft B, and from it motion is communicated by the band E to a cylindrical spiral hook or needle, *a*, round which the band E passes, and which is similar in construction to the spiral hook or needle of the overseam sewing-machine described in the aforesaid specification of the said James Laing, it being pointed at the end which first pierces the cloth or fabric, and at its opposite end formed with a hook, by which the thread used in sewing is held.

The band E passes from the pulley F round two other pulleys, G, in the direction shown at Fig. 5 of the drawings, and it is stented by a roller, H, carried in a lever, I, centered on the lower part of the framing A, and weighted at I'. A spur-wheel, J, is fixed on the shaft B and geared with a corresponding pinion, K, on the axis of the driving-cone L, on which a pulley, M², is also secured, and by a belt or band passed round the said pulley M² the thread-barrel N of the machine and the tube M containing it are rotated. The said tube M is supported at the end thereof (marked M¹) in a solid cylindrical bearing, M⁴, made in the framing of the machine, thereby avoiding the anti-friction rollers employed to support the corresponding end of the tube M in the machine, as shown and described in the aforesaid specification of the said James Laing.

Another part of our invention consists in dispensing with the inner roller employed to guide the needle in the machine, as described in the aforesaid specification of the said James Laing, and providing instead thereof a fixed inner guide, O, (seen in detail at Figs. 6 and 7,) which surrounds the thread-barrel tube M and is secured to the front center gable or standard M⁴ of the framing A. By this means lateral motion of the needle is prevented.

From the driving-cone L rotary motion is communicated by the belt or band P to the front driving-cone Q, the shaft or spindle whereof carries a clutch-box, *b*, into which a clutch, *c*, sliding on a feather on its shaft is geared while the needle is sewing, and disengaged when it is required to supply thread to the needle.

At the back of the clutch *c* a box or cham-

ber, *f*, containing a spiral spring, *c*, is formed, and on the extremity of the spindle of the clutch *c* a tangent-screw, *d*, is secured and geared with a worm-wheel, *e'*, fixed on a shaft, *g*, lying at right angles to the axis of the cone Q. On the shaft *g* we prefer to fix a double cam, R, the contour of each section of which is approximately that of an involute curve having a deep step, or a single cam may be employed.

The curved surface of the cam bears, while the needle is sewing, upon a pin or tumbler, *h*, carried in a slot or hole made in the lever S, which is centered at its lower end on a bracket or foot-step, T, and formed at its upper extremity with a toothed quadrant, which gears into a horizontal rack formed at U, Fig. 4, in a saddle, V, connected to the spindle V' of the thread-barrel N, and to a spindle or rod, *i*, which passes through the bearings of the cone Q and of the tangent-screw *d*. On this spindle or rod the thread drag or tension *k* and the knife *l*, by which the end of the thread is severed from the cloth or fabric being sewed, as in the machine described in the aforesaid specification of the said James Laing, are carried. The saddle V is further connected to a rod or spindle, *m*, at one end of which a disk or striker, *n*, is fixed, and in connection with the said striker an apparatus consisting of a handle or lever, *o*, connecting rod or link *p*, eccentric *q*, crank *r*, and lever *s* are provided. The eccentric and crank *q* and *r* are situate, respectively, at the upper and lower extremities of a vertical rod carried in a bracket attached to the framing A, while the lever *s* is centered on a separate rod or pin, *t*, also carried in the bracket. The arrangement is illustrated in enlarged detail at Figs. 2 and 3. One end of the lever *s* is connected to the crank *r* by a pin, *v*, which passes downward through a slot in it, while the opposite end of the said lever *s* is attached to the clutch *c*, as seen in plan at Fig. 4 of the drawings. The threader *x*, by which the bight or loop of thread is delivered to the needle, as in the machine described in the aforesaid specification of the said James Laing, is situate on and projects toward the needle from the axis of the horizontal needle *o*. Weights X are attached to the quadrant-lever S, as shown.

The operation of this apparatus, which is employed instead of the screw actuating the thread-barrel N, as described in the aforesaid specification of the said James Laing, is as follows: While the needle is sewing with a thread previously supplied to it, the clutches *b* and *c* are in gear with each other, whereby rotary motion is communicated to the cam R through the intervention of the tangent-screw *d* and worm-wheel *e'*. This motion of the cam R, which is in the direction of the arrow, Fig. 1, forces the lever S backward, which lever, being geared by the rack formed on the saddle V with the spindle V' of the thread-barrel N, also draws the said barrel backward

into its tube M as the thread becomes unwound therefrom in the manner described in the aforesaid specification of the said James Laing. This backward motion continues until all the thread has been unwound from the barrel N, at which time the part 3 of the cam is bearing against the pin or tumbler *h*. The part 3 having passed the pin or tumbler, the barrel N is again pushed out to its full extent by the weights X drawing forward the lever S, and the clutches *b* and *c* are on the said forward motion thrown out of gear with each other by the striker *n* acting against the pin *v*. The attendant then removes a new piece of thread from the hook 4, places a loop of it over the part *x* of the threader, and by means of the lever *o* presents the loop to the eye or hook of the needle, at the same engaging the clutches *b* and *c*, which has the effect of again setting in motion the cam R, and the new piece of thread having been wound on the barrel N, as set forth in the aforesaid specification of the said James Laing, the sewing is proceeded with.

The engaging and disengaging of the clutches *c* and *b* may be described as follows: When the lever *o* is actuated so as to present the thread to the needle the spindle *n* is forced upward by the eccentric *q*, to which it is connected, and the pin *v* is thereby brought above the level of the striker *n*. The lever S being now set free, the spring acting on the back of the clutch *c* forces the said clutch into gear with the clutch *b*, and the sewing is continued until the barrel N has been moved back to the extremity of its rearward stroke, from which it is again brought forward by means of the weights X, as already described.

The cams R employed vary in extent of travel according to the work requiring to be sewed; or, in place of the cam, a sliding wedge or inclined surface may be used, which, as it is moved, acts upon the lever S and draws it back, thereby lifting the weight until, sliding out of contact with the lever, it affords a sudden relief thereto, so that the lever is drawn forward by the falling of the weights, and the thread-barrel N is again forced out.

The driving-cone Q for the variable motion is, as seen in the drawings, placed in the same horizontal plane as the axis of the tube M of the thread-barrel N, instead of being placed in a higher plane, as shown in the drawings annexed to the aforesaid specification of the said James Laing; and this arrangement permits of a bar or rod being placed along the front of the machine to carry the improved presser 6, by which the fabric being sewed is held down on the table and pitch-feeding chain of the machine.

The improvement in the presser consists in carrying it in brackets 7, at whose interiors coil-springs 7* are placed, the said brackets being attached to the bar 8, laid parallel to the length of the machine, so that when it is desired to move the presser out of contact with the fabric being sewed all that is necessary is for the at-

tendant to lift the presser. The springs in the brackets 7 force the presser down on the cloth with the requisite stress.

In our machine a finer adjustment of the rate of travel of the pitch-feeding chain 9 is obtained than in the machine described in the aforesaid specification of the said James Laing by the addition of friction-disks 10 and 11 to the spur-gearing 12 and by introducing a friction-clutch, 13, on the shaft 14, that drives the pitch-feeding chain by which the length of the stitches is regulated, as well as the tension on the spiral needles, that tension being thereby prevented from attaining an extent which would be dangerous to the needle by virtue of the friction-clutch slipping before that degree of tension is reached.

The clutch consists of the plate or disk 13, secured on the shaft 14, and through which screws 16 are passed, these bearing against the loose friction-disk 10, so as to force it into contact with the wheel 12, and the said wheel into contact with the fixed friction-disk 11.

A modification of the invention (shown on the drawings at Fig. 8) consists in dispensing with the reversed cone-pulleys L and Q and employing friction-plates L¹ and L², rotating in opposite directions, for driving a friction-roller, R¹, between them on a shaft, R², at right angles to the shaft M³ of the friction-plates, and so that by moving the friction-roller inward or outward from the axis of the friction-plates the requisite variable motion is obtained.

Having now described and particularly ascertained the nature of our said invention, and the system, mode, or manner in or under which

the same is or may be used or practically carried into effect, we would observe, in conclusion, that what we consider to be novel and original, and therefore claim and desire to secure by Letters Patent, is—

1. The combination of cam R, lever S, provided with pin *h* and toothed quadrant, rack U, spindle V', threader *w*, lever *o*, clutches *b* and *c*, and devices connecting such parts, as and for the purposes set forth.

2. The combination, with the needle of the fixed inner guide O, thread-barrel tube M, and standard M⁴, as and for the purposes set forth.

3. The combination, with the driving-cone L, of the front driving-cone Q, clutches *b* and *c*, spring *e*, tangent-screw *d*, worm *e'*, thread-barrel N, and connecting mechanism, as and for the purpose set forth.

4. The combination of the presser 6, brackets 7, parallel bar 8, and coiled springs 7^x, as and for the purpose set forth.

5. The friction-disks 10 11, spur-gearing 12, friction-clutch 13, and shaft 14, for regulating the rate of travel of the pitch-feeding chain and the degree of tension on the spiral needle, substantially as set forth.

In witness whereof we have signed our names to this specification in the presence of the subscribing witnesses.

W. MARTIN, JR. [L. S.]
DAVID R. DAWSON. [L. S.]
ROBERT ORCHAR. [L. S.]

Witnesses:

JOHN DUFF,
AUGUSTUS PIRVIN.