

W. G. BARNES. Riding-Cultivator

No. 206,763.

Patented Aug. 6, 1878.

Fig. 1.

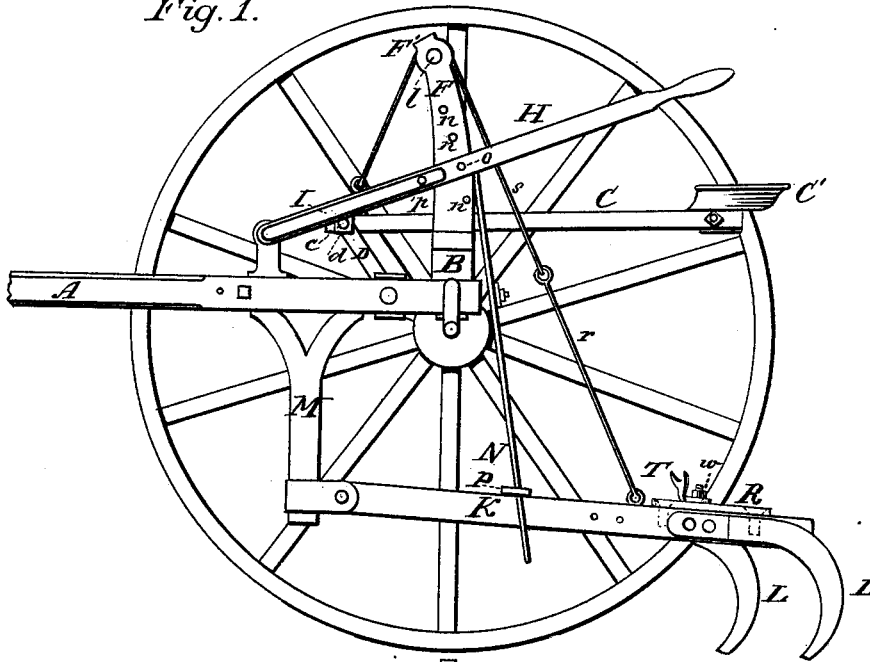
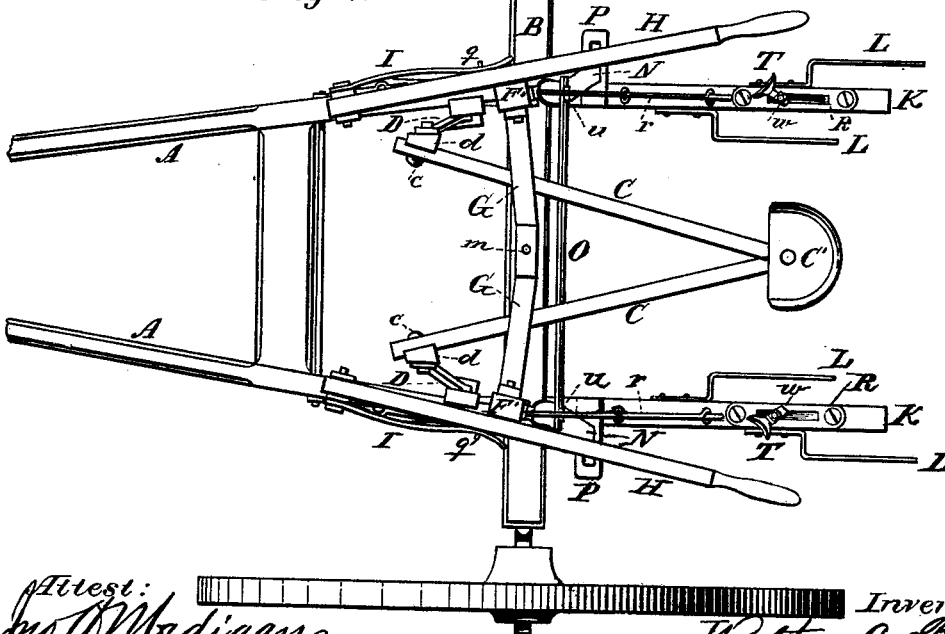

Fig. 2.



Attest:
Geo. W. Madigan
Geo. P. Brooks.

Inventor:
Walter G. Barnes
by Louis Rogger & Co.
his Attorneys

W. G. BARNES.
Riding-Cultivator.

No. 206,763.

Patented Aug. 6, 1878.

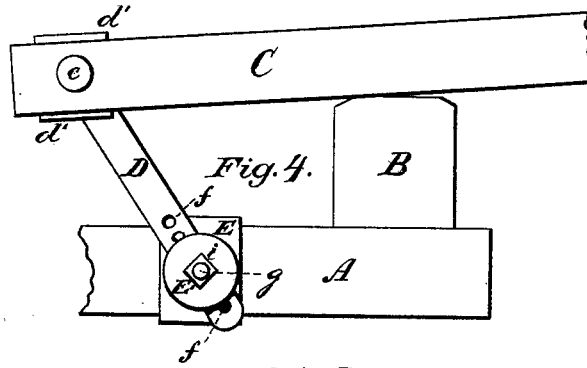
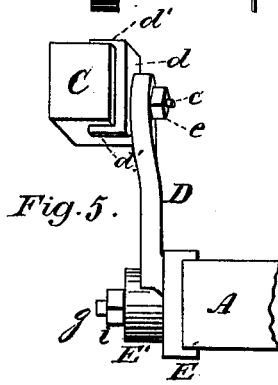
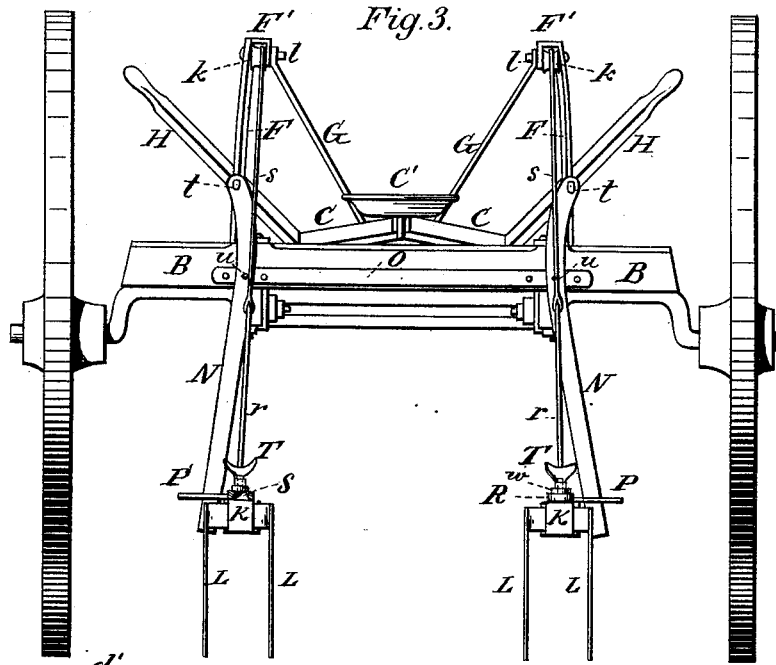
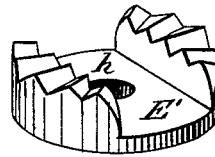
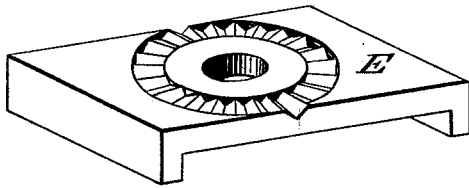

Fig. 6.

Fig. 7.



Attest:
Jno. A. Madigan
Jno. P. Brooks.

Inventor:
Walter G. Barnes,
by Louis Baggett & Co.
his Attorney.

UNITED STATES PATENT OFFICE.

WALTER G. BARNES, OF FREEPORT, ILLINOIS.

IMPROVEMENT IN RIDING-CULTIVATORS.

Specification forming part of Letters Patent No. **206,763**, dated August 6, 1878; application filed February 28, 1878.

To all whom it may concern:

Be it known that I, WALTER G. BARNES, of Freeport, in the county of Stephenson and State of Illinois, have invented certain new and useful Improvements in Riding-Cultivators; and I do hereby declare that the following is a full, clear, and exact description thereof, which will enable others skilled in the art to which it appertains to make and use the same, reference being had to the accompanying drawings, which form a part of this specification, and in which—

Figure 1 is a side elevation, one of the wheels having been removed to better show the construction and combination of parts. Fig. 2 is a top plan. Fig. 3 is a rear elevation. Fig. 4 is a detail side view of the rose and link for adjusting the seat-bars and seat. Fig. 5 is a detail rear view of the same; and Figs. 6 and 7 are perspective views of the rose-plates for securing the seat-bar link or crank in any given position.

Similar letters of reference indicate corresponding parts in all the figures.

My invention relates to riding corn-cultivators; and consists in an improved construction, arrangement, and combination of parts, substantially as hereinafter more fully described, and pointed out in the claims.

In the two sheets of drawings hereto annexed, A is the tongue, which is of a V shape, as usual in this class of cultivators, and is bolted or otherwise firmly secured to the under side of the axle B. C C are the seat-bars, which rest loosely upon the axle, and have secured, at the point where they converge, the seat C'. The front ends of each of the seat-bars C C are perforated to admit of the insertion of a bolt, *c*; and *d d* are two wedge-shaped castings, each of which is provided with side flanges *d' d'*, which project over beam C, one on each side thereof, as shown more clearly in Fig. 5, so as to hold this casting firmly in position on the beam. Bolt *c* passes through a perforation in this wedge-shaped piece *d*, and also through a hole in the connecting link or arm D, which is secured on the outer side of the wedge-plate *d* by the nut *e*.

The lower end of link D, which is provided with a series of bolt-holes, *f f f*, is inserted

between the rose-plates E and E', the construction of which will be readily understood by reference to Figs. 6 and 7, which show these two plates detached from each other. The inner plate, E, is provided with flanges like the wedge-plate *d*, for receiving the tongue-beam A, to the inner rear end of which it is secured by a bolt, *g*, one on each beam. The contiguous face of the outer plate, E', has a recess or depression, *h*, of a width and depth corresponding to the width and thickness of link D, so that the lower perforated end of this link or arm will rest completely within said recess, thus allowing the notched flanges of plate E' to come in direct contact with and fit into the notches of the inner rose-plate, E. By loosening the thumb-nut *i* of bolt *g*, plate E' may be adjusted in its relation to plate E; and it follows that when arm D is inserted into recess *h* the angle or pitch of this arm, in its relation to beams C and the tongue A, may be adjusted or regulated at will, and the arm secured in any given position by tightening the thumb-nut *i*.

There are, of course, two pairs of rose-plates, E E', two links, D D, and two wedge-plates, *d d*, one on each side, or for each of the beams of tongue A; but as both of these sets are constructed and operate precisely alike, the description of one will suffice, and from the foregoing the operation of this part of my invention will be readily understood.

To throw the seat forward and upward, which it is desirable to do when a grown person is riding the cultivator—for the purpose of balancing the tongue more evenly and also raising the seat a proper distance from the beams to allow the operator a better and easier motion of his legs in operating the beams and shovels—thumb-nut *i* is loosened, and arm D, with plate E', is turned in a forward direction. (To the left in the drawings.)

To lower the seat and throw it farther back of the axle, as when a boy is riding and manipulating the machine, arms D and plates E' are turned in the opposite direction, or to the rear of the machine. This adjustment may be further facilitated by means of the perforations *f* and bolts *g*, which admit of lengthening and shortening of arms D, and, consequently, lowering or raising the seat.

F F are curved standards secured upon axle B, one on each side. The upper part of each of these standards is bent or doubled so as to form a cap, F', into which is inserted a sheave, *k*, pivoted on a bolt, *l*. To the inner ends of the sheave-caps F', and secured thereto by the nuts on the pivot-bolts *l*, which project out through the caps, are affixed the ends of a V-shaped brace, G, the lower end or middle of which is secured upon the middle of the axle by a bolt, *m*. Uprights F have each a series of perforations, *u u u*, to receive a pin, *o*, one of which projects from the inner face of each of the handles H H, pivoted on tongue A, and the handles are forced against the standards F by springs I I, which throw pins *o* into the holes of said standards, so that the handles by which the beams and shovels may be raised or lowered may be operated and adjusted in any given position independent of each other. To keep springs I in position, they may either be provided with a perforation, *p*, near the rear end, through which passes a pin, *q*, inserted into the outer face of each handle, or they may be passed through a staple or keeper on the handle, which will answer the same purpose, viz., retain springs I in their proper positions upon the handles.

The beams K K, carrying the shovels L, are pivoted at the ends of downward-projecting brackets M in the usual manner, and may be raised or lowered by rods *r r*, which connect with chains *s s* passing over the sheaves *k* and down to the handles, to which they are secured. It follows that by depressing the handles the beams and shovels are raised or elevated, while by raising the handles and adjusting them in one of the upper holes in the standards, in the manner described, the beams are lowered.

In order to keep the beams at the proper distance from each other, as well as to regulate this distance, I employ the sway-bars N N, each of which consists of a flat bar, curved slightly at its top, where it is perforated and hung upon a hook or staple, *t*, projecting from the standard F. These sway-bars are united by a cross-bar, O, provided with a series of perforations at each end, through which pass the pins or bolts *u u* by which the cross-bar O is secured upon the sway-bars. The lower ends of these are inserted through keepers P P secured upon the beams, so that the sway-bars will not interfere with the free up-and-down motion of the beams. The distance between the beams may be regulated by adjusting the bolts *u u* in the holes in the ends of cross-bar O, and the sway-bars being hung upon the hooks *t t*, will in nowise obstruct the free lateral motion of the beams and shovels.

Upon the top of each of the beams K K, near the rear end, is secured by bolts, screws, or in any other suitable manner, a slotted plate, R, in which slides the dovetailed head S of the adjustable foot piece T, which may be secured in any given position upon plate R by tightening down the jam-nut *w*. Instead of dovetailing the slot in plate R, as in Fig. 3, the top of the beam under the plate may be provided with a groove or recess to accommodate the sliding head S. By this arrangement the foot pieces T T may be adjusted upon their respective beams by moving them forward or back, as occasion may require, to fit a long-legged or short-legged person riding the cultivator, or they may be adjusted with reference to the seat, according to whether this is thrown forward or back, so that the foot-pieces shall always be within convenient reach of the driver's feet.

Having thus described my invention, I claim and desire to secure by Letters Patent of the United States—

1. As an improvement in riding-cultivators, the combination of the tongue A, having adjustable rose-plates E E', E E' connecting-arms D D, and pivoted converging seat-bars C C carrying the seat C', whereby the throw and elevation of the seat may both be regulated, substantially as and for the purpose herein shown and described.

2. The combination, with the flanged rose-plates E E, of the arms D D, having perforations *f*, bolts *g g*, rose-plates E' E', having recesses *h h* and thumb-nuts *i i*, substantially as and for the purpose herein shown and set forth.

3. The combination of the adjustable arms D D, flanged wedge-plates *d d*, bolts *c c*, and pivoted converging seat-arms C C, substantially as and for the purpose hereinbefore set forth.

4. The combination of the pivoted cultivator-beams K K, having keepers P P, hinged sway-bars N N, perforated cross-bar O, and adjusting-bolts *u u*, substantially as and for the purpose herein shown and described.

5. The combination of the slotted plates R, adjustable foot-pieces T having heads S, and jam-nuts *w*, substantially as and for the purpose herein shown and described.

In testimony that I claim the foregoing as my own I have hereto affixed my signature in presence of two witnesses.

WALTER G. BARNES.

Witnesses:

WILLIAM BARNES,
ALLEN D. BACON.