

S. J. BAIRD.
Button-Hole Attachment for Sewing-Machine.

No. 206,768. Patented Aug. 6, 1878.

Fig 1.

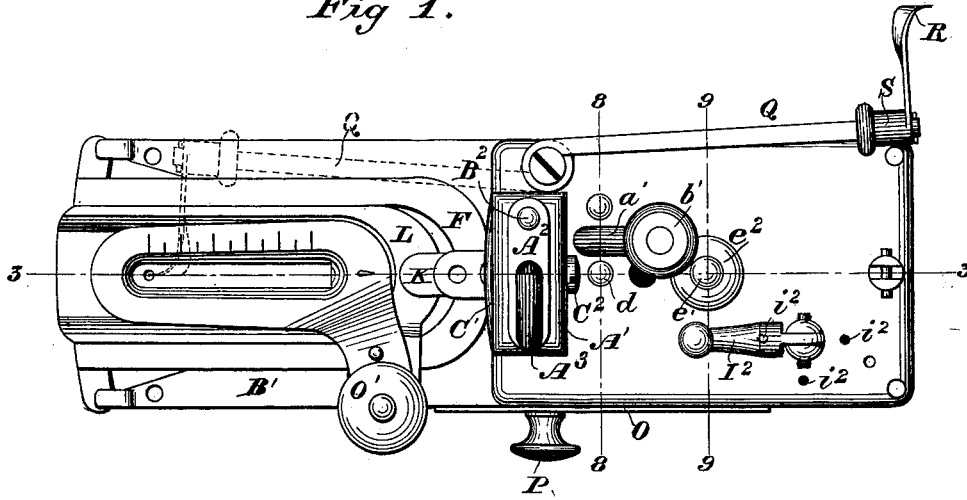
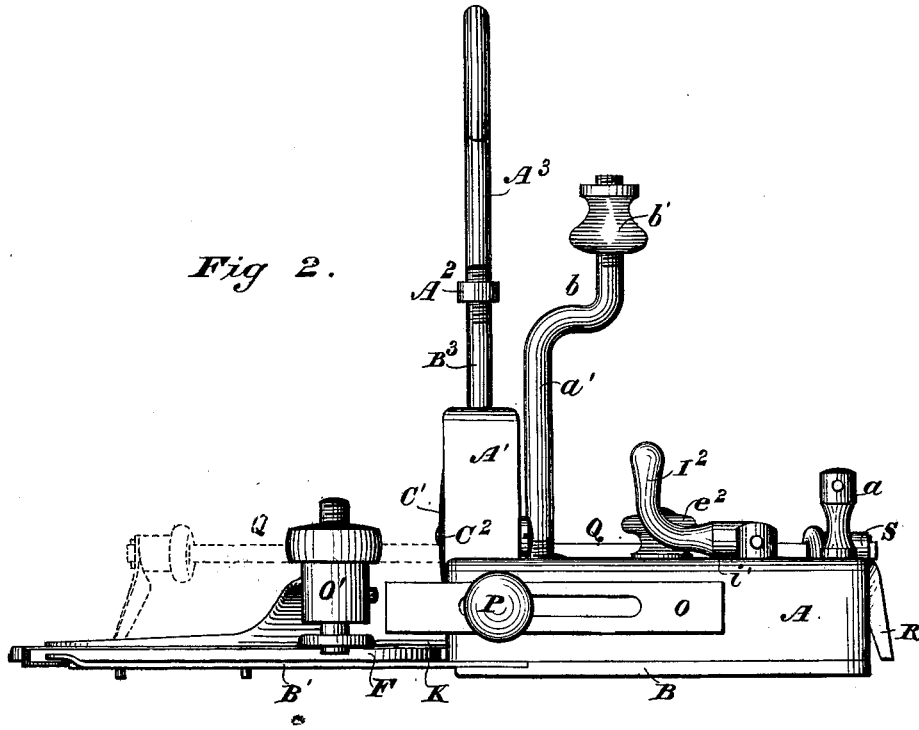

Fig 2.



WITNESSES

Geo W. Breck,
Jas a Skinkle

INVENTOR

Samuel. J. Baird.

By his Attorneys

Baldern, Hopkins & Taylor.

S. J. BAIRD.
 Button-Hole Attachment for Sewing-Machine.
 No. 206,768. Patented Aug. 6, 1878.

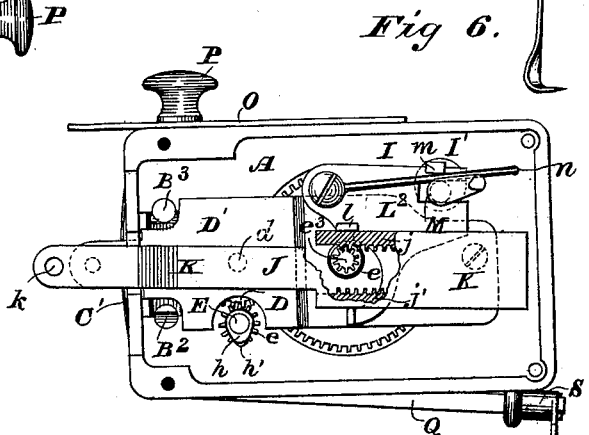
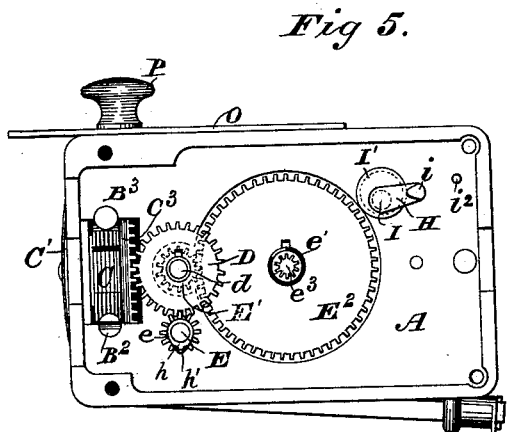
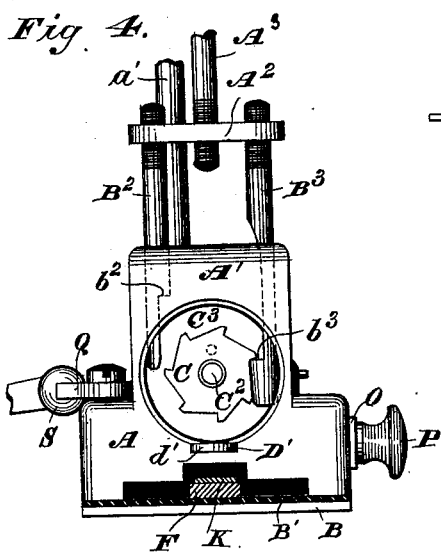
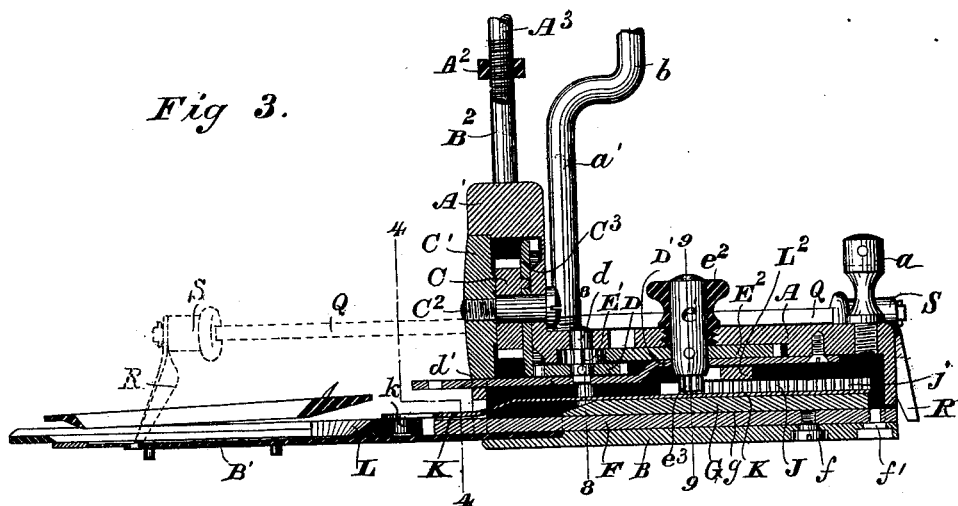

WITNESSES
Wm A Skinkle
Geo. W. Breck

INVENTOR
Samuel J. Baird.
 By his Attorneys
Paldwin, Hopkins & Taylor.

S. J. BAIRD.
Button-Hole Attachment for Sewing-Machine.

No. 206,768.

Patented Aug. 6, 1878.

Fig 7.

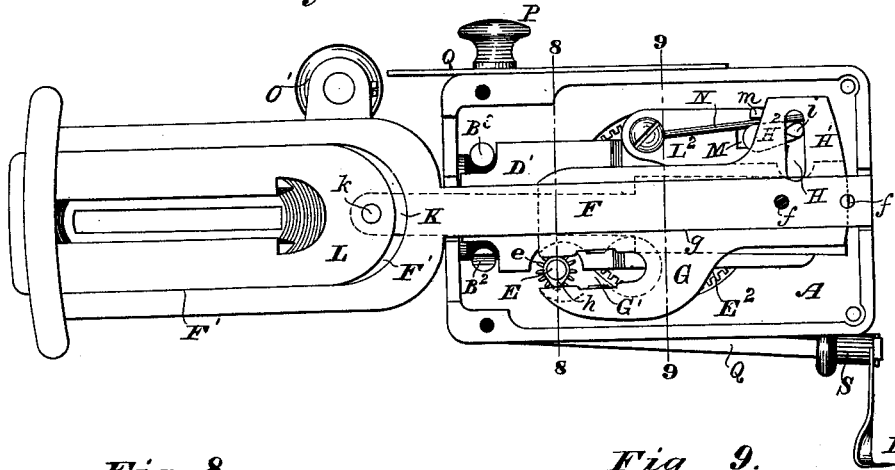

Fig 8.

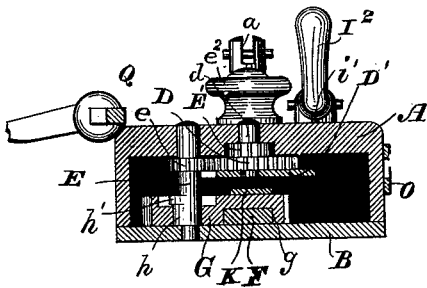

Fig 9.

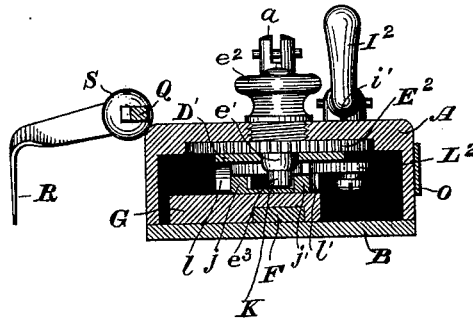

Fig 10.

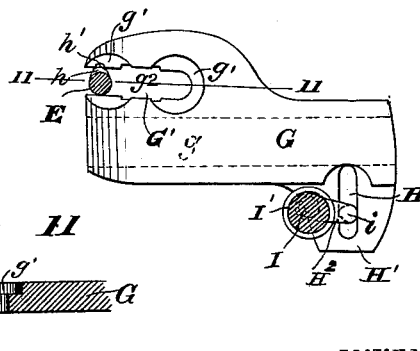

Fig 11.



WITNESSES

Wm A Skinkle
Geo. W. Breck.

INVENTOR

Samuel J. Baird.

By his Attorneys

Baldwin, Hopkins & Taylor.

UNITED STATES PATENT OFFICE.

SAMUEL J. BAIRD, OF RICHMOND, VIRGINIA, ASSIGNOR TO GEORGE TRULL,
OF NEW YORK, N. Y.

IMPROVEMENT IN BUTTON-HOLE ATTACHMENTS FOR SEWING-MACHINES.

Specification forming part of Letters Patent No. **206,768**, dated August 6, 1878; application filed
May 1, 1878.

To all whom it may concern:

Be it known that I, SAMUEL J. BAIRD, of Richmond, in the county of Henrico and State of Virginia, have invented certain new and useful Improvements in Button-Hole Attachments for Sewing-Machines, of which the following is a specification:

My invention relates to improvements in button-hole attachments of the same class as those shown and described in sundry Letters Patent of the United States heretofore granted me, my present invention resembling, more or less, in general features of construction and mode of operation, the inventions shown in such patents, among which may be mentioned Reissue No. 4,794, of March 12, 1872; No. 117,364, of July 25, 1871; Nos. 134,346 and 134,347, of December 31, 1872, and No. 159,740, of February 16, 1875.

My improvements consist in novel organizations of parts and certain combinations of devices hereinafter first fully described, and then specifically designated by the claims.

In the accompanying drawings, Figure 1 is a plan or top view of a button-hole attachment embodying all my improvements; Fig. 2, a side elevation of the same; Fig. 3, a longitudinal vertical section on the line 3 3 of Fig. 1. Fig. 4 is a transverse vertical section on the line 4 4 of Fig. 3, the ratchet securing and covering plate or face-disk of the turret or ratchet chamber being removed. Fig. 5 is a bottom view, showing the gearing, with the base-plate, rack-bar, and other parts detached; Fig. 6, a view similar to Fig. 5, with some of the devices that are not shown by Fig. 5 in place, and partly broken away. Fig. 7 is a bottom view of the entire attachment except the base-plate. Fig. 8 is a vertical transverse section on the line 8 8 of Figs. 1, 3, and 7; Fig. 9, a similar section on the line 9 9, of Figs. 1, 3, and 7. Fig. 10 is a plan or top view of the shifting or oscillating cam for changing the direction of the feed of the fabric and presenting a different side of the button-hole to the needle of the machine; Fig. 11, a section on the line 11 11 of Fig. 10.

The gearing is inclosed and entirely protected in a box or casing, A, and its vertical

chamber or turret A¹, all, by preference, cast together to form an open-bottomed covering or boxing to which the base-plate B is secured by screws, with the extension or cloth-clamp supporting base-plate B¹. The vertically-projecting chamber or turret is tapped or drilled through its top wall to form two parallel holes serving as bearings and guideways for two round reciprocating driving rods or shafts, B² B³, connected at or near their tops by a cross-bar or connecting-piece, A², provided with screw-taps into which the rods screw at their threaded ends. This cross-bar is connected adjustably with the lower end of a vertical hooked rod, A³. The screw-thread on the rod fits a corresponding tap or female screw in the cross-bar. In this way the connection between the driving-rods and vibrating needle-arm or equivalent part of the sewing-machine may be lengthened or shortened to suit the attachment to the machine with which it is to be used. The hooked end of the connecting-rod A³ is either adjusted directly to the needle-bar or vibrating arm, or to a lever pivoted to a post, a, upon the rear end of the casing A. When such a lever is used it extends forward, is connected intermediate its ends to the said connecting-rod, and then jointed to the needle-bar, as explained in one of my prior patents. A turning upright or brace rod, a', screwed into the casing top at its lower end and bent or cranked at its upper end, b, has an adjustable head or nut, b', at top, by which to adjust the attachment and firmly hold it upon the bed of the machine. This brace, being properly adjusted, is caused to clamp or press the attachment to the bed of the machine by adjusting the screw-nut upward against the overhanging stationary arm of the machine.

Within the turret or vertically-projecting portion A¹ of the casing is secured a ratchet-wheel, C, the teeth of which are alternately engaged by lugs or shoulders b² b³, with which the reciprocating driving-rods B² and B³ are respectively provided. At each complete reciprocation or advance and return stroke the ratchet is twice partially rotated, the shoulder b² moving it round one tooth upon the down-stroke, and the shoulder b³ moving it round

another tooth upon the upstroke. There are short intervals of rest between the movements of the ratchets, so as not to interfere with the operation of the needle and proper stitching of the button-hole. The ratchet-wheel rotates vertically in one direction only, and in an unchanging or fixed plane, the same as that of the reciprocation of the driving-shafts. The shoulders $b^2 b^3$ project inwardly from the shafts, and likewise reciprocate at all times in the plane of revolution of the ratchet, so as properly to act upon the teeth.

A covering-plate or securing-disk, C^1 , upon the face or front of the ratchet-chamber or turret A^1 , is detachably secured in place by a screw, C^2 , which serves also as the shaft or bearing for the ratchet, and a crown-wheel, C^3 , formed with or connected to the ratchet-wheel so as to turn with it. This crown-wheel meshes with and operates a main spur-gear or master wheel, D , revolving with its shaft d , which is supported at its opposite ends in the casing top and in a bent arm or plate, D' . This plate is secured at its rear end by a screw to the under side of the casing top, and is supported at its front end in a rest or slot, d' , in the front wall or face of the casing. The master-wheel D revolves a small pinion, e , and a cam-shaft, E , on which it is fastened, as will hereinafter be explained, and also imparts motion to a small pinion, E^1 , fast on the shaft d , above the master-wheel. The pinion E^1 meshes with and drives a larger pinion, E^2 , fast on a shaft, e^1 . This great pinion E^2 is supported on the straight highest portion of the plate D' , which is bent downward and then extended parallel with its upper portion, to support the shaft d of the master-pinion, as before described. To steady the great pinion-shaft e^1 it is mounted in a long bushing or sleeve-bearing formed by a thumb-nut, e^2 , screwed into the casing top. At its lower end this shaft carries a small pinion, e^3 , engaging with either one of two racks, as will hereinafter be explained, to feed the fabric in either direction desired.

A horizontally oscillating or vibrating arm or lever is composed of a plate, F , in a suitable guideway, F' , in the front end of which the cloth-clamp or fabric-holder reciprocates endwise, and by which the said clamp is also laterally reciprocated or intermittingly moved to and fro transversely to the lines of stitching, for a well-known purpose. This oscillating lever is pivoted at f or f' , near its heel or extreme rear end. By pivoting at f a greater lateral movement is given the cloth-clamp (which is operated as presently to be explained) than would be imparted were the pivot f' used. The adjustment of the lever-pivot enables the attachment to be suited to different goods and varying sizes of button-holes. The adjusting-holes in the base-plate and lever may be increased, if desired, to admit of still greater variation in the work.

The lever F fits in a socket, groove, or trough-like recess, g , in the under side of a cam-frame or shifting-plate, G , so as to par-

take of the movements imparted to this plate, which rests upon the casing bottom or base-plate B . The cam-shaft E , before referred to, passes through a slightly-inclined cam-slot, G' , (see particularly Fig. 10,) at the forward end and near one side of the shifting-plate or cam-frame. Were the slot exactly parallel with the longitudinal center or recess g of the frame it would not be acted on by the wiper-shaft I to shift the cloth-clamp, as hereinafter fully explained. This slot, at or about midway its length, is made of a width, from the top to the bottom of the plate, less than the width of the slot, for a portion of the thickness of the plate at its ends. By reference to Figs. 10 and 11 it will be seen that the slot is widened by recesses $g^1 g^1$ at each side of the narrow portion g^2 , and that the width of this central portion g^2 is also slightly increased from the plane or level of the recess bases to the bottom of the plate. There are two cams or wipers on the cam-shaft, the one, h , to act upon the walls of the narrow portions of the slot at its ends or on either side of its middle, and moving clear of the slot-walls when the shaft is at the middle or narrow top part of the slot; and the other, h' , to act upon the slot-walls at the middle slightly-widened top part, and moving clear of them when the shaft is revolved at either end of the slot, so as to cause this cam h' to move in the cut-away or recessed parts of the slot. The bottom narrow portion of the slot may be of the same width throughout, instead of being slightly widened beneath the narrow top part, which is slightly wider than the bottom ends of the slot, so as to accommodate the long wiper h' , as shown by the drawings. Such slight change in the formation of the slot would make no difference in the operation.

At or near the rear end the cam or shifting-plate has a transverse slot, H , on that side of its longitudinal center opposite the side in which the longitudinal slot G' is made. This slot H is shown as formed mainly in a shoulder or lateral lug, H^1 , on the plate, and as extending entirely through it. A pin or lug, i , on a crank-arm, H^2 , of a short shaft, I , secured eccentrically upon a crank-wheel or disk, I^1 , attached to a stud which projects through the top of the casing, is turned by a pivoted handle or bent controlling-lever, I^2 , which is provided with a stop pin or lug, i^1 , which can be caused to engage with any one of three holes, i^2 , in the casing-plate. As will hereinafter be fully explained, when this lever is locked in the position shown by Figs. 1 and 2 of the drawings, the cloth-clamp is being moved outward or away from the casing. When it is turned one-quarter round, so as to project laterally from the casing, the endwise movement of the clamp is stopped, and longer stitches, to "cross-lock" or strengthen the ends of the button-holes, are made; and when the lever is given another quarter-turn, so as to project to the rear or opposite to the direction in which it stands in Figs. 1 and 2, the cloth-

clamp is being moved inward or toward the casing.

The lateral or oscillating movement of the cloth-clamp is produced by the action of the ratchet-attached crown-wheel C^3 , the master-wheel D , pinion e , shaft E , and cams or wipers h h' . When the cam-frame or shifting-plate G is moved endwise, so as to bring the short wiper into action at either end of the slot G^1 , short vibrating movements are given, and when the longer wiper, h' , is acting the lateral throw is increased.

As the cam-shaft pinion is given a quarter-turn at each downward and at each upward stroke of the driving-shafts, it will be seen that at each complete revolution the cloth-clamp is given a complete vibration or to-and-fro lateral movement, for at one movement of the cam-shaft the cloth-clamp is moved in one direction, at the next movement of the shaft the clamp is undisturbed, while the succeeding quarter-turn gives the return-movement of the clamp, which then remains at rest during the next movement of the cam, and so on.

The endwise reciprocation or movement of the cloth-clamp lengthwise the button-hole is given through or by way of the pinions E^1 , E^2 , and e^3 , and a double rack, J . The teeth of this rack are formed upon the inner sides of parallel ribs or flanges j j' , equidistant from the longitudinal center of a bar or plate, K .

The double rack is formed upon the heel end and top surface of this plate, and the plate rests at its bottom upon the top of the cam-frame G , so that it may move laterally and longitudinally thereon.

At its front end the plate K projects through an opening in the casing, and is provided with a pin or catch, k , which engages the bottom plate or lower section L of the cloth-clamp, which slides in the guideway of the oscillating bar F .

The plate K , at its outer end, is bent downward, and is made springy, so as to bear with a yielding pressure upon the cloth-clamp to admit of its ready connection with and separation from the clamp, and yet prevent accidental displacement. The rack J or heel end of this plate is fitted snugly, but so as to be capable of sliding freely endwise between short downwardly-projecting guide-posts or lugs l l' on a regulating-plate or rack-adjusting frame, L^2 . This rack-regulator is supported at top against the plate D^1 , and is slotted at M , near one side and at its rear end. A lug, m , projects downwardly from the plate at its outer edge, and close to the slot and near its heel.

The eccentric-shaft I projects through the slot M . This shaft is operated by the vertically-rocking turning-handle or controlling-lever I^2 , as before explained.

The regulating-plate or rack-adjusting frame L^2 is secured at its front end and near its outer edge, about in line with its slot, to a springy arm or wire rod, N . This yielding rod is bent upwardly at its rear end n , and fitted so as to turn in a hole in the top of the casing. The

rod, it will be seen, passes between the cam-shaft I and lug m , and fits snugly between them. By this construction, when the plate L^2 is oscillated about its pivot n so as to bring either the rack-bar j or the rack-bar j' into gear with the pinion e^3 , and present the unworked side of a button-hole to the needle, the amount of movement or throw of the plate is sufficient to slightly strain the rod N between the shaft I and lug m , and keep the rack and pinion in gear by the pressure of the rod, the tendency of which is to move the plate farther than is necessary to bring the rack and pinion together. Thus accidental slip or disengagement of the pinion and rack is prevented.

From the above description it will be seen that when the pinion engages the toothed bar or part j of the rack, the cloth-clamp is fed outward, and when the rack j' is engaged the reverse or inward feed takes place. The rack is held in either position by the lever I^2 . When the lever is turned to and secured in the intermediate position the rack is disengaged from the driving-pinion e^3 , and the end stitching takes place, as before explained.

The one rod N , it will be seen, serves to pivot the plate L^2 and hold it in the proper position when the racks are engaged by the pinion.

The single handle or turning lever I^2 and its attachments or connections serve to give all the required adjustments to the cam-frame or shifting-plate G and the regulating plate or rack-shifting frame L^2 . In shifting the cloth-clamp from one side to the other of a button-hole by swaying or vibrating the lever F on its heel-pivot, and in working the ends of the holes before so shifting the clamp, the operation (which will best be understood by glancing at Figs. 1 and 2, and particularly referring to Figs. 7, 8, 9, and 10) is as follows: One side of the button-hole having been stitched, the handle is disengaged from the forward catch or hole i^2 , Fig. 1, and given a quarter-turn to bring its stop to the side hole. The result of this movement is to disengage the pinion e^3 and the toothed rib or side j of the double rack-bar J , and leave the pinion clear of both sides of the rack, thus stopping endwise movement of the clamp. At the same time the plate G is shifted forward half its endwise movement by the action of the pin i in the slot H , and the long wiper h' comes into action, as before fully explained. The disengaging of the rack-operating pinion simultaneously, or nearly so, with the throwing out of action of the wiper h and starting into operation of the wiper h' , is due to the sidewise movement of the spring-rod N , carrying with it the plate or rack-shifting frame L^2 , and also the rack-bar J . This bar being embraced by the lugs l l' , Figs. 9 and 6, of the frame L^2 is forced to partake of its lateral movements. The movement of the walls of the inclined slot G^1 , in contact with the shaft E , as the frame G is moved endwise, causes the frame to vibrate slightly on the pin

z, and this sidewise movement is imparted to the lever F, which is thus caused to sway to the extent of half of its sidewise throw on its heel-pivot. After securing the end of the button-hole the handle P is given another quarter-turn and brought to engage the rear hole, z'. This movement throws the pinion c' into gear with the side or toothed rib j' of the double rack opposite to that before engaged, and simultaneously completes the lateral movement or sway of the lever F by the action of the shaft E in the slot of the cam-frame, and the return movement of the clamp takes place to work the remaining side of the button-hole, preparatory to locking its end, by turning the handle in the reverse direction, as will readily be understood.

A slotted slide, O, adjustable by a thumb-nut or set-screw, P, upon the side of the casing A, in line with the hub or securing-sleeve O' of the cloth-clamp, serves to gage the length of the button-holes. Upon its inward or return movement the operator adjusts the rack before the clamp strikes the gage, and the reciprocating clamp would be dogged by this gage, and the machine stopped, should the operator be inattentive.

A swinging arm, Q, is pivoted at one end upon the top front corner of the case, and the opposite side of the turret A' to the slide or gage O. This arm is provided with a curved knife, R, on a sliding collar, S, free to be moved along the rod. This knife may be swung around out of the way at the rear of the casing when desired, and when in operation it projects through the slotted cloth-clamp and through the fabric, so as to cut the button-hole by sliding the knife along its horizontally-swinging arm, either before or after the stitching of the button-hole. The knife-arm is made sufficiently springy to yield enough to allow the operator to place the knife in the slotted clamp, so that the cut may be made in the longitudinal central line of the button-hole by moving the knife by the hand along its supporting and guiding rod Q.

As hereinbefore stated, my present improvements resemble closely in some respects, and in others are substantially similar to, some of my previous inventions; but I have cheapened and simplified the attachment in construction, and attained greater accuracy and more perfect operation.

I claim as of my own invention—

1. The combination of the chambered turret, the single ratchet-wheel inclosed therein, the crown-wheel also inclosed in the turret, the screw-shaft on which the ratchet-wheel and crown-wheel are mounted in contact with each other, and the covering-plate closing the opening into the turret and confining the ratchet and crown-wheel therein, all substantially as hereinbefore set forth, whereby the parts are protected, confined in a small space, and may readily be removed.

2. The combination of the turret, the ratchet-wheel, the driving-shafts, the adjustable cross-bar connecting the driving-shafts, and the rod adjustably connected with said bar, substantially as and for the purposes specified.

3. The combination of the casing having a chambered turret, the reciprocating driving-shafts, the single ratchet-wheel, the vertically-rotating crown-wheel connected to the ratchet and inclosed with it in the turret, the horizontal master-wheel engaging with the crown-wheel beneath the casing top and at the base of the turret, the vertical cam-shaft E, and its pinion driven directly by the master-wheel, substantially as and for the purpose described.

4. The combination, substantially as hereinbefore set forth, of the intermittingly-operated ratchet-wheel, the crown-wheel, the master-wheel driven thereby, the cam-shaft E, its pinion, the cloth-clamp-oscillating lever pivoted at its heel, and its cam-frame or shifting-plate provided with a slot in which the two wipers of the cam-shaft operate, in the manner specified.

5. The combination, substantially as hereinbefore set forth, of the cloth-clamp-oscillating lever pivoted at its heel, the cam-frame or shifting-plate having the inclined slot G' in its front end, the cam-shaft E, working in said slot and provided with the wipers h h', the adjusting-handle or turning-lever interlocking with the casing top, and its crank-arm and pin engaging the slot in the rear end of the shifting-plate.

6. The combination of the oscillating lever F, pivoted at its heel, the reciprocating cloth-clamp, the double-racked plate, the rack-engaging pinion, the rack-adjusting frame L', the cam-frame or shifting-plate by which the lever F is oscillated, and the handle or turning lever operating both the said cam-frame and the adjusting-frame, these members being constructed and operating substantially as hereinbefore set forth.

7. The combination, substantially as hereinbefore set forth, of the double-racked bar, its adjusting-frame slotted at the rear, the crank working in said slot, the bent rod connected to said frame at front and turning in the casing, and the lug on the heel of the frame between which and the crank the rod passes.

8. The combination of the master-wheel, the pinion on its shaft, the great pinion driven thereby, the rack-pinion, and the laterally-adjustable rack-bar, substantially as and for the purposes specified.

In testimony whereof I have hereunto subscribed my name.

SAMUEL J. BAIRD.

Witnesses:

WM. P. MAYO,
JAS. MILLER.