

W. STEVENS.
 Hatchway-Door Mechanism.
 No. 206,842. Patented Aug. 6, 1878.

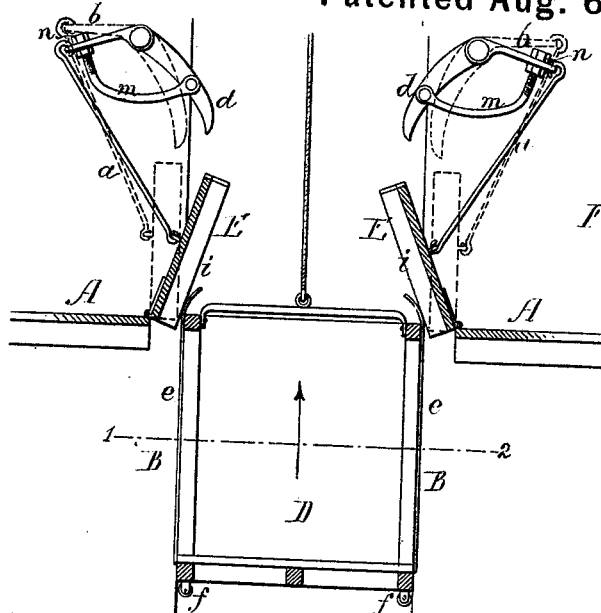

FIG. 1.

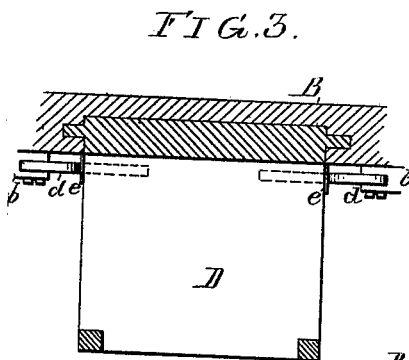

FIG. 3.

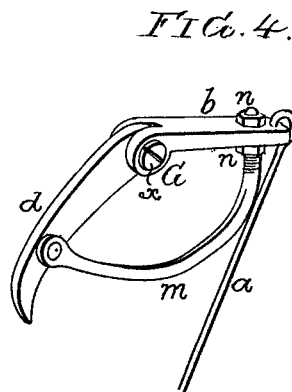

FIG. 4.

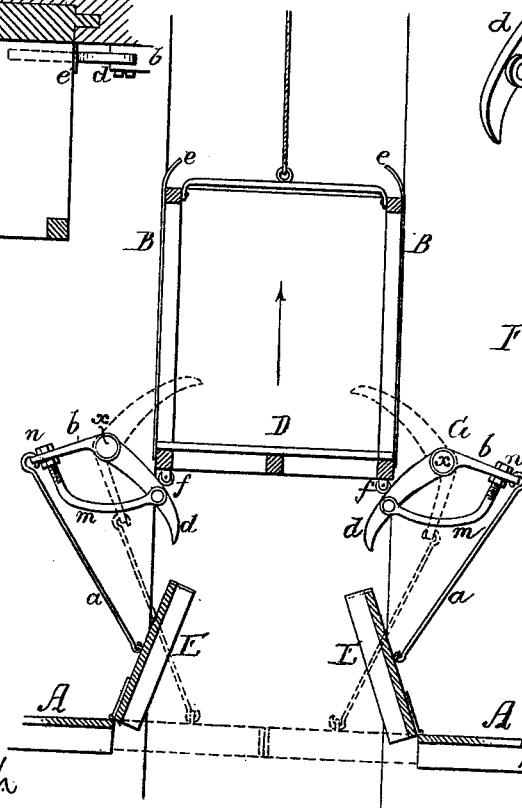

FIG. 2.

Witnesses,
 Harry Smith
 Thomas W. Swan

Inventor,
 William Stevens
 by his Attorneys
 Howard Hon

UNITED STATES PATENT OFFICE.

WILLIAM STEVENS, OF PHILADELPHIA, PENNSYLVANIA, ASSIGNOR OF ONE-HALF HIS RIGHT TO ISAAC RICHARDS, OF SAME PLACE.

IMPROVEMENT IN HATCHWAY-DOOR MECHANISMS.

Specification forming part of Letters Patent No. 206,842, dated August 6, 1878; application filed April 23, 1878.

To all whom it may concern:

Be it known that I, WILLIAM STEVENS, of Philadelphia, Pennsylvania, have invented a new and useful Improvement in Hoisting Apparatus, of which the following is a specification:

The object of my invention is to construct a cheap, simple, and effective device, whereby the ascending or descending cage of a hoisting apparatus is caused to automatically open and close the hatch-covers. This object I attain in the manner which I will now proceed to describe, reference being had to the accompanying drawings, in which—

Figures 1 and 2 are views in different positions, showing the application of my improvement to a back-guided hoisting apparatus; Fig. 3, a sectional plan on the line 1 2, Fig. 1; and Fig. 4 a perspective view of part of my invention.

A represents one of the floors of a building, and B the frame-work in which the cage D slides, ribs at the back of the cage being adapted to grooves in the frame-work in the usual manner.

E E are the hatch-closing doors, each of which is connected by means of a rod, *a*, to one arm, *b*, of a bell-crank lever, G, these levers being hung to the frame B at some distance above the doors, and in such a position laterally that when the doors are down their arms *d* will project into the path of the cage D, as shown by dotted lines in Fig. 2.

On each side of the cage D is a strip of metal, *e*, the upper end of which is bent inward, as shown, and on the bottom of the cage, near each side of the same, is an anti-friction roller, *f*.

The operation of the above-described mechanism is as follows: As the cage rises the bent upper ends of the strips *e* act on the under sides of the doors E or upon ribs *i* on the same, and elevate the doors, as shown in Fig. 1, until they assume the nearly vertical position shown by dotted lines in that figure, the bell-crank levers G being so operated by the doors as they rise that when said doors are fully open the arms *d* of the levers will have been moved outward to such an extent that they will not interfere with the free upward passage of the

cage. (See dotted lines, Fig. 1.) As soon as the bottom of the cage has risen above the edges of the doors, however, the latter commence to fall, thus pulling the arms *b* of the levers G downward and throwing the arms *d* of said levers against the rollers *f* on the bottom of the cage, as shown in Fig. 2, the closing of the doors E being thus governed by the ascending cage, so that the operation of closing is a gradual and easy one, without shock or jar. Upon the descent of the cage the reverse of this operation takes place, the arms *d* of the levers G being first depressed so as to raise the arms *b* and the doors E, and the latter, as soon as the cage has passed through the hatchway, falling by their own weight, the descent being governed by the rounded upper ends of the strips *e*.

The arms *b* and *d* of the lever G are made separate from each other and hung loosely to the pivot-pin *x*, a bent bar, *m*, being secured at one end to the arm *d* and passing through an opening in the arm *b*, at which point it is threaded for the reception of two nuts, *n*, by manipulating which the positions of the arms *b* and *d* in respect to each other may be varied, so that after the parts have been fitted together the levers may be adjusted to work in exact accordance with the doors. By this means accurate fitting of the parts in the first instance is rendered unnecessary.

It will be observed, on reference to the dotted lines in Fig. 2, that when the doors E are closed the pivots *x* of the levers, the points of connection between the rods *a* and the arms *b* of the levers, and the points of connection between the rods *a* and the doors are in line with each other, and that by this means the doors E, when closed, are held in position by the levers through the medium of the rods *a*, so that no recesses or flanges around the edges of the elevator-well are necessary in order to properly support the doors.

My invention, although illustrated as applied to an elevator with back-guided cage and double doors, can be applied with equal facility to elevators in which the cage is guided at the side, or in which but a single door is used.

I am aware that numerous devices have

hitherto been adopted whereby the automatic opening and closing of hatch-covers by an ascending or descending cage has been effected, and therefore do not claim this feature broadly; but

I claim as my invention—

The combination of a cage, D, a door, E, and a bell-crank lever, G, the arms of which are adjustable in respect to each other, all substantially as specified.

In testimony whereof I have signed my name to this specification in the presence of two subscribing witnesses.

WM. STEVENS.

Witnesses:

HARRY A. CRAWFORD,
HARRY SMITH.