

F. L. BAILEY.
Machine-Gun.

No. 206,852.

Patented Aug. 13, 1878.

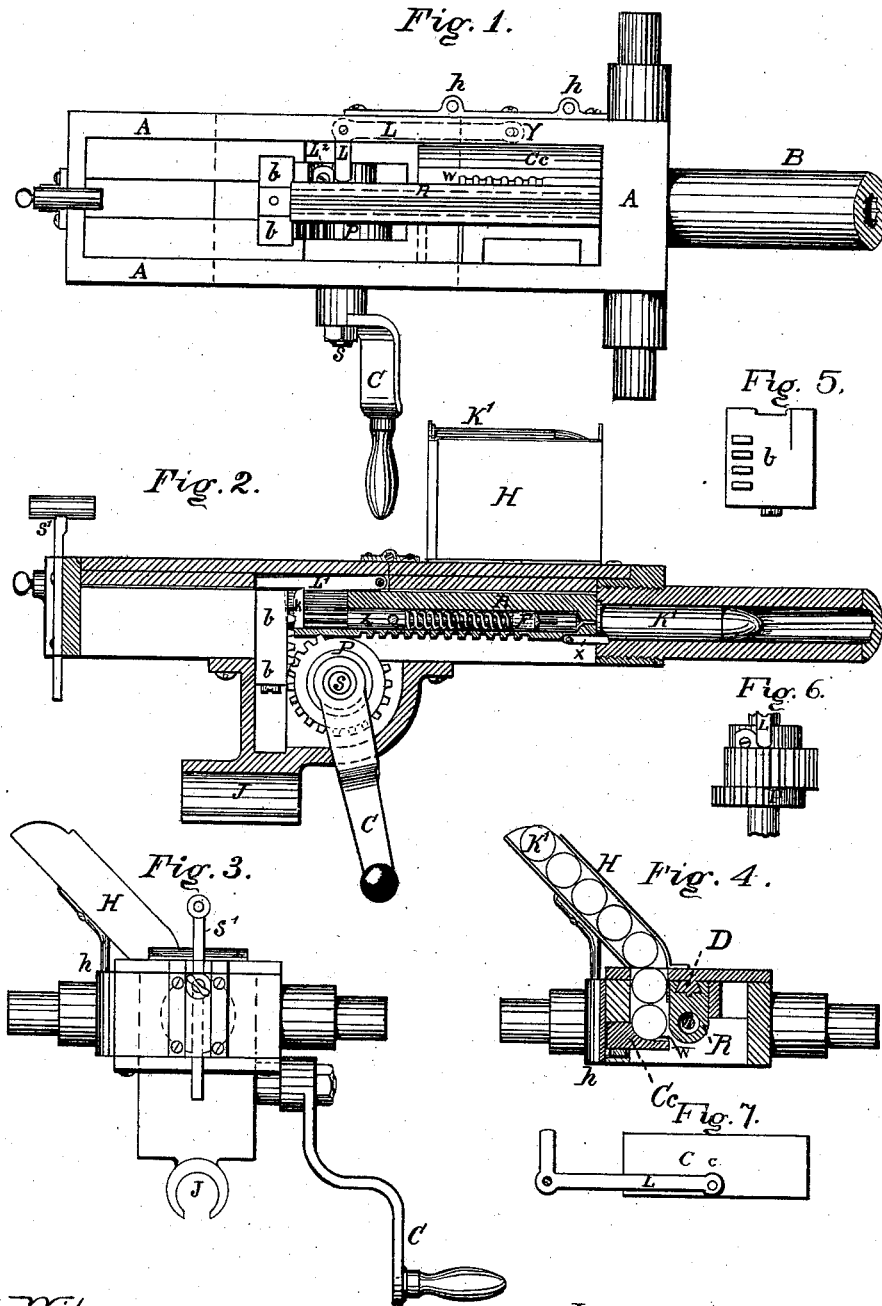

Witnesses;
C. P. Jacobs
W. V. Lippincott

Inventor;
Fortune L. Bailey

UNITED STATES PATENT OFFICE.

FORTUNE L. BAILEY, OF INDIANAPOLIS, INDIANA, ASSIGNOR TO THE
BAILEY GUN COMPANY, OF SAME PLACE.

IMPROVEMENT IN MACHINE-GUNS.

Specification forming part of Letters Patent No. 206,852, dated August 13, 1878; application filed
April 8, 1878.

To all whom it may concern:

Be it known that I, FORTUNE L. BAILEY, of Indianapolis, Indiana, have invented an Improvement in Machine-Guns, of which the following is a specification:

My object is to furnish a light, serviceable cannon capable of throwing shot, canister, or shell of any desired caliber, and so arranged in its mechanism as to be automatic in its operation, and susceptible of being loaded and fired in rapid succession, combining with strength of parts simplicity of construction and economy of cost.

The accompanying drawings will illustrate my invention, the same letters being used to represent corresponding parts.

In Figure 1, letter A represents the framework of the piece; B, the barrel, which is screwed into the frame. C is a crank attached to the shaft S, which passes through the pinion P, which has cogs part of the way round, as shown. *b b* represent the breech-block, which has cogs on the inside intercepting with the cogs of the pinion, and so made to rise or fall, according as the crank is turned one way or the other, at the proper time. L L represent an L-shaped lever, fixed at its right angle to the frame, which operates the carrier-block C c, moving it laterally out and in line with the bore of the barrel, being actuated by means of the lug L², which is fixed to the shaft S, striking alternately on either side of the lever L L. *h h* are holes for bracket-pins or supports of the hopper. Upon the edge of the carrier-block C c is a raised guard, *w*, to keep the cartridge from rolling off, and it is notched, so as to pass radially under the cogs of the rammer-block.

In Fig. 2, H is the hopper, in which the cartridge K' is placed. F is the firing-pin, which passes through a sleeve, Z. This sleeve is attached to the rammer-block R, which is cogged on the under side, so as to intermesh with the cogs of the pinion P, by the revolution of which it is moved forward and backward to perform the operation of ramming and extracting the cartridge. The extractor *x* is shown attached to the under side and forward end of the rammer-block R. *k* is a knob or head on the rear end of the firing-pin, which

interlocks with the cocking-latch L'. This cocking-latch is secured to the top of the frame-cover by a screw near its end, and the other end is free. S' is the rear sight, and J is the ball-joint socket.

In Fig. 4 is seen a view of the rear end of the rammer-block R as held in position by the dovetailed guide D, which is a projection from the under side of the cover, and extends the full length of the breech, so as to make a bearing all the way. The method of feeding the cartridges is also shown, and the manner in which they are held by the carrier-block C c. The gun can be used without any hopper at all, and in guns of the larger calibers the hopper might well be dispensed with.

The gun is operated as follows: In Fig. 2 the mechanism is shown just before the act of firing. The operator, taking hold of the crank C, gives it a slight pull toward the rear, and the cogs of the pinion P in contact with the cogs of the breech-block *b b* cause the latter to rise, and the upper end of the block strikes and lifts the end of the cocking-latch L', whereby the head or knob *k* of the firing-pin is released, and the elasticity of the spring sends the firing-pin forward, the point striking the cartridge-primer and discharging it. The extractor *x*, having passed into the barrel with the cartridge, holds on by its hook to the flange thereof.

To withdraw the empty shell from the barrel, the operator turns the crank C forward, whereby the breech-block is lowered, so that the cogs of the pinion are thrown out of gear with the cogs on the breech-block, and into gear with the cogs of the rammer-block R. This, of course, moves the rammer-block backward, and the shell is withdrawn by the hook or extractor *x*. As soon as withdrawn it drops by its own weight through the open frame to the ground.

As soon as the shell has fallen out of the way the lug L² on the shaft comes in contact, by the revolution of the crank, with the lever L L, which is attached to the carrier-block C c at the point Y, and the carrier-block is moved, with a new cartridge, over in line with the chamber of the barrel. When thus in line the movement of the crank is reversed, and the ram-

mer-block is thrown forward by the cogs, pushing the cartridge into the chamber of the barrel. By continuing the revolution of the crank the breech-block is again raised, the spring released by the cocking-latch being lifted, and the primer exploded by the firing-pin. At the same time the carrier-block C c is moved backward to its place by the reverse action of the lever L L, and is ready to receive another cartridge. Of course, my system could be extended to operate a series of barrels as well as one.

What I claim, and desire to secure by Letters Patent, is—

1. In a breech-loader, the combination of a rammer-block, a breech-block, and a pinion having a portion of its cogs removed, the two blocks being made to move alternately and at right angles to each other, substantially as shown.

2. In a breech-loader, the combination of the rammer-block R, having cogs on its under side, breech-block b, and pinion P on the operating-shaft, the breech-block having a vertical movement, so as to rise behind the rear

end of the rammer-block after it has forced the cartridge home, the two blocks being operated by the same device, substantially as shown.

3. The latch L¹, having a shoulder to catch behind the flange on the end of the firing-pin, in combination with the breech-block b, that trips the latch as it rises into position and fires the gun, substantially as specified.

4. The combination of the lever L, pivoted at its corner upon the frame A, and connected at its front end to the carrier-block C c, with the lug or cam L² on the pinion P, to strike against the short end of the lever L, substantially as described.

5. The cogged pinion P, in combination with the breech-block b b, the rammer-block R, the shaft S, and the cocking-latch L¹, substantially as and for the purposes above set forth.

In witness whereof I have hereunto set my hand this 4th day of March, A. D. 1878.

FORTUNE L. BAILEY.

Witnesses:

C. P. JACOBS,

W. V. LIPPINCOTT.