

W. CHEGWIN.  
Vehicle-Spring.

No. 206,862.

Patented Aug. 13, 1878.

*Fig. 1.*

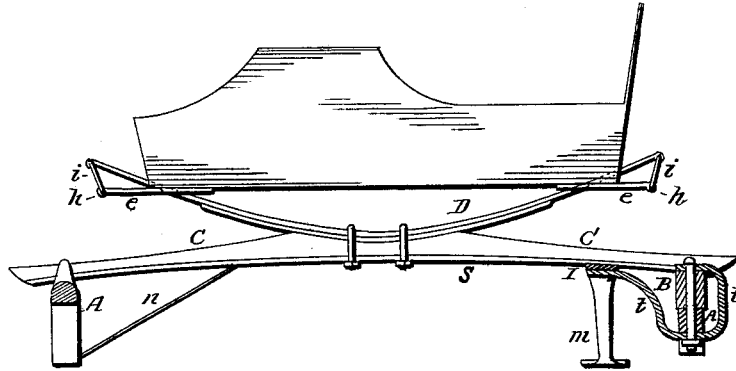

*Fig. 2.*

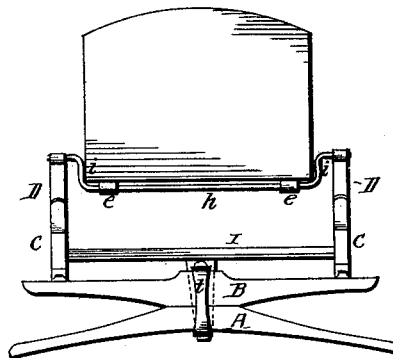

Attest:

*Fred Benjamin*  
*E. A. Wells*

Inventor  
*W. Chegwin*  
By his attorney  
*Charles E. Foster*

# UNITED STATES PATENT OFFICE.

WILLIAM CHEGWIN, OF FOND DU LAC, WISCONSIN.

## IMPROVEMENT IN VEHICLE-SPRINGS.

Specification forming part of Letters Patent No. 206,862, dated August 13, 1878; application filed January 5, 1878.

*To all whom it may concern:*

Be it known that I, WILLIAM CHEGWIN, of Fond du Lac, Fond du Lac county, Wisconsin, have invented new and useful Improvements in Vehicles, of which the following is a specification:

The object of my invention is to produce an easy-riding vehicle or road-wagon, having two half-elliptic springs clipped to equalizing-bars above the bottom of the wagon, as described hereinafter.

In the drawings, Figure 1 is a sectional elevation, and Fig. 2 a front view, of a road-wagon with my improvements.

A A represent the axles, B the bolster, and C C spars, secured to the rear axle and bolster, and strengthened by iron plates *s* at the under sides, so as to be perfectly rigid, forming, with the axle and bolster, an unyielding frame. To the center of each spar C is clipped the center of an inverted semi-elliptic spring, D, which springs support the body. Heretofore in vehicles of this description the ends of the springs have had a longitudinal play in plates secured to the body, or, where the body is narrower than the width between the springs, the latter have been connected to links necessarily attached to arms projecting from the body, or to crank-bars beneath the bottom of the body.

In some cases the springs are inverted, attached to the body, and at the opposite ends to cranks on equalizing-bars turning in bearings on the frame or axles; but this necessarily brings the springs closer together and diminishes the width and lessens the stability of the platform. In other cases the equalizing-bars are attached to the body, the crank ends extending to the sides, where they are connected to the inverted springs secured to the side bars.

In order to overcome these objections and maintain a wide platform with a body of the most contracted width, hung as low as may be desired, I provide the body with bearings

*e* extending beyond each end, in which turn two bars, *h h*, each bent at the ends to form cranks *i i*, to which the ends of the springs are attached, as shown, the said bars insuring union of action of all the parts, permitting the springs to be separated to any extent and the use of a body of the most limited width.

Crank-bars have been supported by brackets projecting downward below the body; but they necessarily limit the length of the spring, requiring it to be rigid and unyielding, and preventing the body from being hung below the ends of the spring.

A further advantage results from suspending the body of the bar from points at some distance above the bottom, so as to insure stability and permit a swinging suspension, insuring an elastic support not otherwise attainable and a level-riding wagon.

To insure a stronger connection of the front axle and frame, a tongue, *t*, is secured at one end to a cross-bar, I, supporting the steps *m*, and is bent round below and outside the bolster and front axle, and over the top of the bolster, and secured by the king-bolt, as shown in Fig. 1.

Further strength is insured by diagonal braces *n n* from the spars to the rear axle.

I claim—

The combination, in a vehicle, of the spars C, forming side pieces of the frame, inverted springs D, connected to the spars and extending beyond the ends of the body rods *h h*, supported in bearings beyond the ends of the body, and having cranks suspended from the ends of the springs, all as set forth.

In testimony whereof I have signed my name to this specification in the presence of two subscribing witnesses.

WILLIAM CHEGWIN.

Witnesses:

M. M. GILLET,  
K. GILLET.