

R. F. GIBSON & R. P. McDANIEL.
Combined Cotton Scraper and Chopper.

No. 206,871.

Patented Aug. 13, 1878.

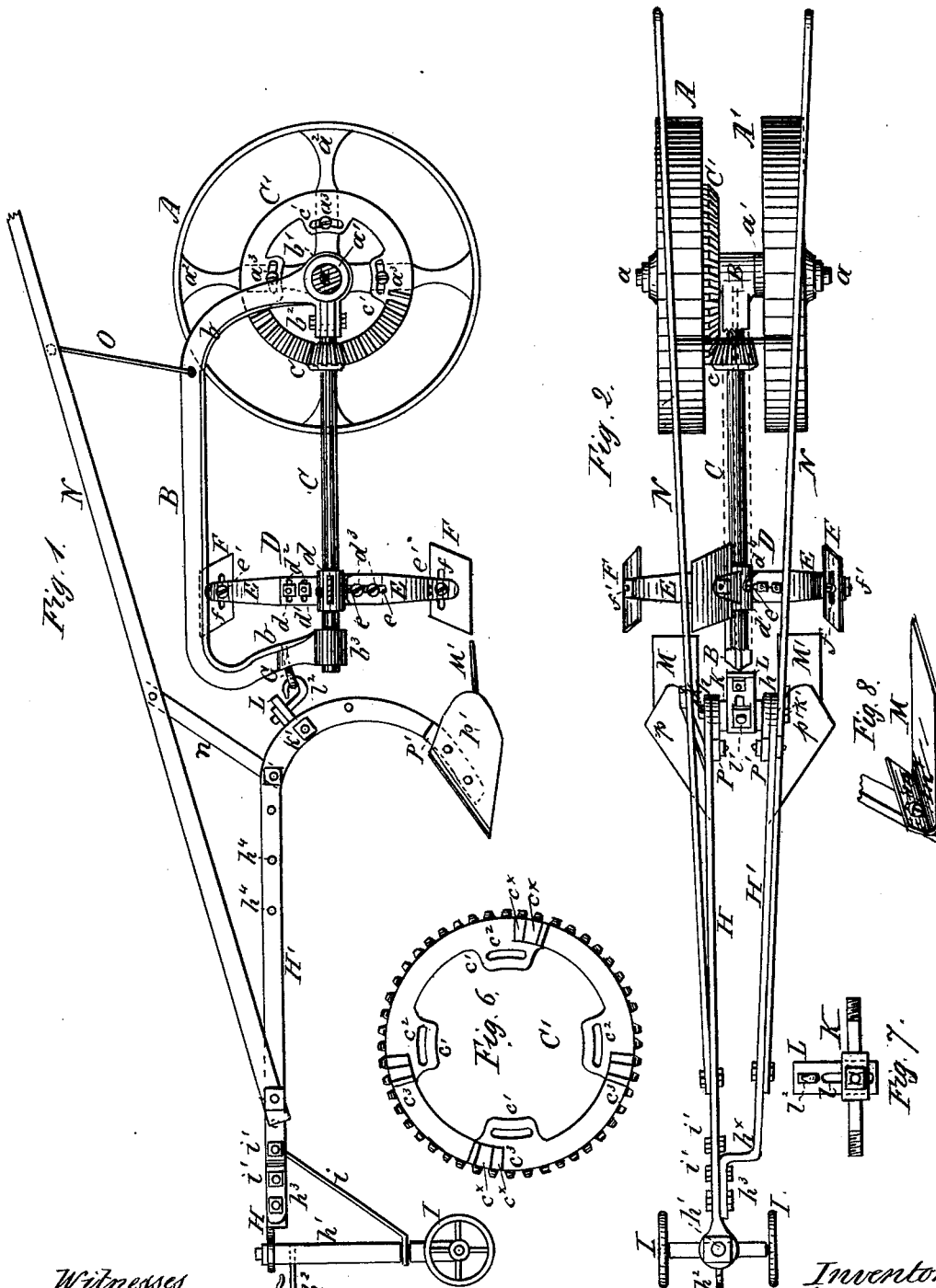

Witnesses
 Alf. L. Leonard
 Henri Guillaume

Inventors
 Richard F. Gibson
 Richard P. McDaniel
 per Henry Orth atty

R. F. GIBSON & R. P. McDANIEL.
Combined Cotton Scraper and Chopper.

No. 206,871.

Patented Aug. 13, 1878.

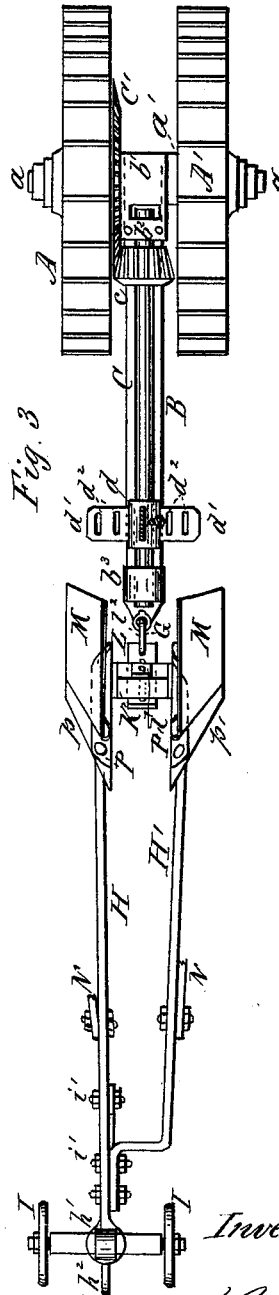
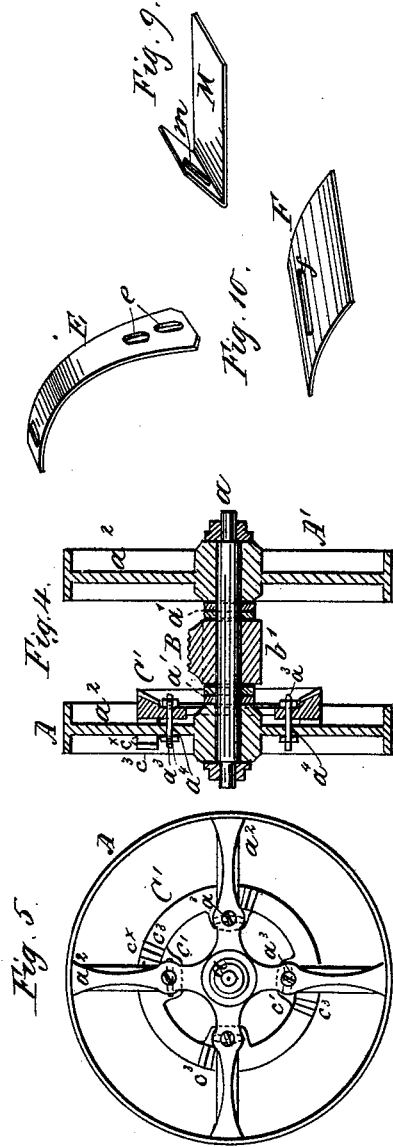

Witnesses.
 Chas. C. Leonard
 Henri Guillaume

Inventors
 Richard F. Gibson
 Richard P. McDaniel
 J. Henry Orth atty.

UNITED STATES PATENT OFFICE.

RICHARD F. GIBSON AND RICHARD P. McDANIEL, OF TUSCALOOSA COUNTY,
ALABAMA.

IMPROVEMENT IN COMBINED COTTON SCRAPER AND CHOPPER.

Specification forming part of Letters Patent No. 206,871, dated August 13, 1878; application filed
July 15, 1878.

To all whom it may concern:

Be it known that we, RICHARD F. GIBSON and RICHARD P. McDANIEL, of the county of Tuscaloosa, in the State of Alabama, have invented new and useful Improvements in Combined Cotton Chopper and Scraper, of which the following is a specification:

Our invention relates more particularly to certain details of construction and arrangement of mechanism, as fully described hereinafter, and shown in the accompanying drawings, in which—

Figure 1 represents, in side elevation, and Figs. 2 and 3, respectively, in top and bottom plan views, a combined chopper and scraper constructed according to our invention, part of the mechanism being broken away. Fig. 4 is a transverse section through line *xx* of Fig. 3. Fig. 5 is a side elevation of the drive-wheel having the toothed wheel attached, and Fig. 6 is a side elevation of the latter. Fig. 7 is a detached view of the shaft connecting the rear ends of the plow-beams. Fig. 8 shows one of the drags attached to plow-foot, and Fig. 9 shows said drag in perspective. Fig. 10 represents, in perspective, the chopper-hoe and its stock or foot.

Similar letters of reference are employed in the above figures to indicate corresponding parts wherever they may occur.

A A' are the drive or ground wheels, mounted upon an axle, *a*, upon which axle said wheels may be adjusted laterally by means of washers *a¹ a¹*, to increase or diminish the space between said drive-wheels according to the width of the drill or row of cotton. *B* is an arched cast-iron frame, the arms *b* of which form the bearings *b¹ b² b³*, the former to receive the shaft *a*, and the two latter for the rotary chopper-shaft *C*, in which bearings said shafts revolve freely.

Upon the rear end of shaft *C* is keyed a bevel-pinion, *c*, which meshes with a corresponding toothed ring, *C'*, bolted to the spokes *a²* of wheel *A*. This toothed ring is adapted for lateral adjustment upon the spokes *a²*, so as to keep the ring and pinion in gear whenever the wheels are adjusted upon the axle *a*, which is effected by the following means: Upon the inner periphery of the ring *C'* are cast

a series of ears, *c¹*, provided with segmental slots *c²* for the passage of bolts *a³*, and upon the rear face of said ring are formed a series of stepped projections, *c³*, immediately above and at one side of the center of the ears *c¹*, each provided with three or more steps, *c^x*, one higher than the other, the number of these stepped projections being equal to the number of slotted ears *c¹*, as will be readily understood, and as shown in Figs. 1, 4, 5, and 6. The number of slotted ears *c¹* and stepped projections *c³* is equal to the number of spokes of the drive-wheel *A*, which spokes are provided with bolt-holes *a⁴*, through which pass the bolts *a³* for securing the ring *C* in proper position upon the spokes.

It will be readily understood that when the space between the wheels is increased by moving one or both of them outward the toothed ring must be moved inward correspondingly, in order to mesh with the pinion *c*, which may be readily effected by removing the bolts *a³* and placing the next shoulder or step *c^x* against the spokes, or by removing the toothed wheel a distance equal to the height of the third step, or vice versa, according to the width of the row. By these means the chopper may be employed upon any land.

D is a rotary chopper consisting, essentially, of a hub, *d*, provided with spokes *d¹*. Each spoke is provided with transverse slots *d²* for the passage of bolts *d³*, by means of which the hoe or chopper stocks *E* are secured in place, which latter are provided with longitudinal slots *e*, through which pass said bolts *d³*. The shovel or chopper stocks *E* are slightly curved at their upper extremities, as shown at *e'*, and to these curved ends are bolted the slightly curved and rhomboidal shovels *F*, each provided with a longitudinal slot, *f*. (See Figs. 1, 2, 3, and 10.)

In order to regulate the depth of the cut of the choppers relatively to that of the scrapers, hereinafter described, and also to adjust the line of travel of said cutters or choppers around their shaft closer to or farther from the drags of the scrapers, and further to regulate the angle at which each chopper or cutter shall enter the ground, I move the spider or wheel *d d¹* upon its shaft either closer to

or farther from the drags, hereinafter more fully referred to and described, by means of the set-screw d^4 , which serves to secure the chopper rigidly upon its shaft, while the depth of the cut is regulated by moving the hoe-stock E inward or outward upon the spokes by means of the longitudinal slots e , the line of travel and the angle at which the shovels or hoes are to enter the ground being regulated by means of the transverse slots d^2 in the spokes d^1 and the bolts d^3 , as well as the longitudinal slots f in the hoes F and the bolts and nuts f^1 . The forward end of the arched frame B is provided with a swiveled eyebolt, G, by means of which the chopper is connected with the plow or scrapers, which I will now more fully describe.

H represents a plow-beam, the rear end of which is curved to receive a plow stock or foot, as shown at h . The forward end of the plow-beam H forms a bearing for the standard h^1 , through the lower end of which passes the axle which supports two guide-wheels, I. The standard is further provided, at or near its upper end, with a clevis, h^2 , for hitching the draft-animals to the apparatus, and by means of the brace i the standard is braced to the beam H.

The front end of the beam H may be raised or lowered to raise or lower the points of the plows by changing the position of the brace i either toward the front or rear of the beam in the holes i' ; thus the depth of the cut of the plows is regulated at pleasure.

H' represents another plow-beam bent at right angles at its forward end, as shown at h^x , and provided with a lip or ear, h^3 , by means of which it is bolted to the plow-beam H, as shown, which latter is further provided with a number of holes, h^4 , whereby the relative position of the beams H H' and their respective plows may be adjusted.

P P' are the plow-feet, of curvilinear form, and these plow-feet are bolted to the curved ends of the plow-beams H H' in the usual manner. To each plow-foot is bolted a scraper, p p' , in such manner that these scrapers may be readily removed and any other plowshare attached in their place; thus the scrapers p p' may be removed and cultivator-plows substituted to convert the scraper into a cultivator, or right and left hand shovels may be bolted to the plow-feet when desired.

The two plow-beams H H' are connected together at their rear ends by means of an adjustable brace-shaft, K, rounded at both ends and square in the center, as shown. Both ends of the brace shaft or rod are screw-threaded, and by means of the nuts k k' the beams may be set to any width of drill. L represents a slotted coupling-bar provided with a longitudinal slot, l , through which passes the coupling-bolt l' , the outer ends of which are screw-threaded to receive a nut, by means of which it is secured in position upon the shaft K, Fig. 7, while the hook l^2 engages with the eye of the bolt G to connect the scraper with the chopper. By means of the

slot l the shaft upon which the chopper is mounted may be adjusted relatively to the drags, as will be readily seen.

Behind each scraper p p' is an adjustable drag, M M', provided with vertical slots m , through which pass the bolts m' , by means of which the drags are bolted to the plow-feet, their position relatively to that of the plows or scrapers being adjusted by means of the slots m and bolts m' .

It will be readily seen that as the plows pass through the ground on each side of a drill to throw the earth outward the drags following immediately behind said plows or scrapers level the ground and form a smooth surface of sufficient width for the wheels A A', which fact greatly facilitates the handling of the apparatus, and also causes it to run much easier over the ground, thus effecting a saving in power. Of course it will be understood that the scrapers and drags are upon the same line with the ground-wheels A A'.

N N are the handles, detachably connected with the plow-beams H H' at their forward end by means of bolts and nuts, and n n are braces, by means of which said handles are braced to the rear end of said plow-beams. O is a connecting-rod connecting the cross-bar n' of the handles with the arched beam B of the chopper, by means of which the latter may be readily raised or handled.

It will be seen from what has been said above that by means of the peculiar construction and arrangement of parts I obtain a combined chopper and scraper which may be readily converted into a combined chopper and cultivator, or into a cultivator, by detaching the plow from the chopper, or a common plow by attaching the ordinary plow-handles and the respective shovels or shares, capable of any desired set in width; or the plows may be adjusted so as to follow each other, as desired. The chopper may also be attached to front of plow to chop the cotton, and the plows following said chopper may be made to hill it by throwing the earth up on each side of the row or drill. The apparatus may also be employed in another way for the cultivation of cotton. The scrapers may be used alone to run around the cotton before it is sufficiently large to be chopped, to prepare the crop for the chopper, and when of sufficient growth the chopper may then, as above stated, be hitched to the front of the scrapers, throwing the beams wide enough apart for the action of suitable cultivator-shovels attached to the plow-feet. In lieu of the scrapers, the crop may be chopped and cultivated at the same time.

Having now described our invention, what we claim, and desire to secure by Letters Patent, is—

1. In a combined cotton chopper and scraper, the combination of the laterally-adjustable plow-beams carrying the scrapers, the vertically-adjustable drags, a horizontally, vertically, and laterally adjustable rotary chopper

and its driving-pinion, the laterally-adjustable drive-wheels, and a correspondingly-adjustable toothed ring, all constructed and operating as and for the purposes set forth.

2. In a cotton-chopper, an adjustable toothed ring adapted for adjustment upon and to and from the spokes of one of the drive-wheels, substantially as described, for the purpose specified.

3. The toothed ring C', provided upon its inner periphery with ears c^1 , having segmental slots c^2 , and upon its rear face with stepped projections c^3 , substantially as described, for the purpose specified.

4. In a cotton-chopper, the combination of a pair of drive-wheels laterally adjustable upon their axle, an arched frame carrying a rotating chopper-shaft, also adjustable laterally upon the drive-wheel axle and carrying a bevel-pinion, and a toothed ring adapted to mesh with said beveled pinion, said toothed ring being also adjustable upon the spokes or arms of one of the drive-wheels, so as to maintain said pinion and gear-wheel or ring in gear when the drive-wheels are moved toward or from each other, as described, for the purpose specified.

5. In a combined cotton chopper and scraper, the combination, with the drive-wheels of the former, of a pair of scrapers followed by a pair

of drags upon a line with that of said drive or ground wheels of the chopper, substantially as described, for the purpose specified.

6. The combination, with the chopper D, of the drags M M' and the scrapers $p p'$, all constructed, arranged, and operating substantially as described, for the purpose specified.

7. The combination, with the plow-beams H H' and the chopper-frame B, of the brace-shaft K, the nuts $k k'$, the slotted bar L, coupling-hook l , and eyebolt G, all constructed and operating as and for the purposes specified.

8. The combination of the plow-beams H H', the brace-shaft K, and nuts $k k'$ with the drive-wheels A A', axle a , and washers $a^1 a^1$, substantially as and for the purposes specified.

9. The combination of the plow-beams H H', the shaft K, and nuts $k k'$ with the drive-wheels A A', axle a , washers $a^1 a^1$, adjustable toothed ring C', chopper-frame B, shaft C, pinion c , and chopper D, all arranged and operating substantially as and for the purposes specified.

In witness that we claim the foregoing we have hereunto set our hands this 10th day of July, 1878.

RICHARD F. GIBSON.
RICHARD P. MCDANIEL.

Witnesses:

S. M. COWLTON,
J. S. BLACKBURN.