

E. GOUPTEL.
Machine for Ruling Paper.

No. 206,873.

Patented Aug. 13, 1878.

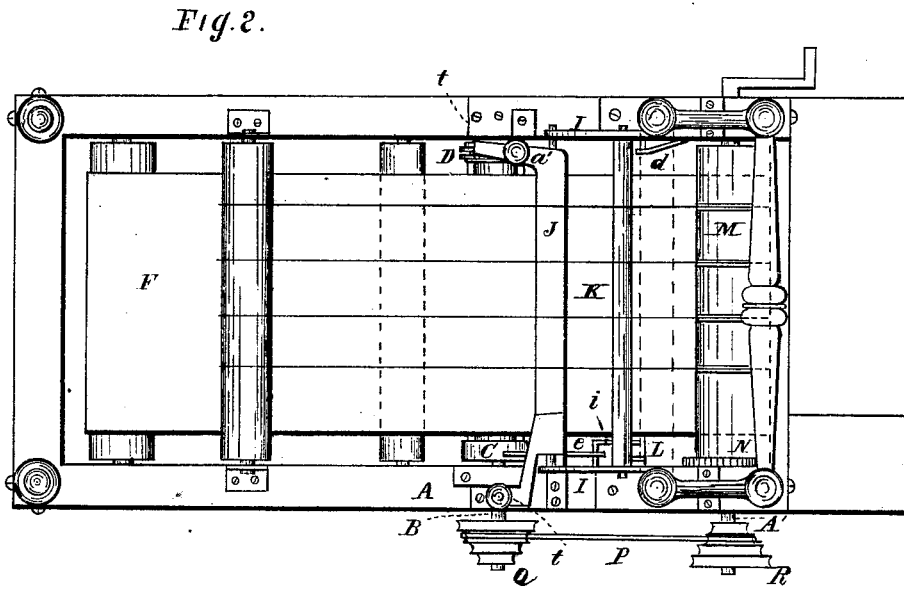
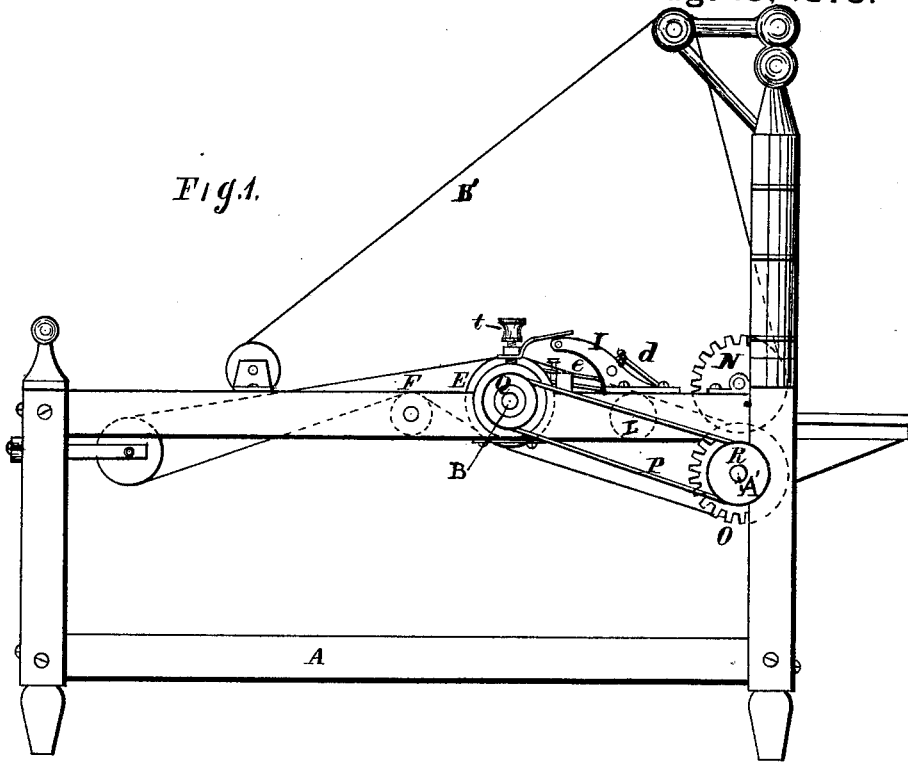

Witnesses
J. P. Abbott
W. S. Elliott

Inventor.
 Elmer Goupitel
 per *Burridge & Co.*
 Atty.

E. GOUPTEL.
Machine for Ruling Paper.

No. 206,873.

Patented Aug. 13, 1878.

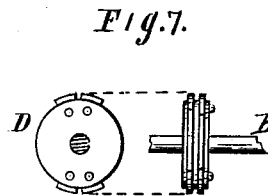
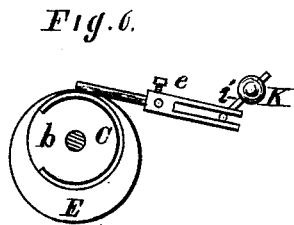
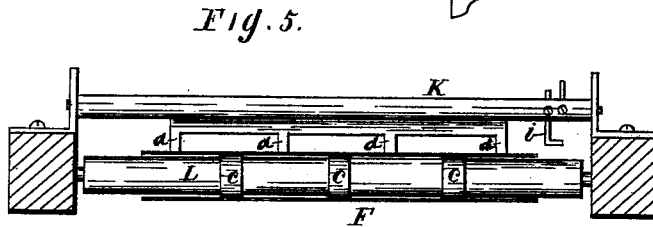
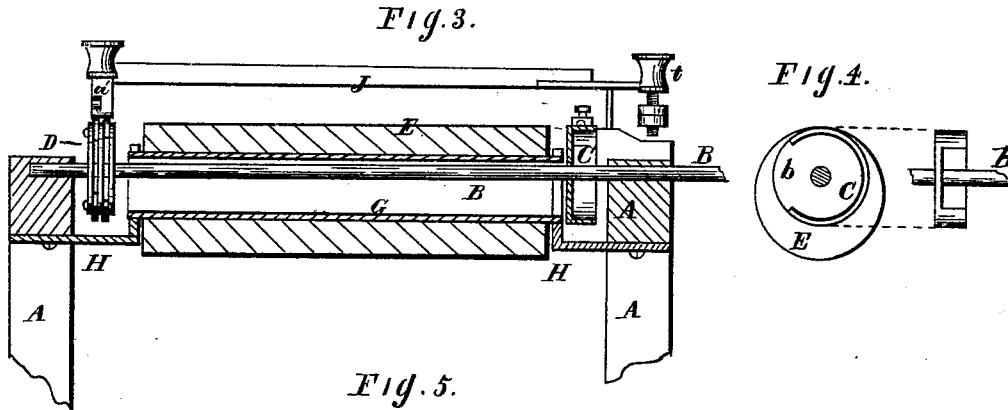

Witnesses.
J. P. Abbott
M. Gillett

Inventor.
Edmond Goupitel
per Bessing & Co
attys

UNITED STATES PATENT OFFICE.

ELMER GOUPTEL, OF CLEVELAND, OHIO.

IMPROVEMENT IN MACHINES FOR RULING PAPER.

Specification forming part of Letters Patent No. **206,873**, dated August 13, 1878; application filed February 25, 1878.

To all whom it may concern:

Be it known that I, ELMER GOUPTEL, of Cleveland, in the county of Cuyahoga and State of Ohio, have invented new and useful Improvements in Ruling-Machines, of which the following is a description, reference being had to the accompanying drawings, making a part of this specification, in which—

Figure 1 is a side elevation of the machine. Fig. 2 is a plan view.

The figures on Sheet 2 are detached sections, to which reference will be had.

Like letters of reference refer to like parts in the several views.

The nature of this invention relates to a machine for ruling paper, and which consists of a novel mode of rotating the apron whereon the paper is laid independent of the rotative movement of the shaft carrying the cams whereby the ruling-pens are actuated.

Also, the improvement relates to certain bands placed around the roller beneath the gate of the machine to prevent the paper from slipping under the gate.

A further and more full description of the invention and the operation thereof are as follows: In the frame A is journaled the shaft B, carrying the cams C and D, Fig. 2. Detached views of the cams are shown in Figs. 4 and 7, and a more complete view of the shaft in Fig. 3. Said shaft B passes through a hollow roller, E, Fig. 1, over and under which runs the endless apron F, Fig. 2, whereon is laid the paper for being ruled. The hollow roller alluded to is lined with a bush, G, Fig. 3, the ends of which project beyond the ends of the roller, and form journals, on which it revolves in the brackets H, supporting the roller in its relation to the shaft B and the cams thereon.

It will be observed that the shaft and the roller have not a common axis of rotation, but that each revolves separately and independently upon its own shaft or journals; hence their movements may be synchronous or not, for a purpose presently shown.

The cam-shaft is also placed eccentrically to the axis of the cylinder, so that the top surfaces of the cams may be level with, or a little above, the surface of the cylinder, so that the small cams set in the grooves can be reached for the purpose of adjustment, as they are held

by set-screws, which could not be reached if they were much below the rail and the top of the cylinder.

It will also be observed in Fig. 3 that the surface of the cams C and D are in line with the upper surface of the roller, or nearly so.

I, Figs. 1 and 2, are a pair of arms, in the ends of which is journaled the pen holder or beam J. The pens are not shown, but are the same as those in use in ruling-machines. Near the base of the arms is journaled the gate K. (Shown more clearly in Fig. 5.)

The fingers A of the gate reach to and press lightly upon the surface of the apron directly above the supporting-roller L, Fig. 2, or nearly so, over which the apron runs. Said roller is more fully shown in Fig. 5, in which it will be seen that around said roller, between the fingers, are bands *c*, whereby the apron is raised slightly above the face of the roller, but which may be depressed a little between the bands by the fingers, for a purpose hereinafter shown.

The pen-beam above alluded to is vibrated for lifting the pens from the paper by the cams D, over which the arm *a'* of the beam rides as the cams revolve. Said cams are the same as those employed in the ordinary ruling-machine, and operate in the same way.

The gate K, above described, is vibrated by the cam C, through the intervention of the lever *e*, Figs. 1 and 2, a detached view of which is shown in Fig. 6. Said lever is pivoted to an arm secured to the side of the frame, and so arranged that one end thereof rests upon the face of the cam.

The opposite end of the lever is bifurcated, and engages an arm, *i*, projecting from the gate K, substantially as shown in Figs. 2 and 6.

It will be seen that the face of the cam C is not continuous, there being a break therein, as shown at *b*, Figs. 4 and 6; hence as the cam revolves the end of the lever *e* will fall into the break or space in the cam, and the lever is caused to fall suddenly therein by the spring *d*, Figs. 1 and 2, attached to the gate and side of the frame.

Further reference will be had to this part of the machine.

The cams C and D are revolved by the roller

a

M, Fig. 2, primarily by said roller's engagement with a corresponding roller directly below it, through means of the cog-wheels N and O, Fig. 1, respectively secured to the rollers or shafts thereof. From the roller carrying the cog-wheel O motion is transferred to the shaft B by a belt, P, and the cone-pulleys Q and R, respectively secured to the shafts B and A'.

The course of the endless apron above referred to will be understood from Figs. 1 and 2, and also the course of the binding-cords B', which are like those used in this class of machines.

Having described the construction and arrangement of the several parts of the machine, the practical operation of the same is as follows: In ordinary ruling-machines the pen-roller and the cams for operating the pen-beam, and also the gate, are arranged upon the same shaft, and therefore they rotate together, making their respective revolutions in the same time. This synchronous operation of the roller and cams involves the necessity of having a number of pen rollers or cylinders of various diameters, according to the length of the paper to be ruled. To change one cylinder or roller for another of a different diameter is attended by much time and trouble, to avoid which is the purpose of having in my machine the pen-cylinder, and the cams revolve independently of each other; hence the pen cylinder or roller may continue to rotate any number of times, as the length of the sheets of paper may require, whereas the cams for lifting the pens may be caused to revolve slowly by shifting the belt P on the cone-pulleys, as the nature of the case may require—that is to say, according to the length of time that the cams are required to revolve before the pens are to be lifted.

The movement of the cams in respect to the movement of the pen-roller is such that the pens will be lifted from the paper on or about the time that the paper has run its length over the roller.

It will be obvious that by this separate and independent movement of the pen roller or cylinder, and that of the cams, short and long sheets of paper can be ruled on the same roller by simply shifting the belt P so that the cams shall rotate once during the time the paper is passing over the roller. In so far as the movement of the apron is concerned and the binding-cords B', together with the pens, the operation is the same as that in the ordinary ruling-machines.

The pen-roller is larger in my machine than those in other machines. Hence the paper is supported on a broader surface, and therefore it is less liable to yield to the pressure of the pens; hence the ruling is better done than when the roller is of small diameter, as it must be in order to rule short sheets of paper in ordinary machines.

It may be proper to state here that, in mak-

ing the change of pen rollers or cylinders from one size to another, as required in other machines, for the purpose above specified, the apron must be shortened or lengthened as the changing of the rollers may demand. This, however, is avoided by using one roller working independently of the cams, as herein described.

As above said, the gate K is operated by the lever *e*. So long as the end of the lever rests upon the face of the cam the fingers of the gate will press lightly and firmly upon the surface of the paper as it lies upon the apron, and against which fingers the following sheet of paper is held back from moving forward with the apron while the preceding one is being ruled. By the time the ruling is done the notch or break in the cam has made one revolution, thereby allowing the end of the lever to fall into it, at which moment the spring *d* partially rotates the bar of the gate, throwing the fingers thereof so far above the paper as to allow the next sheet of paper, which the fingers had held back, to pass under them to be ruled. The break in the cam having been passed over, the lever again comes upon the face of it, and the fingers of the gate thereby brought down upon the sheet being ruled, and keeping back the next in order of succession.

By this device in operating the gate the paper is held firmly down upon the apron and the fingers from not being lifted directly upward from the paper; but by a slight rotative or an advanced upward movement from the edge of the following sheet of paper the edge thereof is not liable to be lifted by the fingers, and thereby more or less moved out of place, which the sheet is likely to be when the gate is operated as in other machines. The direction of the fingers of the gate while the ruling is being done is downward, as shown in Fig. 5; but when they are lifted from the paper they are thrown slightly forward and upward, as shown in the drawings, for the purpose above stated.

The pen-beam in ordinary ruling-machines has a set-screw in one end, whereby it strikes upon a firm base or rest. The opposite end of the beams strikes upon a spring. This arrangement is objectionable for the reason that, while one end of the beam is held or checked firmly by the striking-screw, the opposite end of the beam, in striking upon the spring, falls a little lower in consequence of the yielding of the spring, thereby causing the pens to tremble and to bear unequally upon the paper, so that they make unequal lines, and, furthermore, the spring is liable to move laterally, causing the pens to waver and make wavy lines.

In order to avoid this objectionable feature in the working of ruling-machines, I use a set-screw on both ends of the beam, as shown at *t* in Fig. 2. In using two set-screws or striking-screws instead of one only and a spring, the pen-beam is made to strike evenly and alike upon

the rests, and, being thereby held firmly and steadily, there is no trembling of the pens; hence the ruling is done without wavy lines.

The roller near the gate in ruling-machines now generally in use has a uniform surface, and, being hard and smooth, keeps the apron in contact firmly with it, so that it does not yield to the pressure of the fingers unless pressed so hard thereon as to prevent a free movement of the apron, and unless the fingers do press with some force the paper lying thereon is liable to become displaced sidewise more or less. To prevent such displacement is the purpose of the bands *c*, above alluded to, placed around the roller, as shown in Fig. 5. Said bands raise the apron a little above the face of the roller, so that the fingers, on pressing upon the apron, slightly depress it between them,

thereby preventing a lateral displacement of the paper lying thereon and depressed therewith.

What I claim as my invention, and desire to secure by Letters Patent, is—

1. The hollow cylinder or pen-roller *E*, mounted independently of and eccentrically to the shaft *B*, in combination with the shaft *B* and the cams *C D*, substantially as and for the purpose described.

2. The roller *L*, provided with bands *c*, in combination with the apron *F* and gate *K*, substantially in the manner as described, and for the purpose specified.

ELMER GOUPTEL.

Witnesses:

J. H. BURRIDGE,
JOHN SWEENEY.