

H. A. HOUSE.
Machine for Crocheting Fabrics.

No. 206,878.

Patented Aug. 13, 1878.

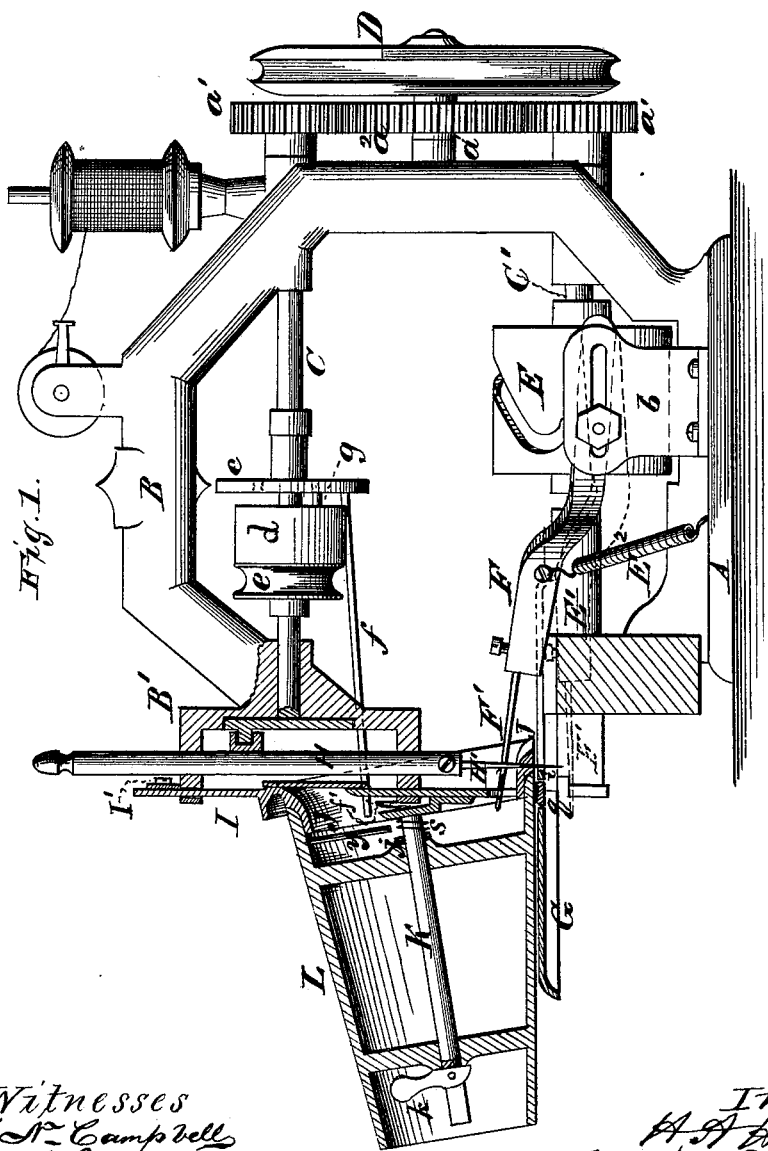

Witnesses
L. R. Campbell
W. C. Schaffer

Inventor
H. A. House
By *Atty R. Campbell*

H. A. HOUSE.
Machine for Crocheting Fabrics.

No. 206,878.

Patented Aug. 13, 1878.

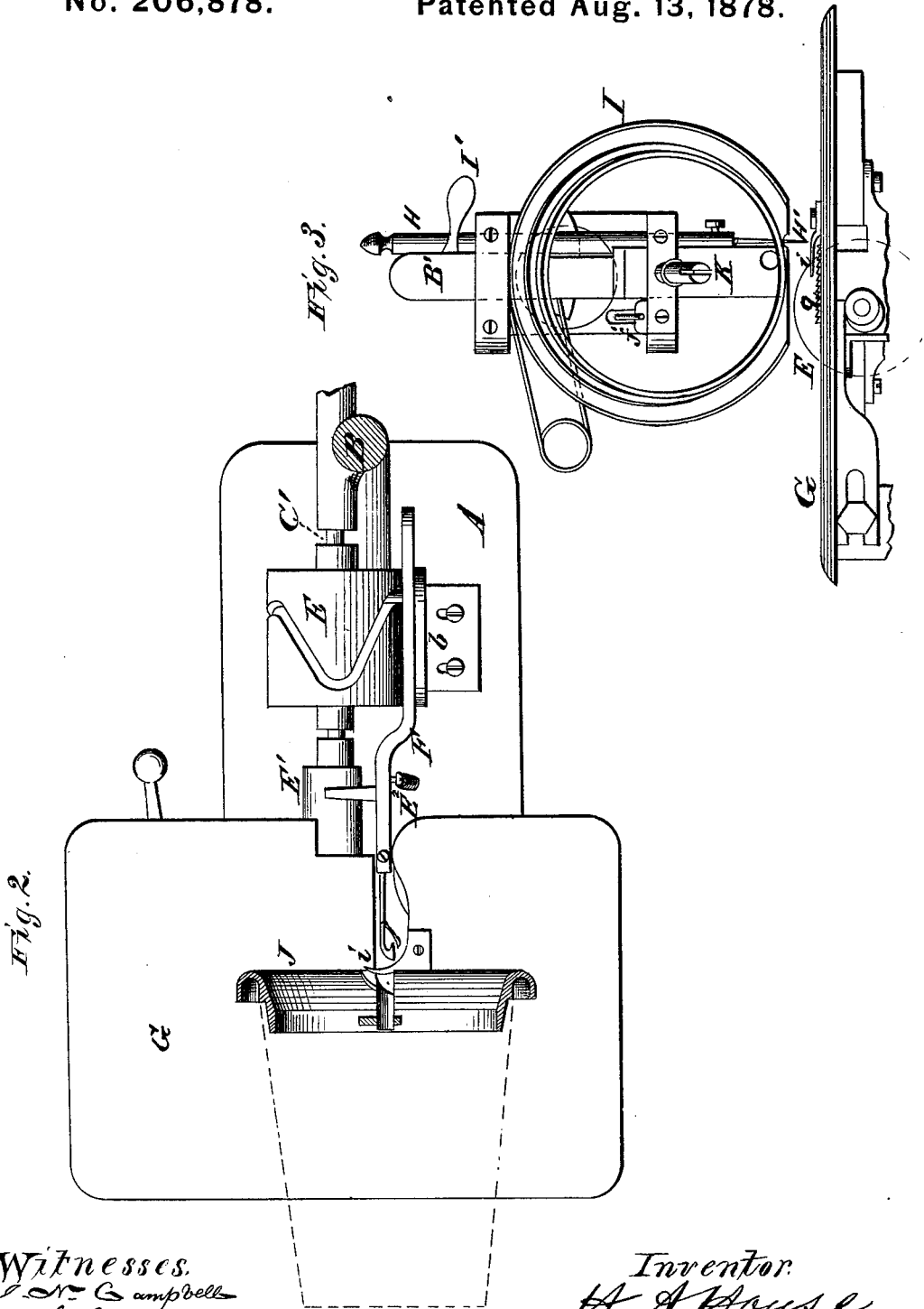

Witnesses.
J. N. Campbell
W. E. Schaffner

Inventor.
H. A. House
By Atty R. Mansfield

UNITED STATES PATENT OFFICE.

HENRY A. HOUSE, OF BRIDGEPORT, CONNECTICUT.

IMPROVEMENT IN MACHINES FOR CROCHETING FABRICS.

Specification forming part of Letters Patent No. **206,878**, dated August 13, 1878; application filed February 11, 1878.

To all whom it may concern:

Be it known that I, HENRY A. HOUSE, of Bridgeport, in the county of Fairfield and State of Connecticut, have invented certain new and useful Improvements in Machines for Crocheting Fabrics; and I do hereby declare that the following is a full, clear, and exact description thereof, which will enable others skilled in the art to which it appertains to make and use the same, reference being had to the accompanying drawings, and to letters of reference marked thereon, which form a part of this specification.

The nature of my invention consists in a machine which is adapted for crocheting, as will be hereinafter explained.

In the annexed drawings, A represents the base-plate of an overhanging frame or bracket, B, constructed with journal-boxes adapted to afford bearings for two long shafts, C C', and a short stud or shaft, *a*. Shafts C C' bear on their rear ends pinion-wheels *a*¹ *a*¹, which engage with an intermediate wheel, *a*², on short shaft *a*, which shaft also carries a wheel, D, which is adapted either for a belt-wheel or a hand-crank wheel, and may be used, if desired, for giving motion to the machine; but I prefer a plan hereinafter explained for this purpose.

Frame B may be provided with a bobbin-stud, and also with a tension device for the yarn used in crocheting.

The shaft C' has a zigzag-slotted cam-drum, E, and also a single-throw cam, E¹, keyed on it. The slotted cam E receives an anti-friction wrist-pin, which plays in a horizontal slot formed in the standard *b*. The wrist-pin is attached to a needle-arm, F, carrying a latch-needle, F', on its front end, and receiving longitudinal motion from the cam E. The end of needle-arm F receives vertical motion from the cam E¹ and a helical spring, E². The latch-needle F' and the front end of the needle-arm F play freely up and down through a slot made through the cloth-plate G, which latter is bolted to a standard rising from the base A. The shaft C, which is above the shaft C', is provided with a longitudinally-movable disk, *c*, a keyed hub, *d*, and a loose grooved driving-pulley, *e*. The longitudinally-movable disk is loosely applied on shaft C, and is constructed

with a long spring-rod, *f*, which passes through the head B'.

The hub *d*, which is keyed on shaft C, as above described, is provided with a longitudinally-movable spring-pin, *g*, which is held against the disk *c* by a spring, and which is designed to enter one or the other of several holes made through the pulley *e*, and thus engage this pulley with the shaft C when the disk *c* is pressed forward with the fingers.

Rod *f* has a notch near its front end, which engages with a knife-edge plate, *f'*, when disk *c* is thrown forward, thus holding the said pulley engaged with its shaft.

H designates a needle-bar, carrying the well-known eye-pointed needle H' on its lower end, adjusted so that its eye is at right angles to the plane of the longitudinal motion of the latch-needle F'. This bar H receives its motion directly from the shaft C, which motion harmonizes with the movements of the said latch-needle. On one side of the needle H', and rigidly fixed to the upper side of the cloth-plate, is a curved yarn-holder, *i*, over and under which the loops are formed. When the latch-needle recedes above the holder *i* it carries the yarn over this holder *i*, and when the latch-needle makes its forward stroke beneath this holder *i*, the latter arrests the yarn until it is shed from the latch-needle. The same operation occurs during the forward stroke of the latch-needle above the yarn-holder *i*.

By the combined operation of an eye-pointed needle, a latch or looping needle, and a curved horn or yarn-holder, *i*, I am able to form what is known as a "selvage" on the edge of a piece of tubular or straight fabric, or to crochet on any part of a straight piece of fabric.

I designates a pressure-bar guided by the head B', which bar is adjustable by a cam-lever, I', acting on the upper end of said head. To this bar I is rigidly attached a flanged and shouldered guard-ring, J, also a shaft, K, which is concentric to said guard-ring, and which is slightly inclined with respect to the plane of the cloth-table.

On the shaft K is applied a tapered horn, L, the base of which is concentrically applied on the shaft, which is held up against a shoulder, *j*, on the guard-ring by means of a cam-lever, *k*, having its fulcrum on the shaft K, by

adjusting which latter the horn can be adjusted endwise, for a purpose hereinafter explained.

The lower portion of the outer flange of the guard-ring J is cut away, so that when this ring is depressed by lowering the pressure-bar, the periphery of the horn or holder will be caused to bear the cloth upon the serrated feeder *g*, so that at each backward stroke of this feeder the horn or holder will be turned about its shaft a proper distance to form a loop. The holder is held against the lever *k* by means of a coiled spring, *s*, acting against its largest closed end.

The object of having the holder endwise adjustable is to enable the operator to form more than one row of crochet-loops, thus making a selvage more compact than it would be if only a single row was formed.

Inside of the largest end of the horn or holder L, and secured to the outer portion thereof, is a short radial rod, *y*, which is fixed to the flange of said holder, and which operates on the free end of rod *f*, releasing this rod *f*, and allowing the disk *c* to be thrown back and the pin to disengage from the pulley *e*. This mechanism automatically stops the operation of the machine at each revolution of the horn L.

What I claim as my invention, and desire to secure by Letters Patent, is—

1. The combination, with the looper-bar F, of the cams E E' and spring E², arranged below the plane of the cloth-plate G, substantially as described.

2. An endwise-adjustable work-holder, L, which is allowed to rotate freely, in combination with the pressure-bar I and a cloth-feeder, *g*, substantially as described.

3. A tapered holder, L, adapted for tubular work, in combination with the bar I and a flanged guard, J, substantially as described.

4. A holder, L, for tubular work, in combination with the pressure-bar I, a flanged guard, J, serrated feeder *g*, and a cloth-plate, G, substantially as described.

5. In combination with a holder, L, arm *y*, and spring-rod *f*, the disk *c*, pin *g*, hub *d*, and pulley *e*, substantially as described.

6. In combination with a holder, L, which is longitudinally adjustable, and with the spring *s*, the lever *k* and shaft *k'*, substantially as described.

In testimony that I claim the foregoing as my own I affix my signature in presence of two witnesses.

HENRY A. HOUSE.

Witnesses:

GEORGE C. BISHOP,
A. B. BEERS.