

M. LYTLE.
Oil-Well Pumps.

No. 206,888.

Patented Aug. 13, 1878.

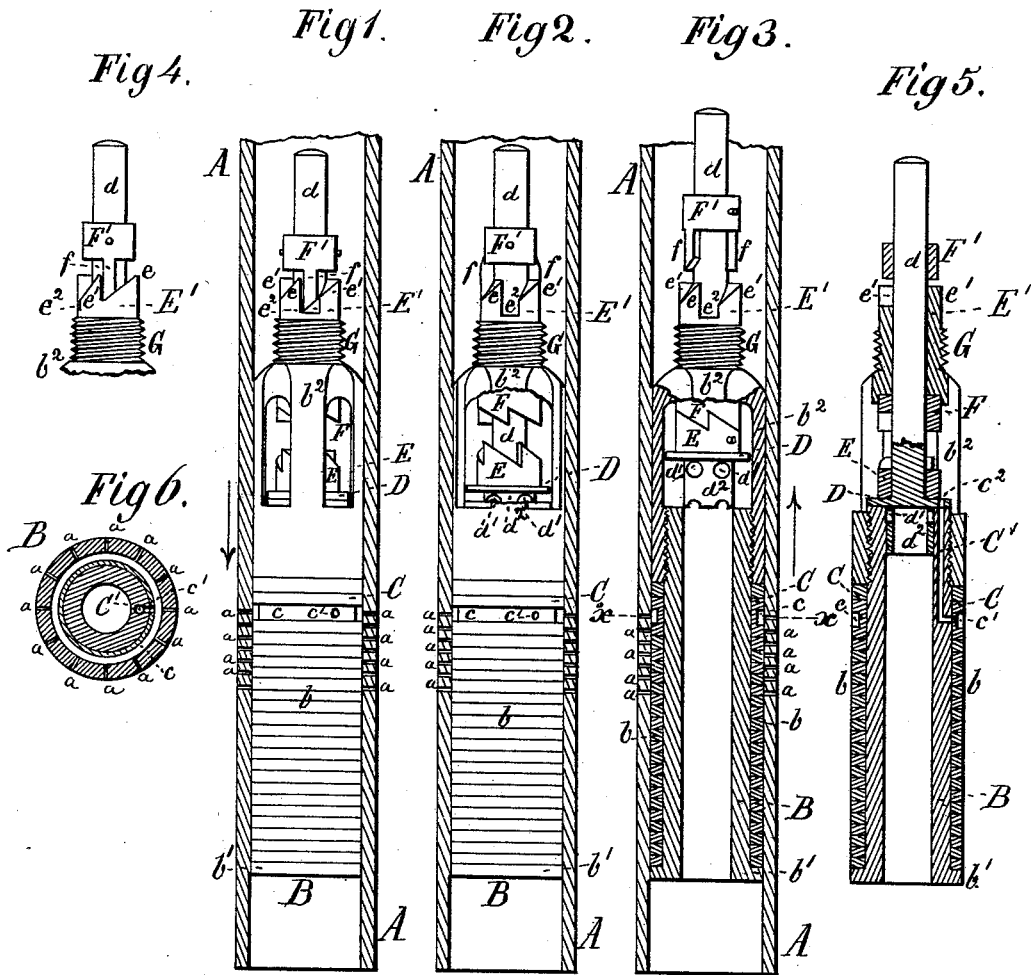

Witnesses:
J. P. Th. Lang.
Russell Carr

Inventor:
Munaid Lytle
by
Marion, Reunick & Lawrence

M. LYTLE.
Oil-Well Pumps.

No. 206,888.

Patented Aug. 13, 1878.

Fig 7.

Fig 8.

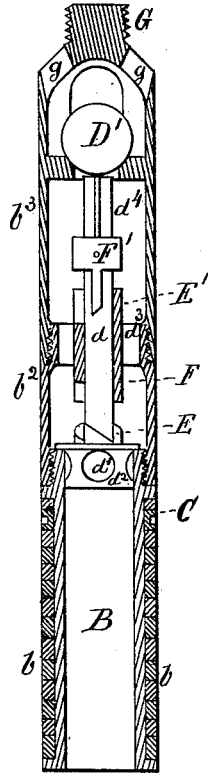
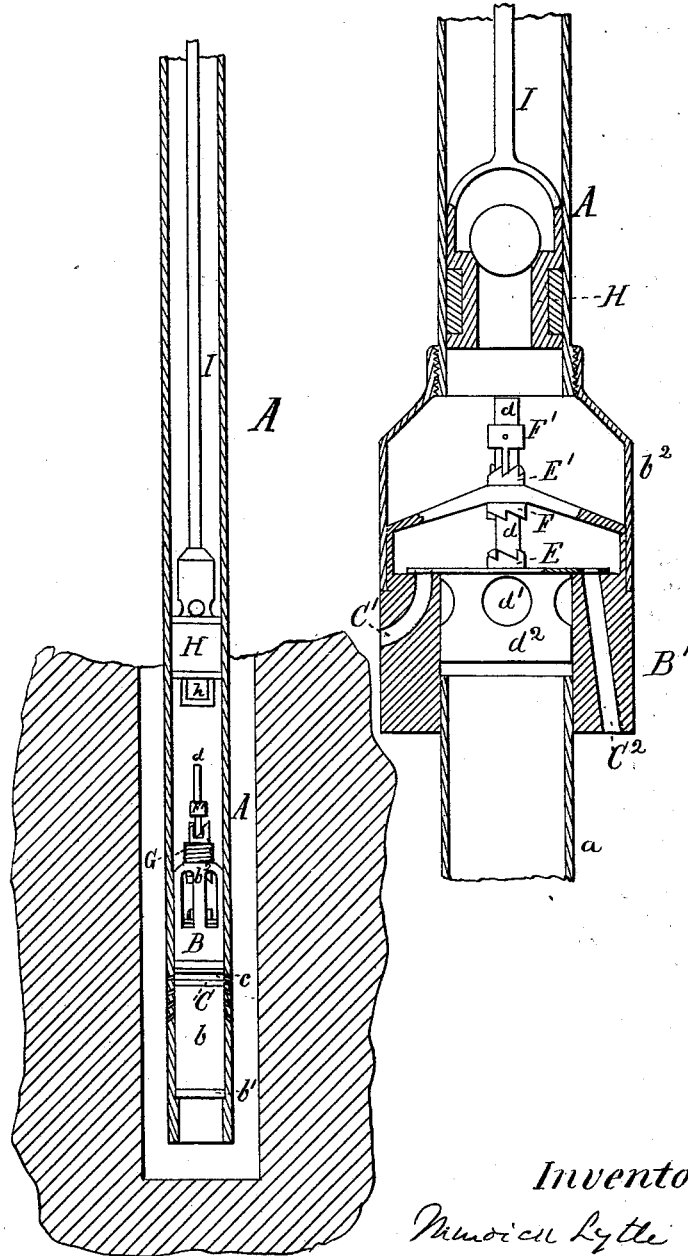

Fig 9.



Witnesses:
J. P. Th. Lang.
Russell Barr

Inventor
Munroe Lytle
by
Mason, Parwick & Lawrence

UNITED STATES PATENT OFFICE.

MURDICK LYTLE, OF OIL CITY, PENNSYLVANIA.

IMPROVEMENT IN OIL-WELL PUMPS.

Specification forming part of Letters Patent No. 206,888, dated August 13, 1878; application filed July 15, 1878.

To all whom it may concern:

Be it known that I, MURDICK LYTLE, of Oil City, in the county of Venango and State of Pennsylvania, have invented a new and useful Improvement in Oil-Well Pumps; and I do hereby declare that the following is a full, clear, and exact description of the same, reference being had to the accompanying drawings, forming part of this specification, in which—

Figure 1 is an elevation of a pump-valve provided with my improvements, and a section of an oil-well tube. Fig. 2 is a similar elevation and section, with a part of the case of the valve broken away to better exhibit the interior parts, and showing the valve partly elevated from its seat and turned one-quarter around its axis. Fig. 3 is a section of the lower part of the valve-case and an elevation of its upper part and valve thereof, which latter is shown at the end of its upstroke. Fig. 4 is a detail view of the upper part of the valve-case and valve, showing the same in a like position to that in Fig. 2, but turned one-quarter of a revolution. Fig. 5 is a vertical central section of the valve-case and valve, as shown in elevation in Fig. 1. Fig. 6 is a horizontal transverse section in the line *xx* of Fig. 3. Fig. 7 is a section of the lower part of a pump-barrel for oil-wells, wherein the application of my ratchet-valve is illustrated. Fig. 8 is a vertical central section of a modified construction of a standing valve having my ratchet-valve applied to it, and serving as a check or foot valve at the lower end of the pump. Fig. 9 illustrates how my improved ratchet-valve may be applied in an enlarged chamber at the foot of a pump. The pump-barrel and the valve-chamber are shown in section.

The nature of my invention consists, first, in an oil-well pump provided with a valve of such construction and operation that the major portion of oil or other fluid is lifted and discharged at the top of the well, and at intervals a portion of the oil or other fluid is, after being lifted, forcibly returned in a vertical direction, or both in a vertical and horizontal direction, back into the oil-well, and the horizontal discharges are from time to time effected independently of the vertical ones; second, in a hollow or vertically-perforated

valve-case and a spindle-valve, in combination with a double-ratchet mechanism of such construction that at every alternate downstroke the valve is kept at a distance from its seat, and thus permits a portion of the oil which has been raised above the valve to be forced down through the valve-seat into the oil-well, so as to violently agitate the oil and paraffine or other matters which tend to impede the proper flow of the oil at the bottom of the well; third, in the combination of a laterally-discharging passage or passages leading from the seat of the valve through the valve-case, or to the periphery of the same, with the valve provided with the double-ratchet mechanism, whereby a part of the oil which is forcibly returned downward under the partially-elevated valve is permitted to pass laterally through the valve-case against the sides of the well, or to the periphery of the valve seat or case, and from thence, through suitable side openings in the pump-barrel, into the oil-well in such a manner as to agitate the oil and accumulating paraffine around the sides of the well, while another portion is discharged vertically through the valve seat or case; fourth, in the combination of an opening or openings in the valve, provided with the double-ratchet mechanism, and a seat or case, provided with the lateral passage or passages, in such a manner that when the valve is fully down upon its seat a communication through the valve with the lateral passage or passages is secured once, or oftener, as desired, during the revolution of the valve, and thus the lateral discharges in a downward direction may be carried on periodically independently of the central discharges through the valve case or seat.

By my invention a collection of paraffine which would impede the flow of the oil and interfere with the operation of the pump is prevented, and at the same time the sides of the well are effectually washed.

A in the accompanying drawings represents the lower part of an oil-well tube or pump-barrel, and B a hollow valve-case. The tube A is provided, at a suitable elevation, with lateral openings *a*.

The case B is provided with a suitable packing, *b*, an outer flange, *b'*, and a valve-

cage, b^2 , which is screwed to the upper part of the valve-case B, and between it and the flange b^1 the packing b is secured and compressed.

A metal ring, C, with an annular groove, c , in it, which is intersected by a hole, c^1 , in the ring, is interposed between the upper and lower portions of the packing b . The hole c^1 connects with the lower terminus of the passage C¹ in the valve seat or case, which passage extends to the top of the valve-seat, and forms the channel for the lateral downward passage of the oil from the top of the valve-seat, or from the top of the valve D on said seat to the passages a a in the oil-well tube. The valve D is provided with a hole, e^2 , which periodically registers with the passage C¹, and it also has an upper stem, d , which passes through the upper part of the cage b^2 , and a lower hollow cylindrical guide, d^2 , with lateral openings d^1 . The valve-cage b^2 is provided with a lower central ratchet-wheel, E, and an upper one, E'.

The ratchet-teeth of the wheel E are all similar in form and equal in size, and those of the wheel E' are alternately of different construction from one another. One series of these teeth, e , are regular ratchet-teeth, and the other series, e^1 , have a deep notch, e^2 , at the bottom. The stem d is provided with a lower ratchet-wheel, F, and an upper one, F'.

The lower ratchet-wheel, F, is made to match with the ratchet-wheel E when the valve D is at its highest elevation. The upper ratchet-wheel, F', is provided with two diametrically-opposite elongated teeth, f , and made of such width as to enter the notches e^2 .

The ratchet-wheels F F' are placed so far apart that they will operate upon their counterparts E E' independently, and they are so set or fastened in such positions on the stem d that they will respectively match with the said counterparts by making a certain part of a revolution. There are four ratchet-teeth on the wheels E E', and the valve D makes at each movement one-eighth of a revolution only, because the abutments of the teeth of the wheel E occupy positions which are midway of the length of the teeth of the ratchet-wheel F; but any other number of ratchet-teeth may be employed to suit the requirements of the case.

The valve-cage b^2 has a screw-thread, G, at a suitable place near the top, whereby it may be fastened to the lower part, h , of the piston H, as seen in Fig. 7.

In Fig. 7 I have illustrated the application of my invention to an oil-well pump. The piston H therein may be an ordinary single-stroke pump-piston, adapted for lifting oil, and operated by a rod, I.

In Fig. 8 my improved ratchet-valve is shown applied as a check or foot valve of a pump. The valve-cage b^2 is, in this instance, without side openings, but has a number of openings, d^2 , around its ratchets E' F. To the top of this valve-cage a valve-chamber, b^3 , is fastened,

and in the same a ball-valve, D', is applied. Top openings, g , and a screw-top, G, are provided in and on this valve-chamber. The valve-case B, thus modified, is inserted into the pump-barrel and finds its way down to the foot of it before the working or suction piston H is inserted, and, when down to its place, remains firmly seated by reason of the friction of the packing b . When this foot-valve is to be removed the piston H is let down on it, and the cage h screwed upon the head G, whereupon the piston and foot-valve can be hoisted together.

The stem d of the valve D is provided with a cross-shaped elongation, d^4 , which serves to keep the ball D' elevated from its seat when the valve D is elevated by means of the ratchets E' F', and thus permits the oil to be forced down into the oil-well in the manner herein described. The ball-valve D' is used in muddy or sandy oil-wells, where the flat valve D alone would occasionally be prevented by hard substances from closing its seat perfectly. This ball-valve D', by reason of its seat being inclined, does not meet with the same difficulty, and by perfectly closing prevents leakage of oil through the valve D.

In Fig. 9 the valve-case B is substituted by an annular valve-seat, B', to which a tubular valve-cage, b^2 , is fastened, which valve-cage is attached to the foot of the pump-barrel A, wherein an ordinary piston, H, is contained. The parts B' b^2 are of much greater diameter than the barrel A, and the ratchets E' F' E F may have a great number of teeth, so that the valve shall not make a full revolution when the piston has made only four strokes, as in the plan shown in Figs. 1, 2, &c. The annulus B' may in this case be provided with passages C¹ C², for special down and sidewise discharges, and the valve D may be provided with more than one registering-hole, e^2 .

Operation: Referring particularly to Fig. 7 of the drawings, it will be seen that the upward stroke of the piston H effects an enlargement of the space between the foot-valve and piston H, and that a vacuum is caused and a rush of oil through the valve-case B takes place. This causes the valve D to be lifted and thrown with its ratchet-wheel E against the ratchet-wheel F of the valve-cage b^2 . When the ratchet-wheels meet, the vertical abutments of their teeth stand apart laterally, and the violence of the thrust causes the teeth of the ratchet-wheel E to slide up under the inclined sides of the teeth of the wheel F until their abutments match, as shown in Fig. 3, and thus the valve will have been slightly turned from its former position, or, as shown in the drawings, about one-eighth of a revolution.

At the beginning of the downstroke the valve drops down toward its seat; but before it arrives there the teeth f come in contact and match with the inclined sides of the teeth e^1 , slide along the said inclination, and finally drop into the notches e^2 , whereby the valve is permitted to drop upon its seat, and the abut-

ments of the teeth of ratchet E are moved midway of the length of the teeth of the ratchet F, ready for another one-eighth of a revolution.

During the downstroke the space between the foot-valve D and piston H is gradually diminished, and the oil therein forced through the upper piston, H, to be discharged from the pump by the next stroke; and with the next upstroke of the piston H the valve is again lifted and partly turned, as in the preceding downstroke, and oil enters the gradually-enlarged space between the piston H and valve D, and the next downstroke causes the valve to drop with its elongated teeth *f* upon the teeth *e* (which are not notched) of the wheel E', along the inclination of which they slide down until stopped by their vertical abutments.

By this operation the valve is prevented from settling upon its seat, and is kept suspended during the downstroke at a little distance above the seat, and in consequence thereof the oil which has been lifted above the valve is forced through the valve-seat of case B into the oil-well; and by this means the oil, paraffine, and other substances in the well are very violently agitated and the flow of the well insured, and at the same time a part of the oil between the piston H and valve D is caused to find its way through the passage C¹ of the valve-case B to the groove *c*, and out through the holes *a* in the well-tube or pump-barrel, in range with the groove, and thus a number of radial jets forcibly enter the oil-well at quick intervals of time and wash the paraffine from its sides.

Having described my invention, I claim—

1. An oil-well pump provided with a valve, D, constructed and operating substantially as described, whereby the major portion of the oil or other fluid is lifted and discharged at the top of the well, and at intervals a portion

of the oil lifted is forcibly returned in a vertical direction, or both in a vertical and lateral direction, into the oil-well, and the horizontal or lateral discharges effected from time to time independently of the vertical ones, as and for the purposes set forth.

2. The combination of a spindle-valve, a hollow or vertically-perforated foot-valve, and the double-ratchet mechanism, whereby a portion of the oil which has been raised above the valve can be forcibly discharged down through the foot-valve into the well, substantially as and for the purpose described.

3. The combination of a lateral discharge passage or passages leading from the seat of the valve through the case, or to the periphery of the same, and a spindle-valve provided with the double-ratchet mechanism, whereby a portion of the lifted oil is returned forcibly down through the valve-case and discharged against the sides of the well, while another portion is discharged vertically through the valve-case into the well-bottom, substantially as and for the purposes set forth.

4. The combination of a valve having an opening or openings, and provided with the double-ratchet mechanism, and a vertically and laterally perforated valve-case, whereby when the valve is not lifted, but fully down upon its seat, a communication through the valve with the lateral passage or passages is secured once (or oftener) during the revolution of the valve, substantially as described, and for the purpose set forth.

Witness my hand, in the matter of my application for a patent on an oil-well pump, this 12th day of July, A. D. 1878.

MURDICK LYTTLE.

Witnesses:

JAMES W. JACOBS,
GEORGE ROSS.