

W. B. ALLEN.
Bag-Holder.

No. 206,915.

Patented Aug. 13, 1878.

Fig. 1.

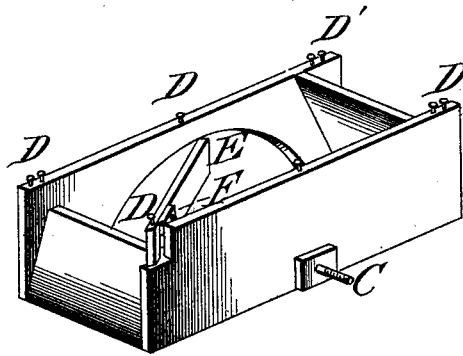
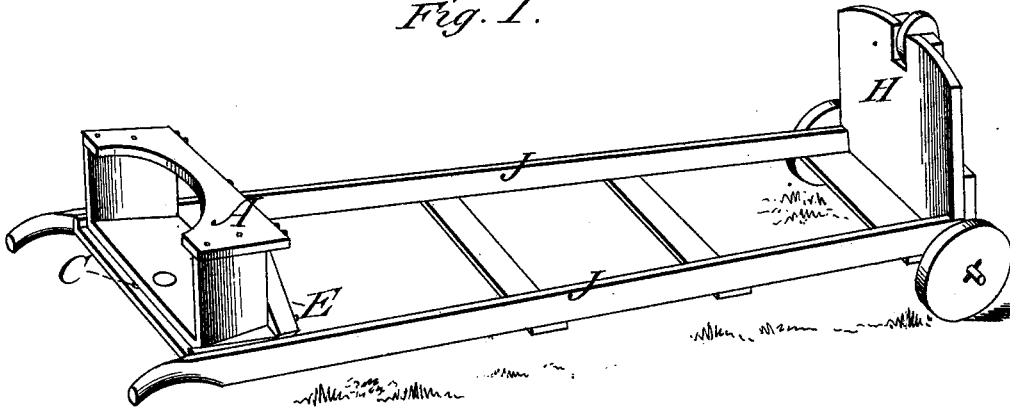

Fig. 2.

Attest.

*Joseph Prescott
S. Culver*

Inventor.

William B. Allen

UNITED STATES PATENT OFFICE.

WILLIAM B. ALLEN, OF ORLEANS, NEW YORK.

IMPROVEMENT IN BAG-HOLDERS.

Specification forming part of Letters Patent No. **206,915**, dated August 13, 1878; application filed October 3, 1877.

To all whom it may concern:

Be it known that I, WILLIAM B. ALLEN, of Orleans, in the county of Ontario and State of New York, have invented a new and useful Improvement in Bag-Holder, Hopper, and Conveyer combined, which improvement is fully set forth in the following specification and drawings, in which—

Figure 1 is a perspective view of the hopper, holder, and conveyer connected and ready for use; and Fig. 2 is a view of the hopper and holder disconnected from the conveyer and turned bottom-side up, for the purpose of showing the holder more distinctly.

The object of my invention is to furnish a convenient device by which to hold open the mouth or filling end of a grain bag or sack, and in connection therewith a hopper to conduct the grain from the shovel, basket, or other agent employed in filling, to the opened bag, and a conveyer performing the threefold office of supporting the hopper, sustaining the bag in an upright position, and of bearing the same from the place where filled to any other locality.

In the drawings, A, Fig. 1, is the hopper, made of any convenient depth, the side dimensions being greater in one direction than in the other, for the purpose of adapting it more nearly to the width of shovel or basket or other agent usually employed in filling. The ends or shorter sides are sloped from the upper to the lower edge inwardly for the purpose of reducing the delivering-orifice to dimensions somewhat smaller than the average dimensions of the mouths of grain-bags of the usual size. A portion of the front side is cut out circularly for the purpose of adapting it to circular baskets and other receptacles employed in filling, and for the purpose of preventing spilling by whatever may be used.

A bolt, fitted with head and nut C, Figs. 1 and 2, that may be moved vertically in a slot in the upper girder or slat of the conveyer, as shown in Fig. 1, holds the hopper thereto and permits of its being raised or lowered to correspond with the height of the bags.

The holder is formed by stubs, with heads in the shape of wood-screws, or their equivalents, D D D, Fig. 2, driven into the lower edge of the sides of the hopper and into the swinging section E, Figs. 1 and 2. The bag is held

open and to the hopper by applying the mouth or open end of it to the outside of so many of the stubs as that, when the swinging section E is turned outwardly into position to match or correspond with the end of the hopper, of which it forms a part, it expands the mouth of the bag fully open, and draws the edge of the same tight around the stubs, the heads of which prevent slipping downward.

Bags of ordinary size will be held fully open and in place by being put around the stubs not outside of the lower edge of the ends of the hopper. When the bag is of extra size it may be put around the stubs which are beyond the lower edge of the end pieces, as D', Fig. 2. The section E turns upon a hinge, the under end of which is shown at F, Fig. 2, and the stub in the section is at such distance from the pivot of the hinge as that it expands the bag to the extent of some two inches more, when turned into position, than when turned inwardly against the front side, and so draws the bag tightly around the stubs, though a little less tightly than just before the section is swung fully into place, so that when in position for holding and tightening it keeps its place without requirement of fastenings.

The conveyer consists of the platform H and the supporting-bars J, Fig. 1. The platform is mounted on three wheels, as shown in Fig. 1, two of them being larger than the third, and are applied to the same axle, and are of dimensions sufficient to admit of the conveyer being used as a wheeled trundle in removing the bag. The third wheel is smaller than the others, and is of dimensions sufficient to raise the front of the platform from the floor and to keep the same level. Upon the platform the bag is set when fixed to the holder and being filled.

The bars J, at their lower end, are connected to the platform at right angles, or nearly so, with the plane of its upper surface in the direction of front and rear, and at their upper ends are spread from each other laterally, for the purpose of receiving the hopper between them, as shown in Fig. 1, and are employed for supporting the hopper and holder, sustaining the bag in an upright position, and for moving the platform. The bars are kept in place relatively to each other by means of slats

or girders, as shown in Fig. 1, the upper one being wider than the others for the purpose of admitting a slot to be made therein for the reception of the bolt for attaching the hopper and holder, and of permitting the bolt to be raised or lowered, as the length of the bag might require.

I am aware that vertically-adjustable hoppers have been used in connection with platform-trucks; also that hoppers have been made adapted to distend the mouth of a bag secured thereto, and my invention is restricted to the combination of the particularly-formed parts set forth in the claim.

What I claim, and desire to secure by Letters Patent, is—

In a bag-holder, the combination, with the hopper provided with the swinging section E, which forms part of its end frame, of the inverted vertical studs D, which are fastened to the bottom of its sides and the bottom of said swinging section, substantially as set forth.

WILLIAM B. ALLEN.

Witnesses:

JOEL H. PRESCOTT,
S. CULVER.