

C. H. AMES.
Fire-Escape.

No. 206,916.

Patented Aug. 13, 1878.

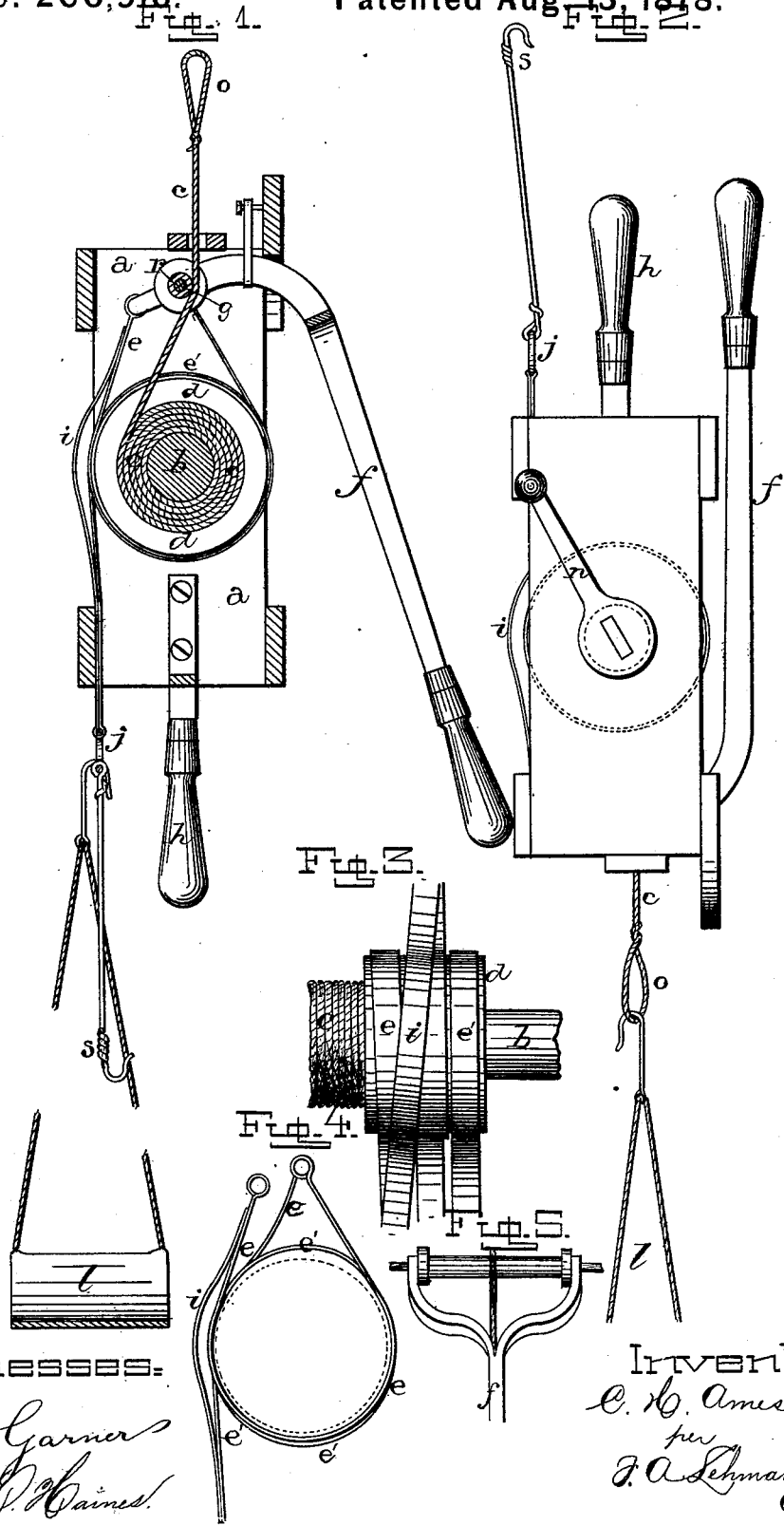

Witnesses:

J. W. Garner
H. S. D. Barnes

Inventor:

C. H. Ames,
per
J. A. Schmann,
att'y.

UNITED STATES PATENT OFFICE.

CHARLES H. AMES, OF UNION CITY, PENNSYLVANIA.

IMPROVEMENT IN FIRE-ESCAPES.

Specification forming part of Letters Patent No. 206,916, dated August 13, 1878; application filed July 30, 1878.

To all whom it may concern:

Be it known that I, CHARLES H. AMES, of Union City, in the county of Erie and State of Pennsylvania, have invented certain new and useful Improvements in Fire-Escapes; and I do hereby declare the following to be a full, clear, and exact description of the invention, such as will enable others skilled in the art to which it pertains to make and use it, reference being had to the accompanying drawings, which form part of this specification.

My invention relates to an improvement in fire-escapes; and it consists in the arrangement and combination of a drum upon which the wire rope or fire-proof cord is wound, an operating-lever, and double-acting brakes, whereby a person can first lower others, then reverse it and lower himself, as will be more fully described hereinafter.

Figure 1 is a vertical section of my invention. Fig. 2 is a side elevation of the same, and Fig. 3 is a detail. Fig. 4 is a side view of the brakes alone. Fig. 5 is a detail view of the operating-lever.

a represents a suitable frame-work, in which is journaled the windlass *b*, upon which the wire rope or fire-proof cord *c* is wound. This windlass or shaft is enlarged at each end, so as to form the drums *d*, around which pass the brakes *e e'*, for the purpose of regulating the rapidity of the descent from the burning building. Passing through the frame, at some distance above the windlass *b*, is the rod *g*, upon which is pivoted the pronged operating-lever *f*, by means of which the brakes are operated. The pronged ends of the lever extend a short distance beyond the rod *g*, and have the brakes *e* attached to them, while the long end extends down below the bottom edge of the frame, and has a handle secured to it, so as to be used in conjunction with the fixed handle *h* secured to the bottom of the frame *a*. The brake *e* consists of a flat steel band, which has one end secured to the short end of the lever, passing down under and around the drum, and has its other end fastened to the rod *g*. When the lower end of the lever *f* is pressed inward toward the fixed handle *h* the short ends of the lever draw the two brakes *e* tightly in contact with the drum, so as to instantly stop the

descent of the frame or check the speed at which it is moving.

Fastened to the outside of the brakes *e*, just below the short ends of the lever, are the bands *i*, which extend down and have their lower ends fastened to the brakes *e'*; or, if preferred, the two brakes *e* and *e'* may be made in one continuous band. The brakes *e'* have their upper ends fastened to the rod *g*, passing once around the drums, and have their lower ends fastened to the rings *j*, to which rings are fastened the stirrup *l*, in which the descending person sits. The weight of the person or persons acts directly upon the brakes *e'*, but does not in any wise affect the brakes *e*.

As the two brakes are connected together by means of the bands *i*, as shown, when the lever *f* is drawn inward at its lower end the brakes *e* are made to clamp the drums at the same time that the bands *i* are drawn upward with such force, by the short ends of the levers, that the whole weight of the descending person or persons is taken from the brakes *e'*, which, being thus freed, at once slacken, so as to exert no pressure whatever upon the drums. When no pressure is exerted upon the lever *f* the weight of the persons in the stirrup draws the brakes *e'* with sufficient friction against the drums to prevent them from descending; but as soon as the lever *f* is operated the bands *i* serve to release all pressure upon the brakes *e'* and transfer it to the brakes *e*.

The operation of my escape is as follows: The wire or fire-proof rope is wound upon the windlass *b* by means of the handle *n* on one end. A loop, *o*, is formed upon the end of this rope, which end is passed up through a hole in the top of the frame, and in order to prevent any unnecessary friction upon this rope a roller, *r*, is placed upon the rod *g* between the prongs of the lever *f*. If more than one person or load is to be lowered, the frame is attached to the window-casing or other suitable object by the hook *s*, with the top of the frame downward, and the stirrup is attached to the end of the rope by the loop *o*. The person or persons to be lowered get into the stirrup, and the operator grasps the fixed handle *h* and the end of the lever *f* with one hand, when, by operating the lever *f*, the load will descend with

any desired rapidity. The operator then winds the rope back upon the windlass, when the machine is again ready for use, and the operator in charge, while remaining at the window, can lower load after load, keeping the descent perfectly under his control. After lowering all the others, he has but to reverse the frame, attach the rope to the window and the stirrup to the rings *j*, when he can lower himself and the machine at the same time, detach the rope from the windlass, and preserve the machine for future use.

As the weight of the person or load in the stirrup acts directly upon the brakes *e'* when the lever *f* is not operated, should the operator's hand accidentally slip off from the lever, or should he, from any cause, let go of it, all descent will at once be stopped, and the person or load, or the operator himself, if he is descending, will remain suspended in the air until he again gets hold of the lever and operates it.

Having thus described my invention, I claim and desire to secure by Letters Patent—

1. The combination of the windlass having the drums on its ends, an operating-lever, and two sets of brakes that are connected together by bands *i*, substantially as shown.

2. The combination of the two sets of brakes, connected together by the bands *i*, whereby either set may be brought into action, substantially as described.

3. The combination of the rope, windlass, two sets of brakes, lever *f*, handle *h*, and hook *s*, substantially as described and set forth.

In testimony that I claim the foregoing I have hereunto set my hand and seal this 24th day of July, 1878.

CHARLES H. AMES. [L. S.]

Witnesses:

H. D. PERSONS,
S. M. HAYES.