

L. J. ATWOOD.
Lantern.

No. 206,918.

Patented Aug. 13, 1878.

Fig. 1.

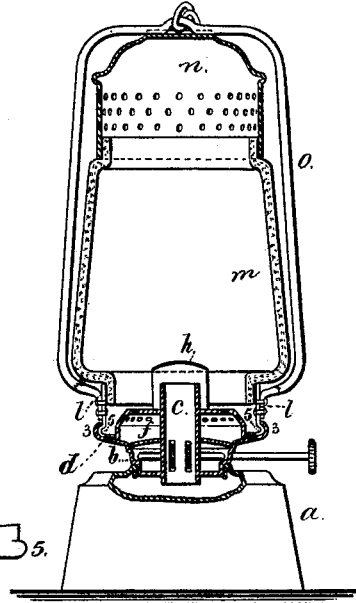

Fig. 5.

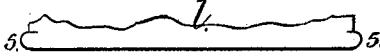

Fig. 4.

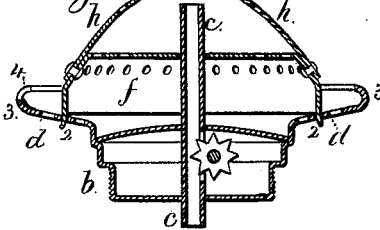

Fig. 2.

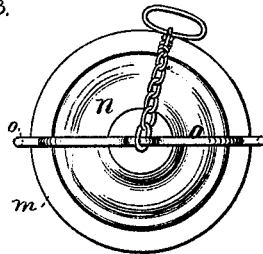
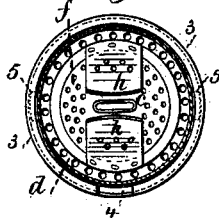

Fig. 3.



Witnesses

Chas. H. Smith
Geo. D. Pinckney

Inventor

Lewis J. Atwood.

per Samuel W. Percell

att'y.

UNITED STATES PATENT OFFICE.

LEWIS J. ATWOOD, OF WATERBURY, CONNECTICUT, ASSIGNOR TO THE
PLUME & ATWOOD MANUFACTURING COMPANY, OF SAME PLACE.

IMPROVEMENT IN LANTERNS.

Specification forming part of Letters Patent No. **206,918**, dated August 13, 1878; application filed
June 20, 1878.

To all whom it may concern:

Be it known that I, LEWIS J. ATWOOD, of Waterbury, in the county of New Haven and State of Connecticut, have invented an Improvement in Lanterns, of which the following is a specification:

Lanterns have been made with a glass and its frame connected to the base of the lantern by bayonet-locking studs and slots.

One feature of my invention relates to a peculiar construction of bayonet-lock at the edge of the air-distributor.

The top of the lantern has been detachable from the glass, and metallic tops to lantern-chimneys have been held in place by springs, as in my Patent No. 129,509, granted July 16, 1872.

Another feature of improvement in my present lantern relates to a spring-bail that serves the twofold purpose of holding the glass and metallic top in place and of suspending the lantern by a chain or ring connected to such bail.

In the drawings, Figure 1 is a vertical section of the lantern. Fig. 2 is a plan of the same. Fig. 3 is a sectional plan of the bayonet-lock. Fig. 4 is a section of the burner detached, and Fig. 5 is an elevation of the lower part of the chimney-holder.

The reservoir *a* receives the base *b* of the burner. *c* is the wick-tube; *d*, the air-distributor around the base, adjacent to the ratchet-cap. *f* is a supplemental air-distributor surrounding the wick-tube, and having a flat or nearly flat upper surface and conical sides, which are perforated with numerous holes. This is removable from the air-distributor *d*, but when in use it rests upon such air-distributor, and is held by tongues 2 2 that pass through mortises in such air-distributor. The plates *h* are fastened upon the conical sides of the supplemental air-distributor *f*, and stand at an inclination toward each other, so that their upper ends are near each other above the wick-tube, and serve to direct air upon the flame. There are holes through these deflecting-plates *h*.

The edge of the air-distributor is turned up as a flange, 3, and contracted at the upper part to form a nearly-semicircular recess, and the ring *l* of the chimney or glass holder sits within this flange 3, and it is provided with ribs 5 at opposite sides, formed by striking up the metal in a die. Such ribs fit the semi-circular recess of the flange 3, and this flange 3 is removed or notched at 4, so that the ring *l* can be set within the flange 3, one of the ribs 5 being set beneath the recessed edge of the flange 3, and the other rib being entered at this notch, so that the parts will be securely connected by giving the ring *l* a partial revolution. The reverse motion separates this peculiarly-constructed bayonet-lock.

The glass *m* rests upon this ring *l*, and its base-flange passes into the same, and there is a metal cap, *n*, resting upon the top of this glass.

The spring-bail *o* is fastened securely at the bottom end to this ring *l*, and the upper end crosses above the cap *n* and rests within the groove of the same, and there is a loop or ring bent in the wire or secured to the same at the center of the bail for the reception of a chain or hoop for suspending the lantern. Guard-rings may be added to the bail *o*.

In placing the parts together the metal top is set upon the glass, and then the glass is placed upon the ring *l* and the bail sprung over the top of the lantern, or it is removed by a reverse motion. The bail-wire, not being straight, and bearing at the central part upon the cap *n*, has sufficient spring to allow of this being done; and hence any special provisions of catches or locking devices for holding the glass to the frame are dispensed with.

I am aware that a stationary wire has been used to hold the glass in place, the base upon which the glass rests being made to rock as the glass is entered or removed.

I claim as my invention—

1. The spring-bail *o*, attached rigidly at its lower end to the ring *l*, upon which the glass *m* rests, in combination with said glass

m and cap *n*, in which cap is a recess for the spring-bail *o*, as and for the purposes set forth.

2. The recessed flange 3 around the edge of the air-distributor, notched, in combination with the ring *l* and the projecting ribs thereon, substantially as set forth.

3. In a lantern-burner, the combination of

the air-distributor *d*, the removable supplemental air-distributor *f*, deflecting-plates *h*, ring *l*, and glass *m*, substantially as set forth.

Signed by me this 15th day of June, 1878.

L. J. ATWOOD.

Witnesses:

ROBT. T. LATTIN,

CHARLES H. SAWN.