

S. SQUIRES.  
Sofa-Bed.

No. 206,980.

Patented Aug. 13, 1878.

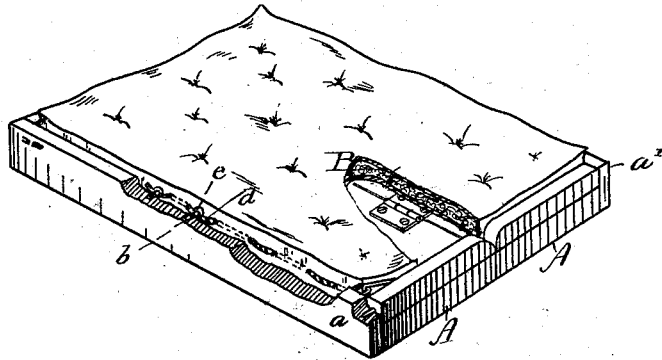

Fig. 1.

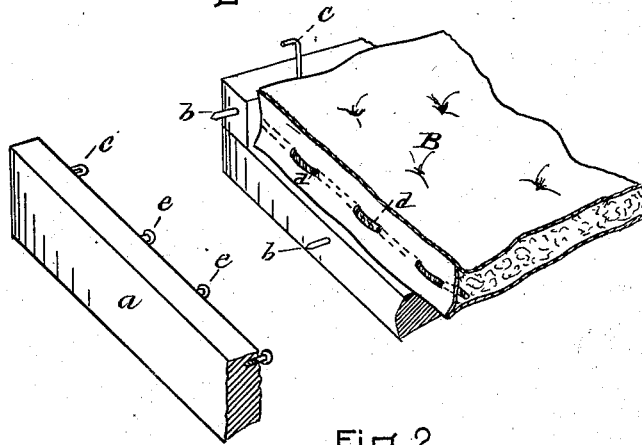

Fig. 2.



Fig. 3.

WITNESSES

*E. C. F. Jamieson*  
*C. A. Wood*

INVENTOR

*Sidney Squires*

# UNITED STATES PATENT OFFICE.

SIDNEY SQUIRES, OF BOSTON, MASSACHUSETTS.

## IMPROVEMENT IN SOFA-BEDS.

Specification forming part of Letters Patent No. 206,980, dated August 13, 1878; application filed April 22, 1878.

*To all whom it may concern:*

Be it known that I, SIDNEY SQUIRES, of Boston, in the county of Suffolk and State of Massachusetts, have invented an Improvement in Sofa-Beds, of which the following is a specification:

The objects of this invention consist, first, in the described means for fastening the mattress forming the seat and back of the sofa-bed to the frame supporting it, for the purposes hereinafter set forth; second, in the manner set forth for securing the front and rear rail of the mattress-supporting frame in place, for the reasons hereinafter given.

In the drawing, Figure 1 is a perspective of the mattress and frame, with the front rail of the frame partially broken out to show the manner of fastening the mattress in place. Fig. 2 is a perspective, showing the front rail removed to expose the method employed in fastening it to the rest of the frame; and Fig. 3 is a partial cross-section to more fully show the construction described.

The frame A is hinged at the center of its width in order that that portion forming the back of the sofa-bed may be lifted when necessary, and is further provided with the removable rails *a a'*, which are fastened to the end and bottom of the frame by means of dowels *b* and hooks and staples *c*.

The mattress B has its sides adjacent to the removable rail provided with the ropes so in-

terwoven as to form the loops *d*, which correspond in place with the projecting buttons or hooks *e* on the inner sides of the rails, to which they are fastened by catching or looping on the same in the manner shown in Fig. 3.

This mode of construction is cheap, simple, and effective for the purpose for which it is designed.

It will be seen that the mattress can be removed with ease and facility, and may be reversed when desired.

It will also be observed that by the easy removal of the rail the frame can be readily cleaned—a very desirable construction for this class of furniture.

I claim and desire to secure by Letters Patent of the United States—

1. In a sofa-bed, the combination of the frame A with the removable rails *a a'*, substantially as described.

2. In a sofa-bed, the combination of a mattress, B, provided with rope-loops *d*, formed by passing a rope in and out the side of the mattress, as shown, at or near the center of its thickness, the buttons or hooks *e* projecting inwardly from the inner side of the removable rails *a a'* and the hinged frame A, substantially as and for the purpose set forth.

SIDNEY SQUIRES.

Witnesses:

E. C. F. SANCHEZ,  
C. AVERA.