

E. S. YOUNG & G. H. DIMOND.  
Sewing-Machine.

No. 206,992.

Patented Aug. 13, 1878.

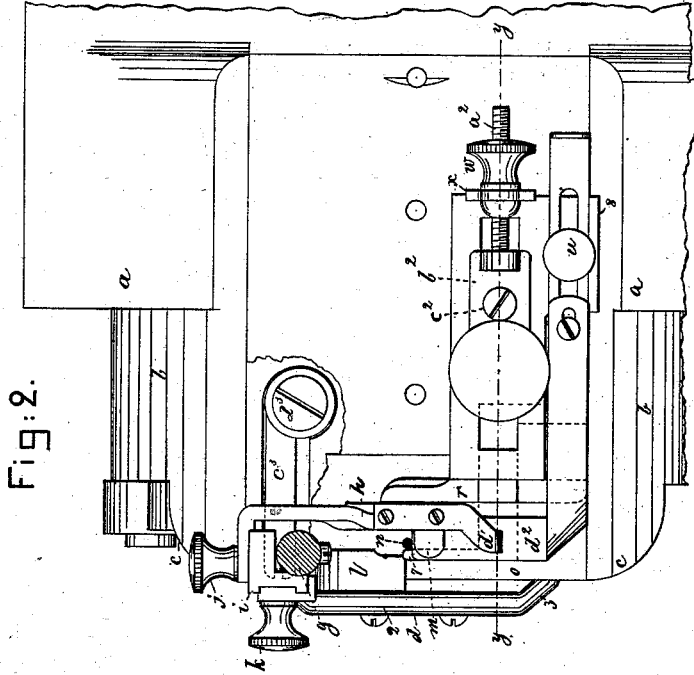

Fig. 2.

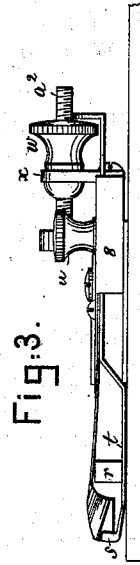

Fig. 3.

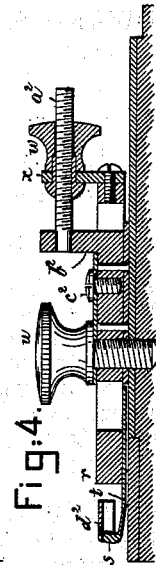

Fig. 4.

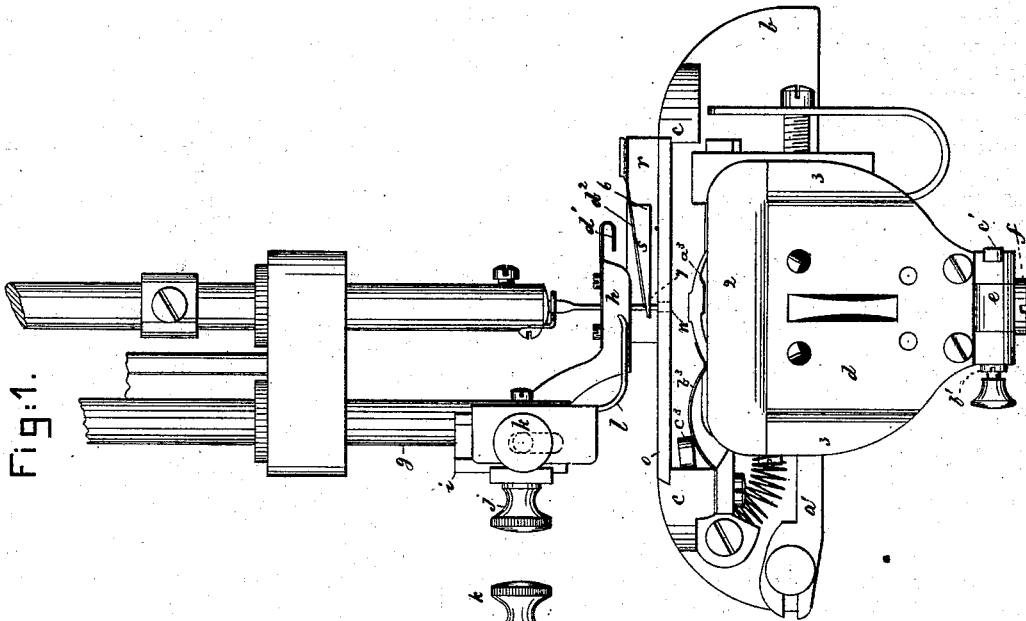

Fig. 1.

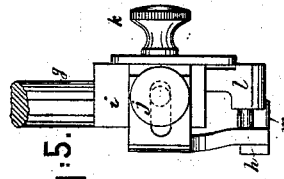

Fig. 5.

Witnesses.  
*L. F. Connor*  
*N. B. Whitney.*

Inventors  
*Edward S. Young & Geo. H. Dimond*  
*by Corroby & Gregory Attys*

# UNITED STATES PATENT OFFICE.

EDWARD S. YOUNG, OF WESTBOROUGH, MASSACHUSETTS, AND GEORGE H. DIMOND, OF BRIDGEPORT, CONNECTICUT.

## IMPROVEMENT IN SEWING-MACHINES.

Specification forming part of Letters Patent No. 206,992, dated August 13, 1878; application filed May 20, 1878.

*To all whom it may concern:*

Be it known that we, EDWARD S. YOUNG, of Westborough, in the county of Worcester, State of Massachusetts, and GEORGE H. DIMOND, of Bridgeport, county of Fairfield, State of Connecticut, have invented an Improved Sewing-Machine, of which the following is a specification:

This invention relates to improvements in sewing-machines; and is specially adapted for uniting braid straw and other braid in the manufacture of head-coverings; and has for its object to adapt the well-known Wheeler & Wilson machine for such sewing.

The invention consists in the combination, in a braid-sewing machine, of the following instrumentalities, viz: A throat-plate, a guide to embrace both edges of the braid being delivered to be stitched, means to adjust such guide laterally with relation to the needle-hole, a guide connected with the presser-shank and made laterally-adjustable with reference to the presser-foot and needle-hole, the adjustment of the upper and lower guide with relation to the needle-hole and each other regulating the amount of lap of the braid being delivered under the edge of the superimposed braid already stitched to form a part of the head-covering, substantially as hereinafter described.

With the devices above mentioned there is employed a presser-foot adjustable vertically upon its bar, and also with such devices for controlling the lapping of the braid there is employed a separator to keep the superimposed braid from liability of passing under the uppermost gage, or below or in contact with the edge of the under braid.

Also, in the combination, with the guide attached to the presser-foot bar, of a separator and a holding-down finger located thereon in advance of the needle-hole in the throat-plate.

Figure 1 represents, in front elevation, a sufficient portion of a sewing-machine to represent this invention; Fig. 2, a top view of the front end of the bed-plate, the overhanging arm being broken away; Fig. 3, a front-edge view of the braid-guide; Fig. 4, a section of the guide on lines *y y*, Fig. 2; and Fig. 5, a rear side elevation showing the connection of the gage and presser with the presser-foot bar.

The machine herein shown is one of the well-known No. 8 Wheeler & Wilson. Its stitch-

forming parts are too well known to need description.

The forward portion of the bed or frame *a* is cut away, as at *b c*, the portion *c* being made as short in the direction of the width of the frame as will permit the movement under it of the feed-bar *a'*. The bobbin is retained in the recess at the front of the usual rotating hook by means of a combined bobbin-holder and hook-shield, *d*, having a rounded flange, *2*, at its top, and also at its side, as at *3*, or at both sides, to prevent the head-covering or portions of it, after the formation of the tip, or as the crown is being commenced, from coming in contact with the rotating hook and feed-bar. This holder or shield is also essential in machines of this kind when employed to stitch sweat-linings into hats and bands upon hats, and also when binding hats.

The holder and shield are shown attached to an adjustable block, *e*, the latter being held in place by a screw, *f*; and the portion *d* is also shown as pivoted to *e* at *b'*, and held upright by a locking-spring or finger, *e'*, as in another application for patent made by George H. Dimond, and filed in the United States Patent Office April 29, 1878.

The presser-foot bar *g* has at one side of it the gage *h* for the inner edge of the upper braid, such gage being held adjustably upon a block, *i*, by a thumb-screw, *j*; and adjustably attached to this same block, by a thumb-screw, *k*, is a presser-foot, *l*. This gage *h* bears upon the braid which is passing from the reel just after it is sewed, such braid passing under it, and at one side of such gage is a separator, *m*, which extends under the upper braid already sewed into coil as part of a head-covering, and prevents the inner edge of such braid being guided by the side or vertical face of the gage *h* from passing under such gage or under the edge of the lower braid.

The needle-hole *n* in the throat-plate *o* is the point from or with relation to which the gages for the inner edge of the upper braid and the inner and outer edges of the lower braid are adjusted so as to cause the needle to penetrate each layer of such braids at a greater or less distance from their centers, and consequently regulate the distance that one braid shall lap or extend over the other.

The upper gage, *h*, by its adjustment toward

or from the inner edge of the needle-hole, regulates the distance from the inner edge of the upper braid at which the needle shall penetrate it, and by adjusting the presser-foot up or down it is adapted to braids of different thickness. This gage *h* is also shown as provided with a holding-down finger, *d*<sup>1</sup>, to keep the upper layer of braid from moving laterally over and across the top of the gage *h*.

The under braid is led from a suitable reel through the lower gage, such braid passing between the main gage *r*, which acts against its inner edge, and the auxiliary gage *s*, which acts against its outer edge. The auxiliary gage *s* is tapered from its head 6 to its point 7, located at or near the needle-hole, so that the upper braid, as it is fed forward, (it then resting above or upon the surface of such gage *s*;) is permitted to bear at its under side directly against the top of the under braid and to rest flat thereon, so that the two braids may be in contact just before being stitched, which permits the two braids to be held closely in such position as the stitch is drawn taut.

In operation, the lower edge of gage *s* bears upon the throat-plate and bed. This gage *s* forms part of a spring-bar, *t*, held upon the portion 8 of the main gage-block by a screw, *u*, and by moving such bar the gage *s* may be adjusted toward or from the main gage *r*, so as to adapt such gages *r s* to bear upon both the inner and outer edges of the under braid coming from the usual reel. When the two gages are made to fit the two edges of the lower braid, then, by means of the thumb-nut *w* (held in lug *x* so that it can only rotate) acting upon the screw *a*<sup>2</sup> secured to the stationary block *b*<sup>2</sup>, held fixedly to the bed by the thumb-screw *c*<sup>2</sup>, the two gages *r s*, with the braid, may be adjusted laterally with relation to the needle-hole, so as to place the inner edge of the under braid at such distance beyond or outside such needle-hole in the throat-plate as it is desired that the needle should penetrate the braid back from such edge, the outer edge of such under braid extending under the inner edge of the upper braid and being lapped more or less, as may be desired.

Attached to or so as to be moved laterally with the auxiliary gage *s* is a pressing-spring, *d*<sup>2</sup>, which rests above the top of the under braid, near the gage *s*, and extends forward to, at, or near the needle-hole, such spring *d*<sup>2</sup> also acting, as does the piece *m*, for a separator.

The braid to be manufactured into a hat is first bent into circular form, to make a circular piece from one to two inches in diameter, it serving as the center of the tip. Then the edge of such center-piece is placed above the separator *m* and against the face of the upper gage, it being held inside the needle-hole. Then the main portion of the strip coming from the reel (such braid forming the under strip) is placed between the gages *r* and *s*,

with the outer edge of the under braid below the inner edge of the center-piece, and then, as the feed operates, the braids, properly lapped, are presented to the action of the needle, so that it penetrates through and through both of the braids, and the stitch is completed in the usual way. After a circular piece large enough for the entire tip of the hat has been formed, such circular piece is tipped over so as to stand in substantially a vertical position with reference to the frame or bed *a*, and in such position is rotated about a horizontal axis until the braids are stitched to form a tubular body of the proper length, and then the tip of the crown is again placed in a horizontal position, and the brim is formed.

The tension-finger *a*<sup>3</sup> for the bobbin or under thread to operate, as in the Wheeler & Wilson machine, has a spring, *b*<sup>3</sup>, bearing upon it, the pressure or force of which is regulated by turning the lever *c*<sup>3</sup>, pivoted at *d*<sup>3</sup>, the lever being held in place by friction between the pivoted end and the bed or other part next the pivot of such arm.

We claim—

1. In a braid-sewing machine, the combination, with the throat-plate and a guide to embrace both edges of the braid being delivered to be stitched, and means to adjust such guide laterally with relation to the needle-hole, of a guide connected with the presser-shank, and made laterally adjustable with reference to the presser-foot and needle-hole, the adjustment of the upper and lower guide with relation to the needle-hole and each other regulating the amount of lap of the braid being delivered under the edge of the superimposed braid already stitched to form a part of the head covering, substantially as described.

2. The presser-bar and its laterally-attached guide *h* for the upper braid, combined with the presser-foot *l*, made vertically adjustable upon said bar and with reference to the guide, substantially as and for the purpose described.

3. The presser-bar, presser-foot *l*, and the guide *h*, to govern the edge of the upper piece of braid, and the independently-adjustable guides *r s*, movable over the bed-plate *a* to control the under braid, combined with a separator, *m*, to keep the two braids apart just in advance of the point where the needle penetrates through them, substantially as described.

4. The presser-foot bar and its attached guide for the edge of the upper braid, combined with the separator and holding-down finger, substantially as and for the purpose described.

EDWARD S. YOUNG.  
GEORGE H. DIMOND.

Witnesses to signature of E. S. Young:

A. G. BISCOE,  
J. W. FAIRBANKS.

Witnesses to signature of Geo. H. Dimond:

F. HURD,  
A. R. LACEY.