

W. E. BARKER.
Quilting-Frame.

No. 207,000.

Patented Aug. 13, 1878.

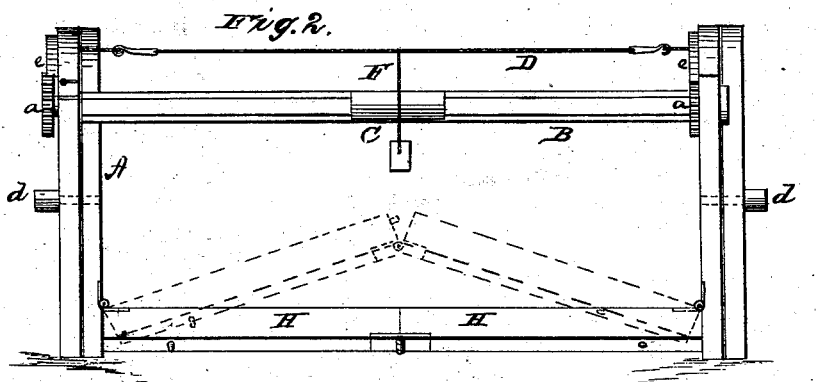
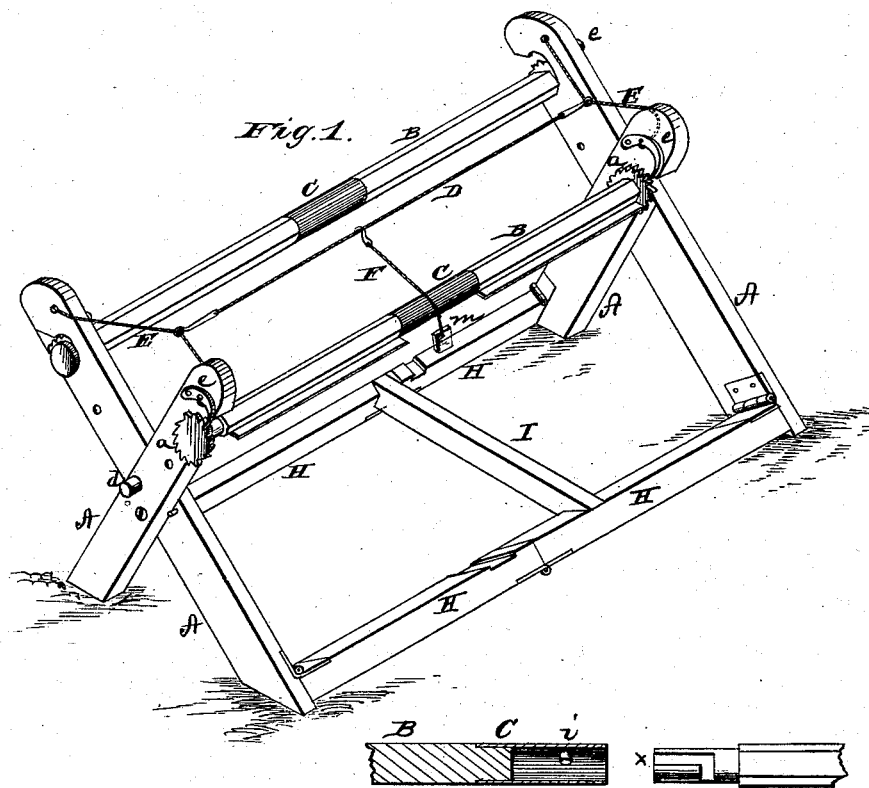

WITNESSES
F. L. Curand
Haukhaat

By

INVENTOR
W. E. Barker
Alexander Inneson
Attorneys

UNITED STATES PATENT OFFICE.

WESLEY E. BARKER, OF UTICA, KENTUCKY.

IMPROVEMENT IN QUILTING-FRAMES.

Specification forming part of Letters Patent No. 207,000, dated August 13, 1878; application filed June 26, 1878.

To all whom it may concern:

Be it known that I, WESLEY E. BARKER, of Utica, in the county of Daviess, and in the State of Kentucky, have invented certain new and useful Improvements in Quilting-Frames; and do hereby declare that the following is a full, clear, and exact description thereof, reference being had to the accompanying drawings, and to the letters of reference marked thereon, making a part of this specification.

The nature of my invention consists in the construction and arrangement of the several parts of a folding and adjustable quilting-frame, the peculiarities of which will be hereinafter set forth.

To enable those skilled in the art to make and use my invention, I will proceed to describe its construction and operation.

In the accompanying drawings, making part of this specification, Figure 1 represents a perspective of my frame, and Fig. 2 a side view of same.

In the drawings, A A represent the two legs at each end of the frame, which are crossed and pivoted together at their crossing. Near the upper ends of these legs, and in their outer edges, are cut openings, to form bearings for the shafts B B. The shafts B B are provided with suitable strips of cloth, to which the ends of the material to be quilted are secured, and are also made in two parts, so that they can be made to occupy small compass in case of transportation. A sleeve, C, covers the joint at the center of the shafts. An L-shaped groove, *x*, is formed on one end, and a pin, *i*, is used in the sleeve *i'*, and which fits into the groove *x*, for the purpose of connecting the two inner ends of the jointed shafts B B. Each end of the shafts B B is provided with a ratchet-wheel, *a*. Upon the legs A A, and above the ratchet-wheels, are pawls *e e*, which catch into said wheels and hold them in position.

E E represent cords, which pass through the upper ends of the legs A A and connect with the pawls *e e*. These cords E E are connected together at their centers by a cord, D, which runs longitudinally of the frame, and to the center of the cord D is a cord, F, to the end of which is a weight, *m*.

The operator, while sitting about the center

and at one side of the frame, may draw the cord F, and, through the other cords, raise the pawls from the ratchet-wheels, thus enabling the shafts or rollers B B to be turned for unwinding and winding up the material to be quilted. The weight, when dropped over one side, as seen in the figures, holds the pawls up. When they are to be dropped the weight is raised and placed upon the quilt.

H H represent braces at the bottoms of the legs. These braces are not only hinged to the legs, but are hinged together at their centers, in order to allow of the folding up of the frame. I represents a detachable cross-brace between the braces H H, for holding them in position. *d d* represent pins, which enter the legs at each end, for the purpose of stationing them when necessary.

When the shafts or rollers B B are removed from the frame, and when the brace I is taken out, the frame can readily be folded together in small compass, the bars or braces H H bending upward, as seen in dotted line, Fig. 2. The shafts B B may also be easily taken apart, and thus the whole frame folded together.

I am aware that it is not new in quilting-frames to use rollers carrying ratchet-wheels and a removable crank-arm, combined with two pawls and a holding-down spring; hence I do not claim such, broadly, as my invention.

Having thus fully described my invention, what I claim as new is—

1. The shafts or rollers B B, provided with ratchet-wheels at each end, in combination with the pawls *e e* and cords E D, and weighted cord F, as and for the purpose set forth.

2. The shafts or rollers B B, jointed at their inner ends and constructed as described, in combination with the sleeves C C, as and for the purpose specified.

3. The combination of the legs A A, the rollers B B, the braces H H, and the brace I, constructed as and for the purpose set forth.

In testimony that I claim the foregoing I have hereunto set my hand this 27th day of April, 1878.

W. E. BARKER.

Witnesses:

H. AUBREY TOULMIN,
GEO. D. MATTINGLY.