

J. E. GOODRICH.  
Window-Blind.

No. 207,027.

Patented Aug. 13, 1878.

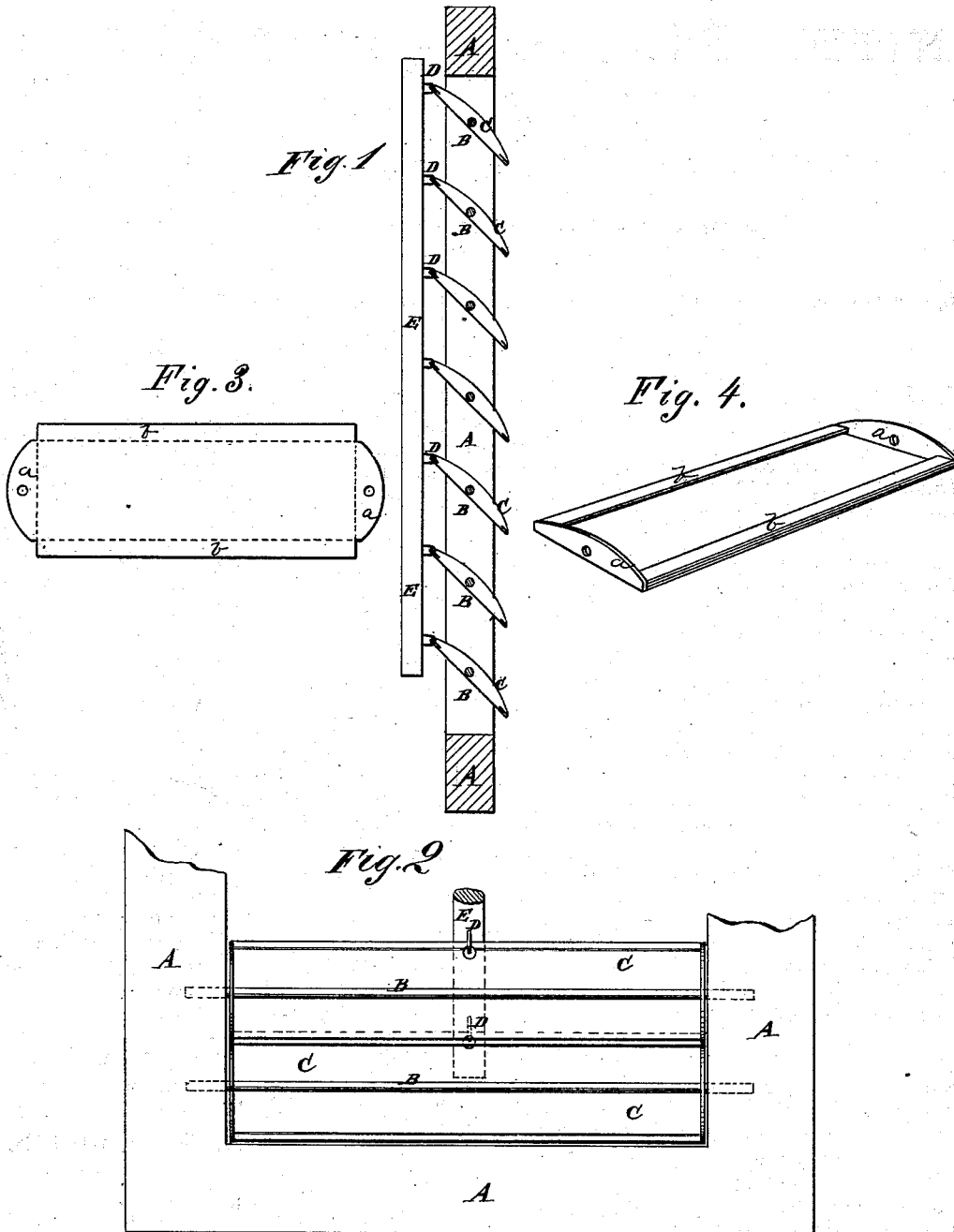

WITNESSES:

*A. W. Almquist*  
*John Coethals*

INVENTOR:

*J. E. Goodrich*  
BY *Munnell*

ATTORNEYS.

# UNITED STATES PATENT OFFICE.

JOHN E. GOODRICH, OF SYCAMORE, OHIO.

## IMPROVEMENT IN WINDOW-BLINDS.

Specification forming part of Letters Patent No. **207,027**, dated August 13, 1878; application filed June 20, 1876.

*To all whom it may concern:*

Be it known that I, JOHN E. GOODRICH, of Sycamore, in the county of Wyandot and State of Ohio, have invented a new and valuable Improvement in Metallic Window-Blinds; and I hereby declare that the following is a full, clear, and exact description of the construction and operation of the same, reference being had to the annexed drawings, forming a part of the specification, and to the letters and figures of reference marked thereon, in which—

Figure 1 is a vertical section of one of my improved blinds, the slats being shown in end view, and Fig. 2 is an outside view of the lower part of one of my improved blinds. Fig. 3 represents a plan view of the blank from which my slat is formed by bending the edges and ends. Fig. 4 is a perspective view of the slat.

Similar letters of reference indicate corresponding parts.

The object of this invention is to furnish window-blinds which will not swell and shrink with changes in temperature, will not be likely to take fire, will require less paint, and will be more durable and less liable to get out of order than when made in the usual way.

The invention will first be described in connection with drawings, and then pointed out in the claim.

A represents the frame of the blind, which is made of wood, and to the side bars of which are attached the ends of as many parallel cross-wires B as there are to be slats C. The slats C are made of sheet-metal from blanks,

as shown in Fig. 3 of the drawings, having curved ends *a* and extended side edges *b*, the side edges of which are bent over to strengthen them, and the end edges whereof are bent inward at right angles, and have holes formed through the flanges to receive the wires B. In the middle parts of the upper edges of the slats C are formed holes to receive the staples D, which are attached to the bar E, so that the slats C may all be turned together, and may always be parallel with each other. The wires B are placed at such a distance apart that the lower edge of each slat may overlap the upper edge of the next lower slat.

By this construction light, strong, and durable blinds will be produced, which will not swell in damp weather, and will be less liable to take fire than the thin wooden slats usually used in blinds.

Having thus described my invention, I claim as new and desire to secure by Letters Patent—

The metallic blind-slat herein described, having its side edges doubled by bending down the side extensions *b* and its curved ends bent at right angles with its plane, its double inside edge being perforated for the passage of the hinge-staple, and its curved ends being made with center holes for the passage of the fulcrum-wire, substantially as shown and described.

JOHN E. GOODRICH.

Witnesses:

MARC E. LYNCH,  
G. W. BILES.