

J. JOHNSON.
Harrow.

No. 207,039.

Patented Aug. 13, 1878.

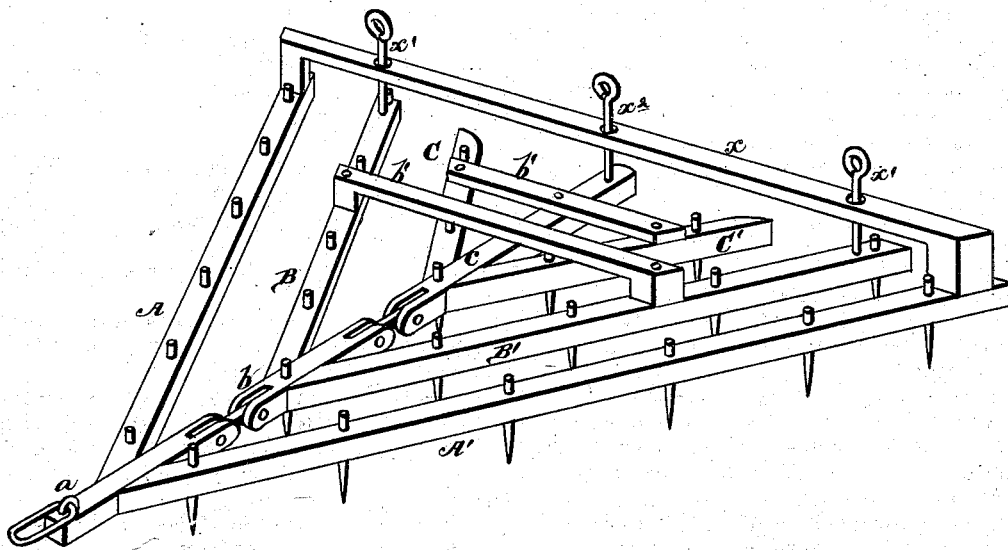

WITNESSES
Robert Emmett
Jas. J. Sheehy

INVENTOR.
Joshua Johnson
Gilmore Smith & Co.
ATTORNEYS.

UNITED STATES PATENT OFFICE.

JOSHUA JOHNSON, OF WILLIAMSTOWN DISTRICT, WOOD COUNTY, WEST VIRGINIA.

IMPROVEMENT IN HARROWS.

Specification forming part of Letters Patent No. 207,039, dated August 13, 1878; application filed July 13, 1878.

To all whom it may concern:

Be it known that I, JOSHUA JOHNSON, of Williamstown District, in the county of Wood and State of West Virginia, have invented a new and valuable Improvement in Harrows; and I do hereby declare that the following is a full, clear, and exact description of the construction and operation of the same, reference being had to the annexed drawing, making a part of this specification, and to the letters and figures of reference marked thereon.

The figure of the drawing is a representation of a perspective of my harrow.

My invention relates to the class of harrows which are jointed to allow for unevenness of surface of ground.

The object of my invention is to provide a jointed harrow, in sections, readily disjointed, and each section capable of being employed independently. When used together the sections are jointed in such a manner as to have free limited movement in any direction, and thus compensate for unevenness of surface of ground.

My invention consists in three detachable triangular sections, of three sizes, adapted to be employed within each other, relatively, from the larger to the smaller. Each section is essentially two sides of a triangle, the vacant side being the rear end of the harrow. A link-bar attaches the two sides at the apex or front of the harrow. This link-bar is common to all the sections, and from these points the sections are loosely connected.

The rear extremities of all the triangles form a common plane, and from these extremities each section is secured to the other with a loose connection, which, while it holds the sections in their relative positions, allows a free vertical adjustment corresponding to the irregularities of the surface of the ground.

Referring to the drawings, A A' represent the larger section, having the link-bar *a*, to which the clevis or other draft-connection is

secured. The bars $\Lambda \Lambda'$ are furnished with the ordinary harrow-teeth, and at their rear extremity a rigid cross-bar, *x*, secures them in position. This cross-bar is provided with loose pins, which attach to the other sections, and serve to keep the sections in their relative positions.

B B' represent the intermediate section, having also the link-bar *b*, secured to the link-bar *a* by a loose connection, provided with ordinary teeth, and loosely secured to the cross-bar *x* by pins *x*¹. A cross-bar, *b*', strengthens the side bars.

C C' represent the smaller section, and *c* the link-bar, loosely secured to the link-bar *b*, as shown, and to the bar *x* by pin *x*².

The sections in my improvement are readily detachable, and may be employed at will, that of C C' as a hand-harrow, that of A A' as a light-draft harrow, and all or any may be used as occasion suggests.

The rear extremities may be secured by links or short chains—*i. e.*, two links between sections A A' and B B', and two between B B' and C C'.

What I claim as new, and desire to secure by Letters Patent, is—

The harrow herein described, consisting of the sections A A', B B', and C C', of triangular form and different sizes, loosely linked together at the forward extremity, as shown, with their rear extremities on the same plane, and loosely secured at such rear extremity to the bar *x*, the whole adapted to be readily detached at will, and to allow free limited vertical motion, as specified.

In testimony that I claim the above I have hereunto subscribed my name in the presence of two witnesses.

JOSHUA JOHNSON.

Witnesses:

GEORGE LOOMIS,
L. N. TAVENNER.