

J. A. TALPEY.  
Machine for Unhairing, Scouring and Currying Hides.  
No. 207,081. Patented Aug. 13, 1878.

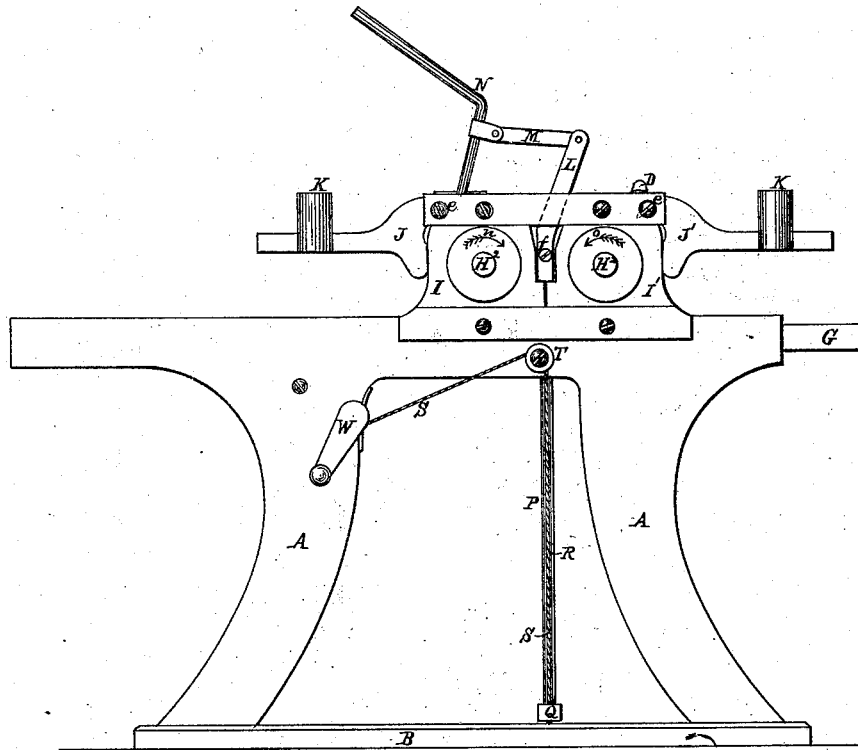

Fig. 2.

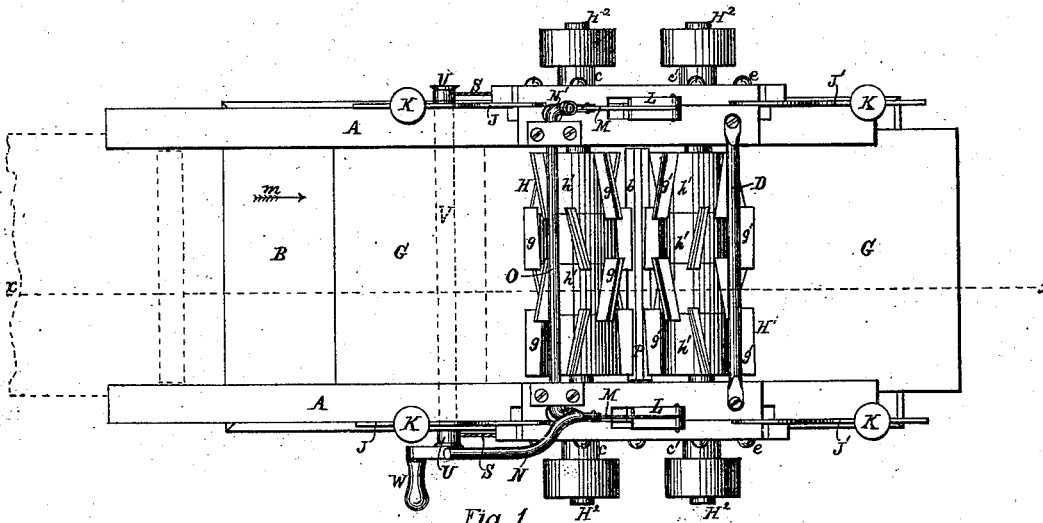

Fig. 1.

Witnesses.  
*E. A. Kemmenway*  
*Benj. Andrews, Jr.*

Inventor.  
*Joseph A. Talpey*  
 by *N. P. Lombard,*  
 Attorney.

J. A. TALPEY.  
Machine for Unhairing, Scouring and Currying Hides.

No. 207,081.

Patented Aug. 13, 1878.

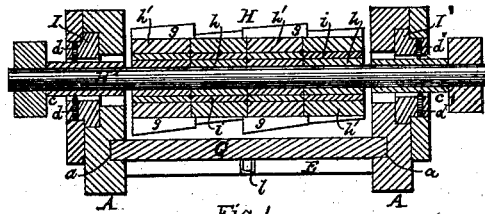

Fig. 4.

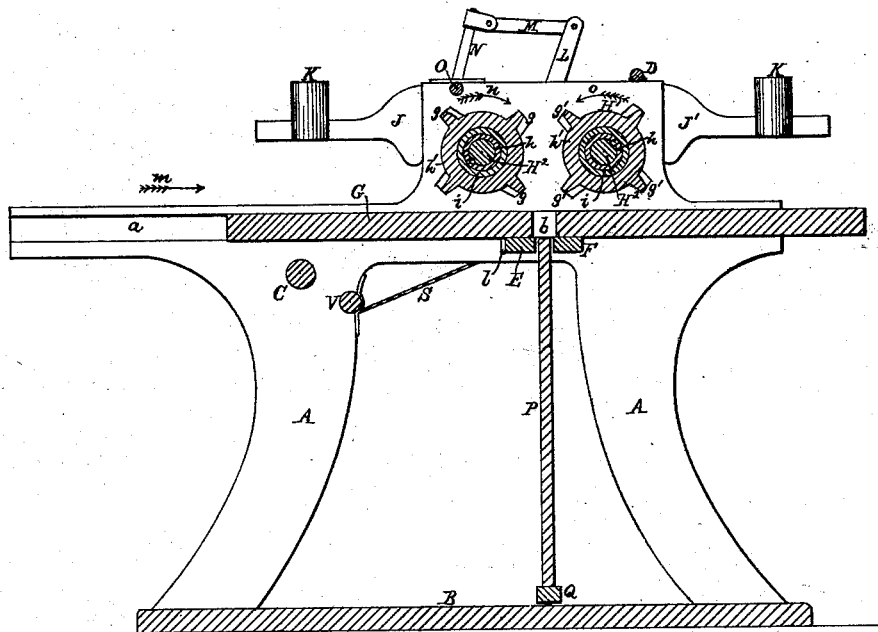

Fig. 3.

Witnesses.  
G. A. Hemmenway  
Benj. Andrews, Jr.

Inventor  
Joseph A. Talpey  
by N. D. Lombard  
Attorney.

# UNITED STATES PATENT OFFICE.

JOSEPH A. TALPEY, OF SOMERVILLE, MASSACHUSETTS.

IMPROVEMENT IN MACHINES FOR UNHAIRING, SCOURING, AND CURRYING HIDES.

Specification forming part of Letters Patent No. 207,081, dated August 13, 1878; application filed February 1, 1878.

*To all whom it may concern:*

Be it known that I, JOSEPH A. TALPEY, of Somerville, in the county of Middlesex and State of Massachusetts, have invented certain new and useful Improvements in Machines for Unhairing, Scouring, and Curryng Hides, of which the following, taken in connection with the accompanying drawings, is a specification.

My invention relates to that class of hide-working machines in which the hide or skin is acted upon by knives or blades arranged upon the periphery of a cylinder and adapted to be brought in contact with the hide or skin as said cylinder revolves, and is an improvement upon the invention described in Letters Patent granted to me January 22, 1878; and it consists, first, in a peculiar construction of the knife-cylinders whereby the said cylinder is rendered, to a certain extent, elastic or susceptible of yielding slightly to the pressure applied thereto while its shaft rotates in fixed bearings, and whereby each section of said cylinder may yield to a certain extent, independent of the other sections, so that the edges of the scrapers or knives may conform to the surface of the hide or skin however its thickness may vary.

My invention further consists in an improved method of mounting the two knife-cylinders in adjustable bearings, whereby they are made to accommodate themselves to the surfaces of the hide upon the carrier-plate when one edge of the hide or skin is considerably thicker than the other.

My invention further consists in the use, in combination with two knife-cylinders mounted in bearings in a position parallel or nearly parallel to each other, and a vertically-reciprocating carrier-plate adapted to feed the hide or skin doubled over its edge between said cylinders, of a table mounted in suitable ways or guides, in which it may be moved endwise in a direction at right angles to the motion of the carrier-plate, and provided with a transverse slot in the middle of its length, through which the carrier-plate may reciprocate, as will be more fully described.

Figure 1 of the drawings is a plan of my improved machine. Fig. 2 is a side elevation. Fig. 3 is a vertical longitudinal section on line *x x* on Fig. 1, and Fig. 4 is a central longi-

tudinal section through one of the knife-cylinders and its bearings.

A A are the two side frames of the machine, connected together by the base-board B and the tie rods or girts C, D, E, and F, and each having formed in its inner face a horizontal groove, *a*, into which is fitted the table G, having in the center of its length the slot *b*, extending transversely of said table, and of a length equal to the width between the frames A A.

H and H<sup>1</sup> are two knife-cylinders, mounted respectively in boxes *c c* and *c' c'*, supported on the screw-pivots *d d* and *d' d'* set in the slides I I and I' I', which slides are fitted to and adapted to be moved horizontally in suitable ways formed in the upper portions of the frames A A.

J J and J' J' are levers, pivoted respectively to the front and rear ends of the upper portions of the frames A A at points marked *e e*, the short arms of said levers bearing against the outer ends of the slides I and I', while the long arms extend horizontally and carry thereon the counter-weights K K, as shown in Figs. 1, 2, and 3. These weights are to be of sufficient weight, and so adjusted that the cylinders H H<sup>1</sup> will be forced toward each other with sufficient pressure to produce the desired action upon the hide or skin as it is moved up between said cylinders.

L L are two levers, each pivoted, as at *f*, to one of the frames A, with its lower end between the slides I and I', and so shaped and arranged relative thereto that a movement of its top end toward the front of the machine will cause the slides I and I', and consequently the cylinders H and H<sup>1</sup>, to be moved away from each other at about an equal rate of speed.

The upper ends of the levers L L are each connected by a link, M, to an arm or lever, N or N', formed upon or secured to the rock-shaft O, mounted in bearings formed in the frames A, as shown in Fig. 1.

The arm N is extended beyond the attachment of the link M, to form a lever or handle for operating the levers L to move the cylinders outward.

P is the carrier-plate, arranged in a vertical position, with its upper end just below the level of the under side of the table G and between the ties or guide-bars E and F, and set

at its lower end in the bar Q, which has a bearing at each end upon the vertical guide-rod R, upon which it is free to be moved up and down by any suitable means for imparting a reciprocating motion thereto and to the carrier-plate P.

To each end of the bar Q is attached one end of a cord or chain, S, which, after passing over the guide-pulley T, has its other end secured to the drum or pulley U, mounted upon the shaft V, adapted to be revolved by means of the crank W, or in any other well-known manner, to wind said cords or chains upon said drums, and thus move the carrier-plate upward between the cylinders H H<sup>1</sup>, to present the surface of the hide or skin doubled over the upper edge of the carrier-plate P to the action of the knives or scrapers *g g'* upon said cylinders.

The cylinders H H<sup>1</sup> are made up of several short sections, placed end to end upon a shaft to all outward appearance substantially the same as described in my aforesaid Letters Patent; but in the present case each section is made up of an inner cylinder or sleeve, *h*, made of metal, and secured firmly upon the shaft H<sup>2</sup> in such a manner that it can neither move endwise nor revolve thereon, an outer cylinder or sleeve, *h'*, made of metal, and provided with the blades *g* arranged obliquely upon its periphery, and an intermediate cylinder or sleeve, *i*, of rubber, interposed between the two metal sleeves, said rubber being so compressed in uniting the several parts that the outer sleeve of each section will be held from rotating about the inner sleeve by the friction of the rubber, while at the same time the rubber shall retain sufficient elasticity to allow of said outer sleeve yielding radially to accommodate itself to the irregularities in the surface of the hide or skin being worked.

In the under side of the table G is set the staple or pin *l*, in such a position relative to the slot *b* that when said table is moved under the cylinders H H<sup>1</sup> from the front toward the rear of the machine said staple or pin *l* will come in contact with the T or guide bar E just when the slot *b* in said table is directly over the carrier-plate P, as shown in Fig. 3.

The operation of my machine is as follows: The table G is first moved into the position indicated by dotted lines in Fig. 1, when the hide or skin to be worked is spread evenly thereon with the middle of its length over the slot *b*, when the table G is moved endwise in the direction indicated by the arrow *m*, by the operator or otherwise, till the stop *l* strikes the bar E and arrests the motion, when the carrier-plate P is made to move upward through the slot *b* of the table G, lifting the hide from said table by its middle, and carrying it up-

ward between the cylinders H H<sup>1</sup>, which are made to revolve toward each other, as indicated by the arrows *n o*, and at the same time are pressed against said hide by the weights K K, each of which acts independently of the others, so that if the hide should be thicker at one edge than at the other the cylinders will adjust themselves to the general surface of the skin, any little, short, or sudden variations in the thickness of the skin being compensated for by the independent yielding of the several sections or any one of them.

When the hide has passed up between the cylinders it may be removed from the plate P, and the cylinders H H<sup>1</sup> may be thrown apart by the operator pressing downward upon the end of the lever N while the carrier-plate P is returned to the starting-point.

I claim as new and desire to secure by Letters Patent of the United States—

1. In a machine for working out or operating upon hides or skins, a cylinder provided upon its outer periphery with one or more knives or scraping-blades, and having interposed between it and its shaft a cylinder of rubber, substantially as and for the purposes described.

2. A knife or scraping cylinder made up of an inner metallic tube or bushing, a cylinder of rubber surrounding said inner tube, and an outer tube or sleeve surrounding said rubber cylinder and provided with one or more knives or scraping-blades upon its outer periphery, all arranged and adapted to operate substantially as and for the purposes described.

3. In combination with a knife or scraping cylinder, the boxes *c c* or *c' c'*, screw-pivots *d d* or *d' d'*, and the slides I I or I' I', all arranged and adapted to operate substantially as described.

4. The combination of the cylinders H and H<sup>1</sup>, pivoted boxes *c c* and *c' c'*, slides I I and I' I', levers J J and J' J', weights K, levers L L, links M, levers N and N', and rocker-shaft O, all arranged and adapted to operate substantially as and for the purposes described.

5. The combination, in a machine for unhairing, scouring, or currying hides or skins, of the table G, provided with the slot *b* and adapted to be moved endwise in a horizontal direction, the carrier-plate P, adapted to be moved upward through the slot *b* of said table, and two knife or scraping cylinders arranged parallel, or nearly so, to each other, and with their axes in the same horizontal plane, substantially as described.

Executed at Boston, Massachusetts, this 28th day of January, A. D. 1878.

JOSEPH A. TALPEY.

Witnesses:

DORA H. PHILLIPS,  
N. C. LOMBARD.