

C. H. VIERECK.
Lanterns.

No. 207,088.

Patented Aug. 13, 1878.

Fig. 1.

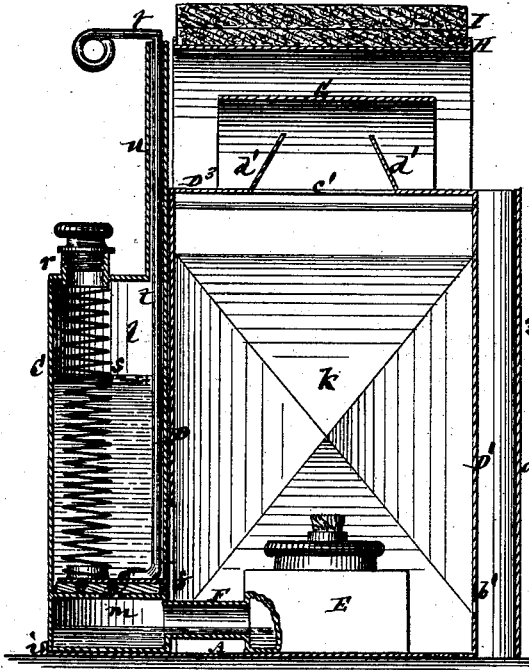

Fig. 2.

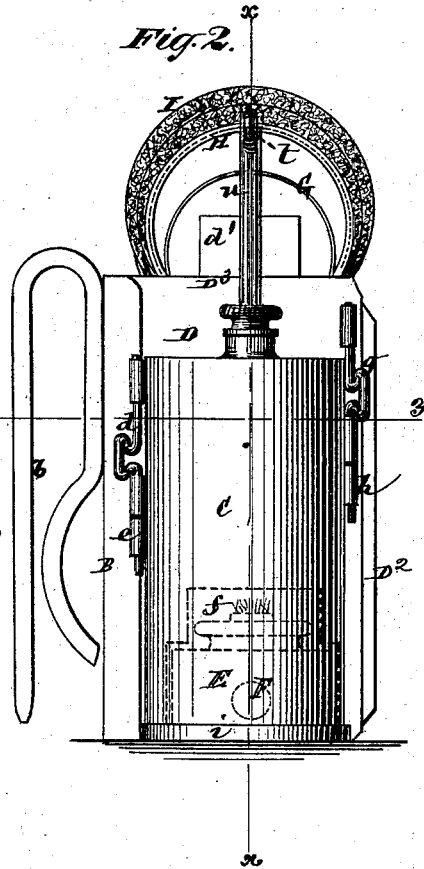
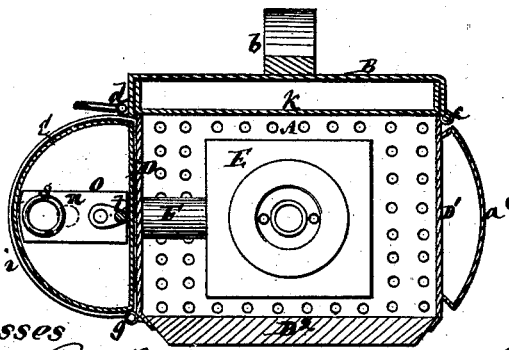

Fig. 3.



Witnesses
John Becker
Fred. Mayne

Inventor
Carl Heinrich Viereck
by his Attorneys
Brown & Allen

UNITED STATES PATENT OFFICE.

CARL H. VIERECK, OF SCHLESWIG, PRUSSIA.

IMPROVEMENT IN LANTERNS.

Specification forming part of Letters Patent No. 207,088, dated August 13, 1878; application filed June 19, 1878.

To all whom it may concern:

Be it known that I, CARL HEINERICH VIERECK, of Schleswig, in the Kingdom of Prussia, have invented certain new and useful Improvements in Lanterns, of which the following is a description, reference being had to the accompanying drawing, forming part of this specification.

This invention is more particularly intended to be applied to lanterns for use by railroad officials, mail-carriers, and others on railroads, in connection with fire-engines, and on board ships, but is not restricted to any particular service or use.

The invention consists in certain novel constructions of parts, whereby a lantern of small dimensions is made capable of burning for a lengthened period without refilling, and has an enlarged reflecting-surface to increase the brilliancy of the light, the reservoir for supplying the wick-chamber being on the exterior of the lantern-case; also, whereby the tendency of the lantern to become heated is reduced, likewise, the extinction of the light by drafts is avoided, and all spilling or overflow of the oil is prevented.

In the accompanying drawing, Figure 1 represents a vertical section of a lantern in a plane parallel with the glass front thereof, as indicated by the line *xx* in Fig. 2, which is a view of the lantern from its reservoir side; and Fig. 3 is a horizontal section of the same on the line *yy*.

The general contour of the lantern-case is preferably square or parallelogrammic. It is made with a perforated bottom, *A*, through which the air is admitted to keep up combustion. *B* is the opening and closing back or door of the lantern, provided with a hook, *b*, for the suspension of the lantern on a belt applied to the person or elsewhere. Said door is made hollow, or with inner and outer walls, having an air-space in between them to prevent the exterior of the back of the lantern becoming unduly or uncomfortably heated. Such door is united to one side of the lantern-case by one or more hinges, *c*, and may be secured, when closed, by a sliding fastening pin or bolt, *d*, made capable of being entered in and out of an eye or staple, *e*, on the front edge of the door, and carried by an oil-reservoir, *C*, which

is arranged externally down one side, *D*, of the lantern-case. This side *D* has an opening, *f*, through its lower portion, for the introduction through it and withdrawal, when required, of a wick-box, *E*, and supply-tube *F*, connecting said wick-box with the outside reservoir, *C*. This reservoir *C* is preferably of a semi-circular form externally, and is detachably secured to the outside of the lantern-case by the fastening pin or bolt *d*, hereinbefore referred to, and by an additional locking-pin, *g*, arranged to engage with an eye or staple, *h*, on the front side of the reservoir; or any other fastenings may be used. The bottom *A* of the case is extended to form a shelf or support, *i*, having turned-up edges for the outside reservoir *C* to rest upon. The opening *f* through the side *D* of the case is closed by the inner face of said reservoir when the latter is in place.

By the arrangement of the oil-reservoir *C* on the exterior of the case not only may a reservoir of enlarged capacity be used free from excessive heating of the case by the increased space gained within the latter, and this without adding materially to the bulk of the lantern, but said reservoir in nowise interferes with the reflection of the light, as provided for by the polished inner surface, *k*, of the back.

The oil-reservoir *C* is or may be constructed of an upper main chamber, *l*, and a lower smaller chamber, *m*, in communication with the upper chamber by an aperture, *n*, which is closed by a valve, *o*. The lower chamber, *m*, is connected by the tube *F* with the wick-box *E*, which latter is provided with the usual or any suitable wick-tube and cap. The upper chamber, *l*, has a filling-nozzle, *r*, closed by a screw plug or cap, and is also provided internally with a spring, *s*, which serves to keep the valve *o* closed. This valve is raised when it is required to supply the lower chamber, *m*, and through it the wick-box *E*, with oil, by lifting on a rod, *t*, arranged to extend through an air-tube, *u*. In this way or by these means the supply of oil to the wick may be graduated, free from any superincumbent pressure or head, and all risk of spilling oil is avoided.

The side *D*¹ of the lantern-case, which is arranged opposite to the side carrying the reservoir, has a convex-shaped plate, *a*¹, forming an upright through-flue on its exterior, which

serves to cover or protect a ventilating-aperture, *b'*, in said side from objectionable draft.

*D*² is the glazed front of the lantern, which is preferably made of thick plate-glass. The tube *D*³ of the lantern has an aperture, *c'*, in it, for escape of the products of combustion. This aperture is formed by flaps *d' d'*, produced by cut turned-up portions of the top *D*³, arranged to incline toward each other in an upward direction. Above and inclosing these flaps is a hood, *G*, open at both ends, and arranged so that the flaps *d' d'* partially intersect it transversely; and outside of said hood, running in the same direction as the latter, is another open-ended hood, *H*, leaving an air-channel between it and the hood *G*. This outer hood has one or more thicknesses of felt, *I*, or other poor conductor of heat, applied to its outer surface. Such construction of the top of the lantern prevents any overheating of the latter, and prevents the fingers of the person handling it from being burned. The flaps or wings *d' d'* also protect the flame from downward current.

I claim—

1. The combination, with the lantern-case, of a detachable outside oil-reservoir, with its attached wick box and tube, and supports and fastenings for maintaining its connection with the case, essentially as described.

2. The combination, with the outside reservoir, *C*, composed of an upper main chamber, *l*, a lower chamber, *m*, the valve *o*, controlling communication from the upper to the lower chamber, the spring *s*, for closing said valve, the rod *t*, extending through the tube *u*, for opening the said valve, the wick-box *E*, and duct or tube connecting the wick-box with the lower chamber, all constructed and arranged substantially as and for the purpose specified.

3. In combination with a lantern having a glazed front and reflector in rear of the light, the plate *a'*, secured to one side of said lantern, forming an upright through-flue, communicating with the interior of the lantern through an aperture, *b'*, as and for the purpose specified.

4. The combination of the outer open-ended hood, *H*, having a covering, *I*, of non-conducting material, applied to its outer surface, in combination with the inner open-ended hood, *G*, over the aperture *c'* in the top of the case, essentially as described.

C. H. VIERECK.

Witnesses:

W. C. SCHULTZ,
G. Y. KOCH.