

D. C. HILL.
Butter-Package.

No. 207,417.

Patented Aug. 27, 1878.

Fig 1

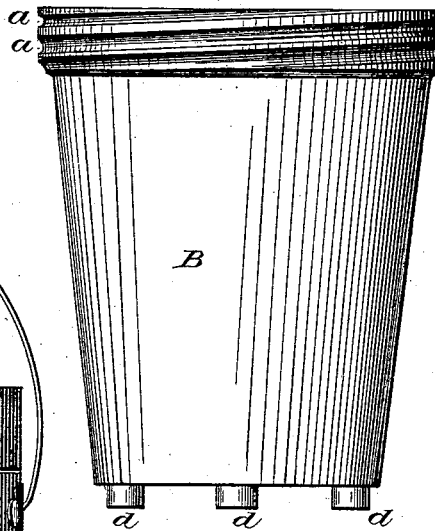
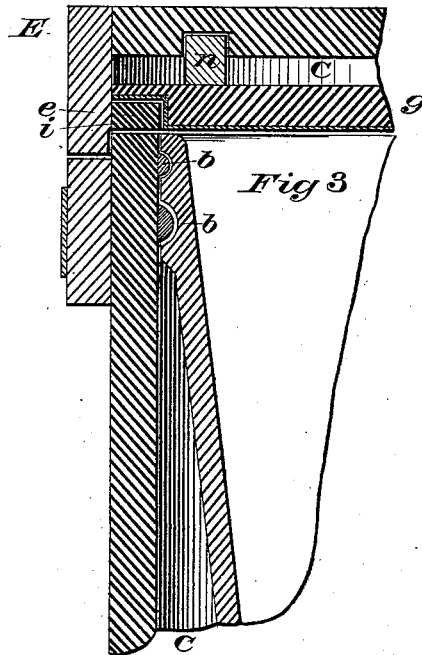
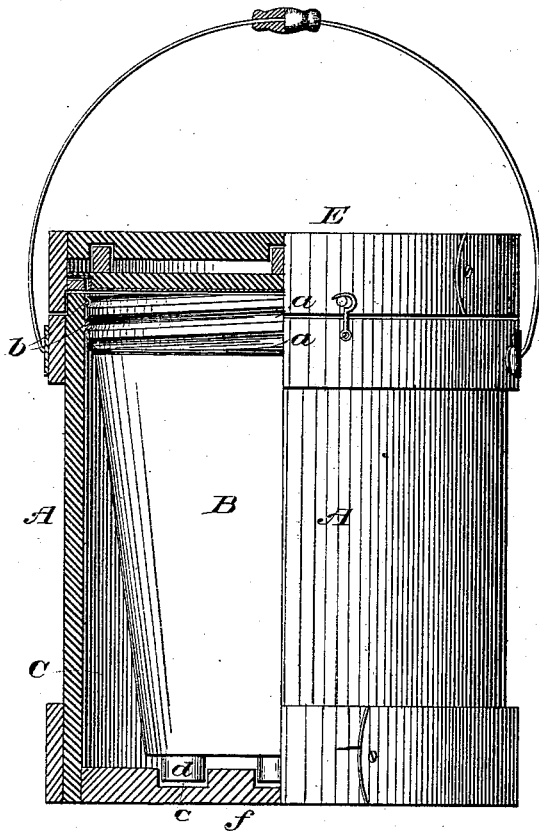

Fig 2



Witnesses:

Frank A. Cole
L. D. Campbell

Inventor

Daniel C Hill,

UNITED STATES PATENT OFFICE.

DANIEL C. HILL, OF RED WING, MINNESOTA.

IMPROVEMENT IN BUTTER-PACKAGES.

Specification forming part of Letters Patent No. **207,417**, dated August 27, 1878; application filed June 19, 1878.

To all whom it may concern:

Be it known that I, DANIEL C. HILL, of Red Wing, in Goodhue county and State of Minnesota, have invented a new and useful Improvement in Butter-Packages; and I do declare that the following is a true and accurate description thereof, reference being had to the accompanying drawings and letters of reference marked thereon, and being part of this specification, in which—

Figure 1 represents the inner jar or receptacle; and Fig. 2 shows a side view of the package, with the outside case cut away to show the inside jar and air-space and projections at the bottom of the jar. Fig. 3 is an enlarged section of cover and rim of jar, showing the manner of attaching the case to the jar by the means of the spiral groove and bead.

Similar letters of reference indicate corresponding parts in the several figures.

The object of this invention is to furnish a safe package for the transportation of butter, lard, and similar articles in metal, glass, or pottery-ware vessels, and to prevent the same from getting jammed or broken in transit or handling, and at the same time keep the contents cool not only while in transit, but also while in store or being kept for domestic use, and to so strongly attach the case to the jar that it cannot be broken apart, thus furnishing a strong and durable package for the purposes described.

In the drawings, A represents the outside wooden case, which can be made of staves or bent wood, or any other suitable materials, as may be most convenient; and B, the inner vessel, which can be made of metal, glass, or pottery-ware. C represents the air-space at the sides, bottom, and top. D represents the bail for the convenience of handling the package.

The inside vessel is fastened securely to the outside case by means of the spiral groove *a* in the rim of the jar B, in connection with the spiral bead *b* in the case A, (the groove *a* in B diminishes from the bottom up, so that when the case is turned onto the jar the union of the two becomes stronger and more complete as the case is brought to its place,) and in combination with the projections or legs at the bottom of the jar B, and corresponding cavities *c* in the bottom of the case A, so that when

the case A is screwed onto the jar B and the bottom *f* is fastened in its place, the projections *d* prevent the jar A from moving laterally, or from being turned out of the case B.

In the cover E, as shown in Fig. 3, there is an inside lid, *g*, made of the same material as the jar B, or otherwise, if more convenient, and placed so as to leave an air-space, C. This lid is held in its place by a rabbet, *i*, in its edge, and a corresponding rim, *e*, in the cover, and in combination with springs *n*, which may be of rubber or metal, to hold it firmly in its place, relieving the rigidity, and thus prevent breaking when it is made of fragile materials.

The outside is made of wood or other tenacious materials that have some elastic properties, together with the springs in the cover; and, when necessary, rubber springs can be put in the cavities in the bottom of the case, under the projections of the jar, thus giving the package enough elasticity to prevent the jamming or breaking of inner jar or receptacle under any ordinary or reasonable use in handling or transportation.

The case is so constructed that there is an inclosed air-space on all sides between the outer case and inner jar, thus serving to keep the contents cool under all ordinary circumstances, and at the same time furnish a strong, compact, and durable package for the purposes set forth.

Having thus fully described my invention, I claim—

1. The inside vessel, B, having in its rim the spiral groove *a*, slightly diminishing in size toward the top, and having the projections *d* at its bottom.

2. The outside case, A, having spiral bead *b*, slightly diminishing toward the top, and having the cavities C in the bottom.

3. The combination of the case A, having spiral bead *b*, and cavities C, with the interior vessel, B, having spiral groove *a* and projections *d*, and cover E, having rim *e*, inclosing the spring-mounted lid *g*, rabbeted at *i*, as and for the purposes set forth.

DANIEL C. HILL.

Witnesses:

FRANK A. COLE,
LUCIUS CAMPBELL.