

J. W. HODGES.
Gas-Generator.

No. 207,521.

Patented Aug. 27, 1878.

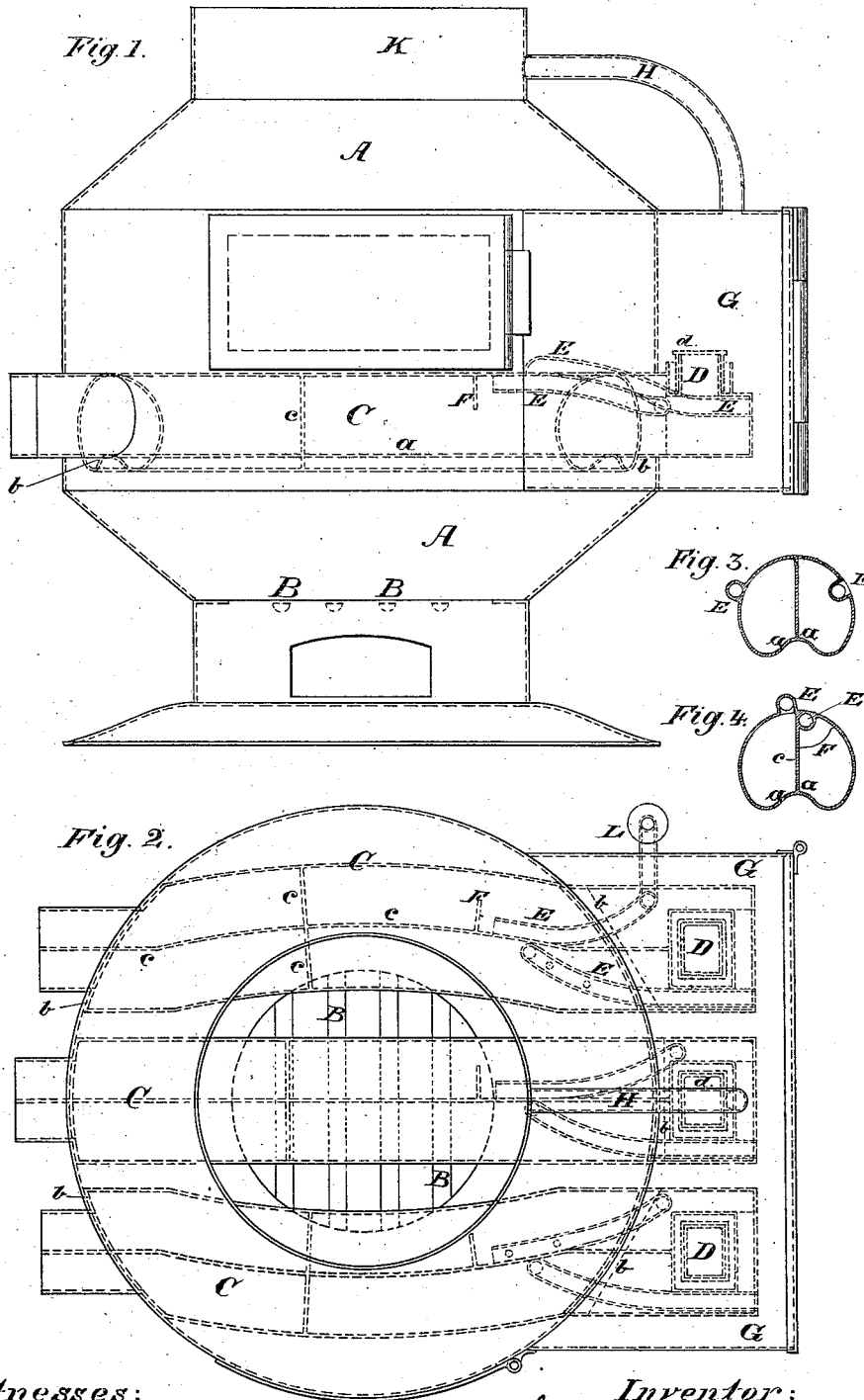

Witnesses:

Wm. Weffer
Bray Taylor

Inventor:

James W. Hodges
Per. P. V. Voorhees

Atty:

UNITED STATES PATENT OFFICE.

JAMES W. HODGES, OF FLUSHING, NEW YORK.

IMPROVEMENT IN GAS-GENERATORS.

Specification forming part of Letters Patent No. **207,521**, dated August 27, 1878; application filed February 23, 1878.

To all whom it may concern:

Be it known that I, JAMES W. HODGES, of Flushing, in the county of Queens and State of New York, have invented a new and useful Improvement in Illuminating or other Gas Generators, of which the following is a specification:

The invention relates more particularly to that class of generators which produce fixed illuminating-gas from liquid material, such as petroleum or other hydrocarbon oils; but any other gas can be generated, if desired, to the production of which the said generators may be suited.

For the most economic production of gas from liquid material, and in order to obtain gas of the best quality, it is necessary that the oil or other liquid should be projected in small drops or very minute quantities upon highly-heated surfaces. While to a certain extent this has been heretofore attempted and accomplished in certain gas-generators, yet practically the full benefits of such method have not been attained, owing to certain defects of construction, causing not unusually the production of inferior gas and much clogging of the pipes and parts of the generators with the solid residue of the oils employed. Such defects it is the object of this invention to obviate, and thus to secure a maximum of superior gas, economically produced, without requiring very nice care and attention for its production, but only ordinary care on the part of an attendant of ordinary intelligence.

The invention mainly consists of one or more retorts provided with safety escape seals or valves upon the end or ends thereof, in combination with an external chamber inclosing said ends.

The invention also consists in a certain combination of straight and curved retorts.

It also consists in certain details or combinations of internal construction of retort, as hereinafter fully described.

The invention is fully illustrated in the accompanying drawing, forming part of this specification, in which like letters of reference indicate like parts, and in which—

Figure 1 illustrates a side elevation of the apparatus or generator, partly in section. The remaining figures illustrate details hereinafter

fully described. Fig. 2 also illustrates the apparatus in plan.

The body A of the generator may be of any desired form or configuration, somewhat like an ordinary stove, and preferably of cast-iron of a maximum size, not too large for convenient moving by one or two men. The "stove," as it may be called, contains a grate and furnace, B, and a series of retorts or cells, C, arranged within the furnace above the grate, with a view of absorbing all the most intense heat of the furnace possible. Three of these retorts are shown in the drawing; but any desired number may be used, depending upon the size of the furnace. Within practical limits the greater the number of independent generating-cells of small magnitude and high temperature the more efficient will be the apparatus. It is desirable, therefore, that these retorts be no larger than will suffice for room enough to open either ends of them for cleaning them out with small scrapers or rods. Each retort has cast upon one end a seal-chamber, D, for liquids or molten metal, which does not differ in principle from an ordinary hydraulic seal; or any other suitable valve-chamber may be cast thereon. This end of the retort may be closed by a cover or bonnet, secured by bolts and luted with clay, or may have only a screw cap or plug. Through this end, therefore, the retort may be cleaned out, or through the seal-valve also, if desired. The opposite end of the retort, where the exit-pipe joins, may also have a cap or detachable joint for cleaning out the retort. Each retort has also cast upon or within its body, and forming part of its walls, one or more conduits, E, which discharge into the interior of the retort near a central point therein, and are continued through and within the walls of the retort, either to its extreme end or sidewise through the furnace-wall, if desired. In front of the inner orifice of the said conduit is cast a plate or barrier, F, which forms a scattering-plate for the oil entering the conduit E. The conduit E may also have one or more discharge-orifices along its length. The retorts need not necessarily be tubular, but may be square or cylindrical cells, having vertical axes normal to instead of parallel with the grate. The bottom of each retort or cell is cast in the form

of a convex floor, as seen at *a*, and transversely of the interior bottom or floor of the retort, if tubular, are cast ribs or barriers *b*, near the ends of the retort. A single retort may be also subdivided into cellular retorts of but one casting by partitions *c*, each sub-retort or cell being provided with its own induction and ejection pipe.

The body of the stove or generator is provided, either cast on or detachably connected thereto, with a seal-chamber, G. Into the said chamber the safety-seal or valved ends of the retorts are protruded through the walls of the furnace. This chamber may be provided with any suitable kind of door large enough for access of the hands to the seal-valves placed therein upon the ends of the retorts. A suitable conduit or pipe, H, connects the seal-chamber G with the smoke-pipe K of the generator. An inlet-supply pipe, L, is connected to the conduit E. As many of these pipes as are required are led from one common feed-pipe, and any suitable ordinary stop-cocks and feed-pipe funnels are provided for convenience in feeding the generator or any one or more of its cells.

The generator is thus operated: The furnace being at a good heat and the retort sufficiently hot, oil is allowed to flow into the inlet-pipes L; thence it passes through the hot conduits E, and is projected with the force due to its head against the scattering-plate F, whence it falls in fine spray or drops upon the intensely-heated arched bottom of the retort, where it is instantly converted into a rich permanent gas, and passes out of the rear end of the retort to the washer or gas-holder through any suitable exit pipe or pipes. The conduit-pipes E may be conveniently cast in the angles formed by the partitions *c*, which divide the retorts into cells, when retorts so divided are used. The arched or convex bottom, in combination with the spray-plate F, forms an important construction within the retort, although each of said features, *per se*, I do not herein claim.

Attendants are frequently tempted to force the generation of gas by feeding the oil too fast. The consequence is inferior gas, waste of oil, and increased clogging of the pipes and retorts, for the oil being poured upon the generating-surfaces in too large volume for proper vaporization, part of the oil is merely boiled instead of being permanently decomposed. The spray-plate F, therefore, first precipitates the oil in the form of minute drops or spray, and then the heated arched floor of the retort presents a more rapidly-diffusing surface for spreading the oil out into a thin sheet than it does a flat or concave floor. Again, should the oil be improperly allowed to flow too fast, unless the crown of the arch *a* be flooded, the excess of oil will settle in the bottom of the retort below the crown *a*, leaving the hot gas-generating surface of the said crown bare, dry, and intensely hot for the rapid generation of gas of the best quality, as the oil is first pre-

cipitated almost exclusively upon the crown *a*. The transverse ribs *b* are important as barriers to confine the oil to the central and hottest part of the retort, the ends, of course, being cooler from their greater remoteness from the center of the furnace. Suitable caps *d* are provided for the seals, if a water or other liquid or molten seal be used, a valve of any suitable yielding form being provided, if desired, instead of a liquid seal. These valves or seals are intended for safety-outlets for the gas in case of any stoppage of its flow by collections of residue in the pipes. With generators as heretofore constructed stoppage of the pipes is not an unusual occurrence, and where the seals have been constructed to rest in and discharge into the furnace, the loss of gas through this source is considerable, to say nothing of the loss of molten metal blown into the furnace by the pressure of the escaping gas. By the method of construction herein described, the seal-valves are directly under the eye and care of the attendant by simply opening the door of the chamber G, instead of the door of the furnace. Thus any escape of gas through the seals becomes instantly apparent. The seal-chamber G prevents the escape of the gas into the apartment in which the generator may be situated, and the conduit or pipe K leads any gas that may escape safely and directly into the chimney of the generator. Another important office of the chamber G is the preservation of an equable and high temperature surrounding the safety-valves *d*, if the said valves or caps are inserted in molten lead, for then the contact of a cold draft of air must be excluded in order to insure complete fluidity of metal.

It is obvious from the construction of the retorts and their connections that ample provision has been made to clean them out, as well as their connecting-pipes, when a removal of oil-residue becomes necessary; but by virtue of the conjoint action of the spray-plate and convex bottom of the retort both the liability and frequency of the clogging of the pipes and retorts are greatly diminished, for such construction permits of a larger bore of feed-pipe than can safely be used without such devices. The convex bottom and transverse ribs also increase the strength and durability of the retorts, as do also the partitions cast therein. Where said partitions are used, the cells created thereby may each be provided with an independent seal or escape-valve discharging into one common seal-chamber.

It may be desirable in some situations to connect the safety escape-valves by an arm or wire with some simple form of alarm apparatus or gong, and also with a feed-cock, so that, if any serious obstruction should occur in the retorts or pipes, the alarm will be sounded and the feed shut off by the lifting of an escape-valve. A suitably-balanced damper, attached, by a line or otherwise, to the feed-cock handle, might at the same time be closed, and thus check the draft of the furnace; but

the details of such arrangements I reserve for applications for other Letters Patent.

Having thus fully described this gas-generator and its method of operation as of my invention, I claim—

1. An apparatus for the generation of illuminating or other gas, consisting of an external case or shell, as described, inclosing therein a furnace, in combination with one or more laterally-curved and one or more straight retorts, the said retorts being set with either or both ends thereof outside of said furnace, all combined and operating substantially as and for the purpose set forth.

2. In a gas-generating apparatus, a cellular retort for the generation of gas from liquid material, consisting of a single casting divided interiorly into a series of non-communicating cells, each cell being both an oil-receiver and a gas-generator, and operating substantially as and for the purpose set forth.

3. In a gas-generating apparatus, a retort for the generation of gas from liquid material, having a bottom of arched or convex interior form of section, and provided with a scattering-plate in the interior of the retort, whereby the liquid is first sprayed and then spread into a thin sheet, substantially as and for the purpose set forth.

4. In a gas-generating apparatus, a retort for the generation of gas from liquid material, provided with internal transverse ribs or barriers at or near its lines for its furnace-settings,

for the purpose of confining the liquid to the mid-section of the retort, substantially as and for the purpose set forth.

5. In a gas-generating apparatus, a retort for the generation of gas from liquid material, having a bottom of arched or convex interior form of section, and provided with internal transverse ribs or barriers, as described, whereby the entering liquid is both spread over and concentrated upon the most efficient decomposing or vaporizing surface of the retort, substantially as set forth.

6. In a gas-generating apparatus, secured to the walls thereof, an external chamber, in combination with one or more retorts having each a safety escape seal or valve opening into said chamber, whereby all gas discharged through said valve or valves is delivered into said chamber, substantially as and for the purpose set forth.

7. In a gas-generating apparatus, secured to the walls thereof, an external chamber provided with a conduit connecting said chamber with the smoke-pipe of the apparatus, in combination with one or more retorts, having each an end projected into said chamber, and provided with a safety escape seal or valve, substantially as and for the purpose set forth.

JAMES W. HODGES.

Witnesses:

P. R. VORHEES,
GEORGE DODGE.