

T. F. KING.
Coal and Ash Sifter.

No. 207,529.

Patented Aug. 27, 1878.

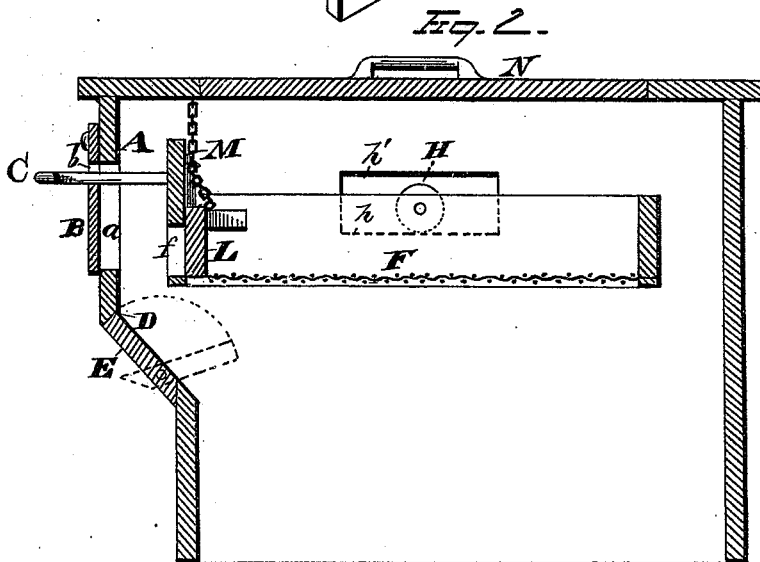
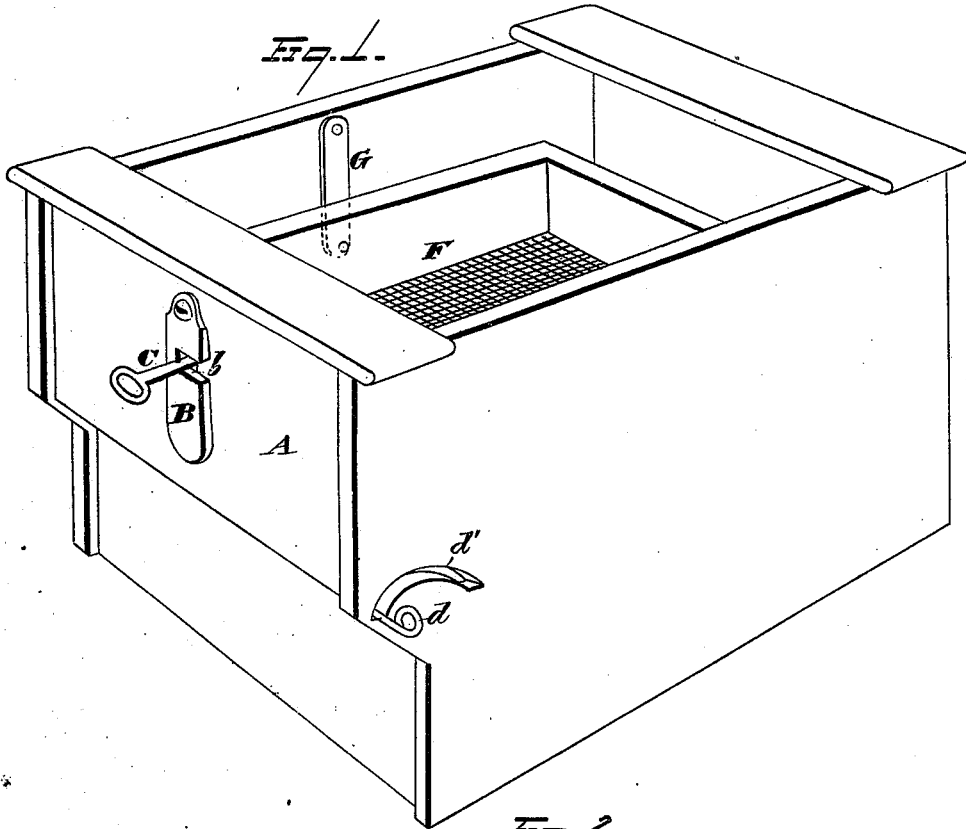

WITNESSES

Ed. S. Nottingham
A. W. Bright

INVENTOR

Theodore F. King.
By Degett & Degett
ATTORNEYS

T. F. KING.
Coal and Ash Sifter.

No. 207,529.

Patented Aug. 27, 1878

Fig. 3.

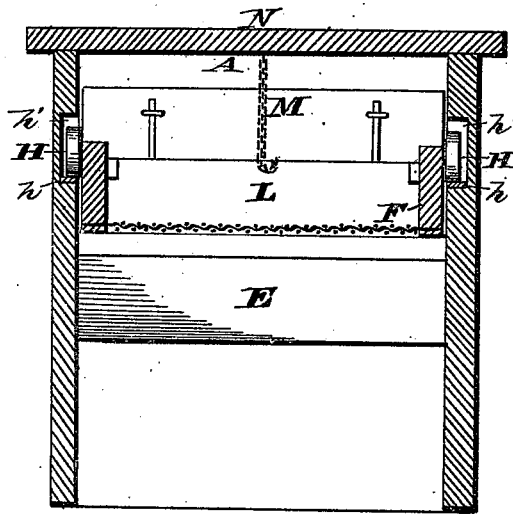

WITNESSES
Ed. J. Nottingham
A. M. Bright

INVENTOR
Theodore F. King
By *Dequette & Dequette*
ATTORNEYS

UNITED STATES PATENT OFFICE.

THEODORE F. KING, OF GENEVA, NEW YORK.

IMPROVEMENT IN COAL AND ASH SIFTERS.

Specification forming part of Letters Patent No. 207,529, dated August 27, 1878; application filed February 7, 1878.

To all whom it may concern:

Be it known that I, THEODORE F. KING, of Geneva, in the county of Ontario and State of New York, have invented certain new and useful Improvements in Coal and Ash Sifters; and I do hereby declare the following to be a full, clear, and exact description of the invention, such as will enable others skilled in the art to which it pertains to make and use it, reference being had to the accompanying drawings, which form part of this specification.

My invention relates to improvements in ash and coal sifters; and consists in a construction as follows:

The sifting-box is made with a forward projection of one of its end portions in the upper body thereof. Below this projection a discharge-opening for the sifted coal is formed, and is provided with an axially-tilting door, which latter is operated by a handle which works in a curved slot in the side of the sifting-box. The sieve is formed with a vertically-sliding gate in its discharge end, which works in guides secured thereto, while it is also connected to the upper portion of the sifting-box by suitable means, so that as the sieve is tilted down to discharge its sifted coal the gate will be automatically opened, and the coal will pass out therefrom and through the open end door of the sifting-box. The sieve may be supported either upon friction-rollers or upon hangers, and is adapted to reciprocate horizontally in the process of sifting by a handle which works in a vertical slot made in the forward end projection of the box. A plate is formed to cover this slot during such process and to support the handle in horizontal position. When the sifter is to be emptied of coal this plate is turned to one side, and the handle falls in the vertical slot, so as to tip or dump the sieve.

Referring to the drawings, Figure 1 is a view in perspective with the cover of the sifting-box removed. Fig. 2 is a longitudinal section with the box-cover in place, and showing friction-rollers instead of hangers as the support of the sieve. Fig. 3 is an inner front-end elevation view.

The sifting-box is formed with one of its ends made with its upper portion projecting

forward, as shown at A, and which is provided with the vertical slot *a*, over which the sliding plate B is adapted to be moved, so as to cover the slot, or to leave it open or exposed. This plate is formed with the transverse notch or slot *b*, through which the sieve-handle C works in horizontal reciprocation, and it serves to support the handle and the connecting-sieve in horizontal line during the process of sifting. The diagonally-inclined lower portion of the end projection A is provided with the discharge-opening D, which latter is adapted to be closed or opened by the axially-tilting door E. A handle, *d*, projects through the curved slot *d'* in the side of the box, and provides means for readily operating the door.

The sieve F may be of any suitable size and proportion of parts corresponding to the sifting-box, and may be secured thereto in different ways. In Fig. 1 of the drawings I show the same supported by hangers G, pivoted at lower and upper extremities, respectively, to the sides of the sieve and sieve-box, while in Figs. 2 and 3 the anti-friction rollers H are journaled to the sides of the sieve, and are adapted to travel upon suitable tramways *h* formed in recesses *h'* in the side bodies of the sifting-box. The discharging end of the sieve is provided with the gate L, which may slide vertically in any suitable manner.

Though the guide mechanism shown is preferred by me, yet the same may be changed without affecting my invention. A connection, M, engages this gate with an upper portion of the sifting-box, and is adapted to raise the gate from in front of the discharge-opening *f* of the sieve. Preferably this connection is a chain, but any other suitable connecting means may be substituted therefor.

A cover, N, fits over the top opening of the sifting-box, and after the coal and ashes are deposited in the sieve this cover is put on in place, and, the door E being closed, the sieve is reciprocated by means of the handle C, which is supported in horizontal line by the notched plate B. The ashes and fine matter pass through the meshes of the sieve and out through the open bottom of the box. When the same is properly sifted, the axially-tilting door is opened in the front end of the sifter, the plate which supports the sieve-handle in

horizontal line is moved to one side, and, by dropping the discharge end of the sieve, the vertically-sliding gate automatically operates to allow the coal to pass from out the sieve and the sifting-box.

Having fully described my invention, what I claim as new, and desire to secure by Letters Patent, is—

1. An ash and coal sifting box made with the forward end projection and the discharge-opening below the same, said opening being provided with the tilting door, which latter may be with or without the handle, which works in a curved slot in the side of the box, substantially as set forth.

2. The combination, with the sieve provided with hangers or rollers, of the sifter-box, whose forward end projection is made with a vertical slot, in which the sieve-handle works, and whose body below said projection is provided with the discharge-opening and door, substantially as set forth.

3. The combination, with the sifting-box formed with the forward projection in its upper end body and the discharge-opening in its lower portion, of the tilting sieve, whose discharge end is provided with a gate adapted to have vertical movement within a guideway, and which is connected to the sifting-box by suitable means, substantially as set forth.

4. In an ash and coal sifter, the combination of the sieve, whose handle works in a vertical slot formed in the forward end projection of the box, and the adjustable plate adapted to cover said slot and to support the sieve-handle in horizontal reciprocation, substantially as set forth.

In testimony that I claim the foregoing I have hereunto set my hand this 4th day of February, 1878.

THEODORE F. KING.

Witnesses:

CHARLES N. HEINNESS,
HENRY LUDLOW.