

C. L. SHOLES.  
Type-Writing Machine.

No. 207,559.

Patented Aug. 27, 1878

Fig. 1.

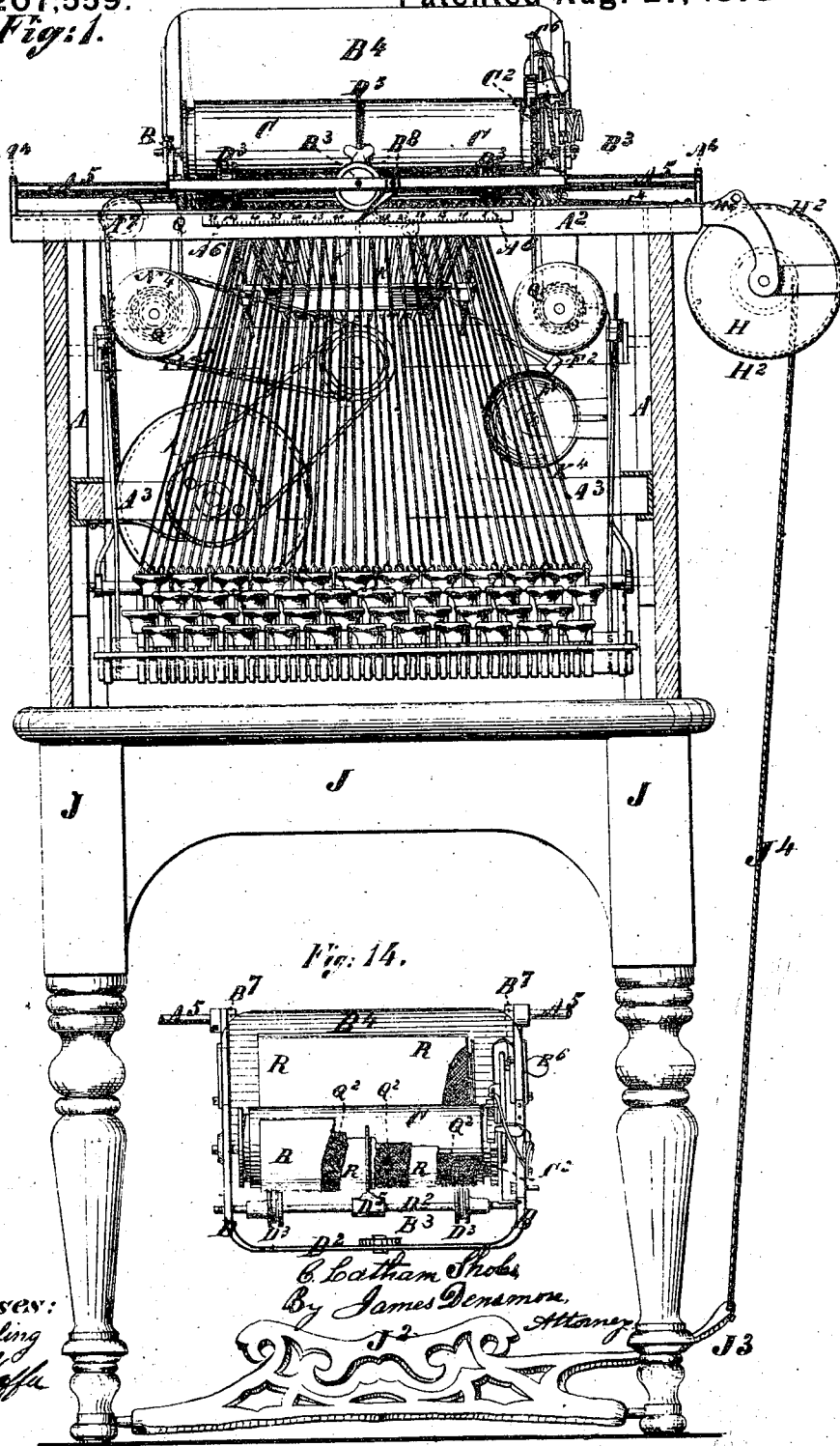

Witnesses:  
 H. C. Sicking  
 M. Schaff

C. Latham Sholes  
 By James Densmore, Attorney



# C. L. SHOLES. Type-Writing Machine.

No. 207,559.

Patented Aug. 27, 1878.

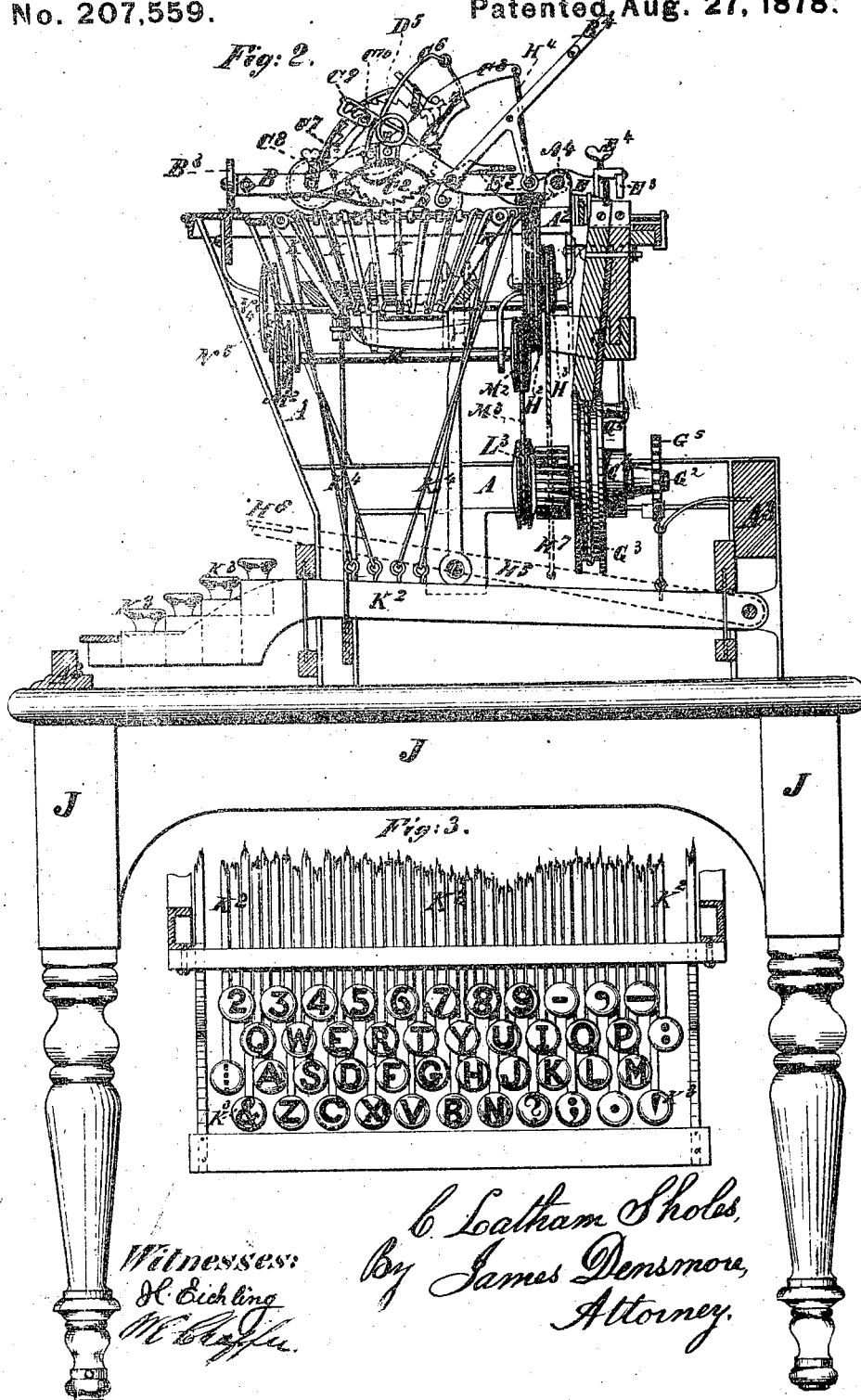

C. L. SHOLES.  
Type-Writing Machine.

No. 207,559.

Patented Aug 27, 1878.

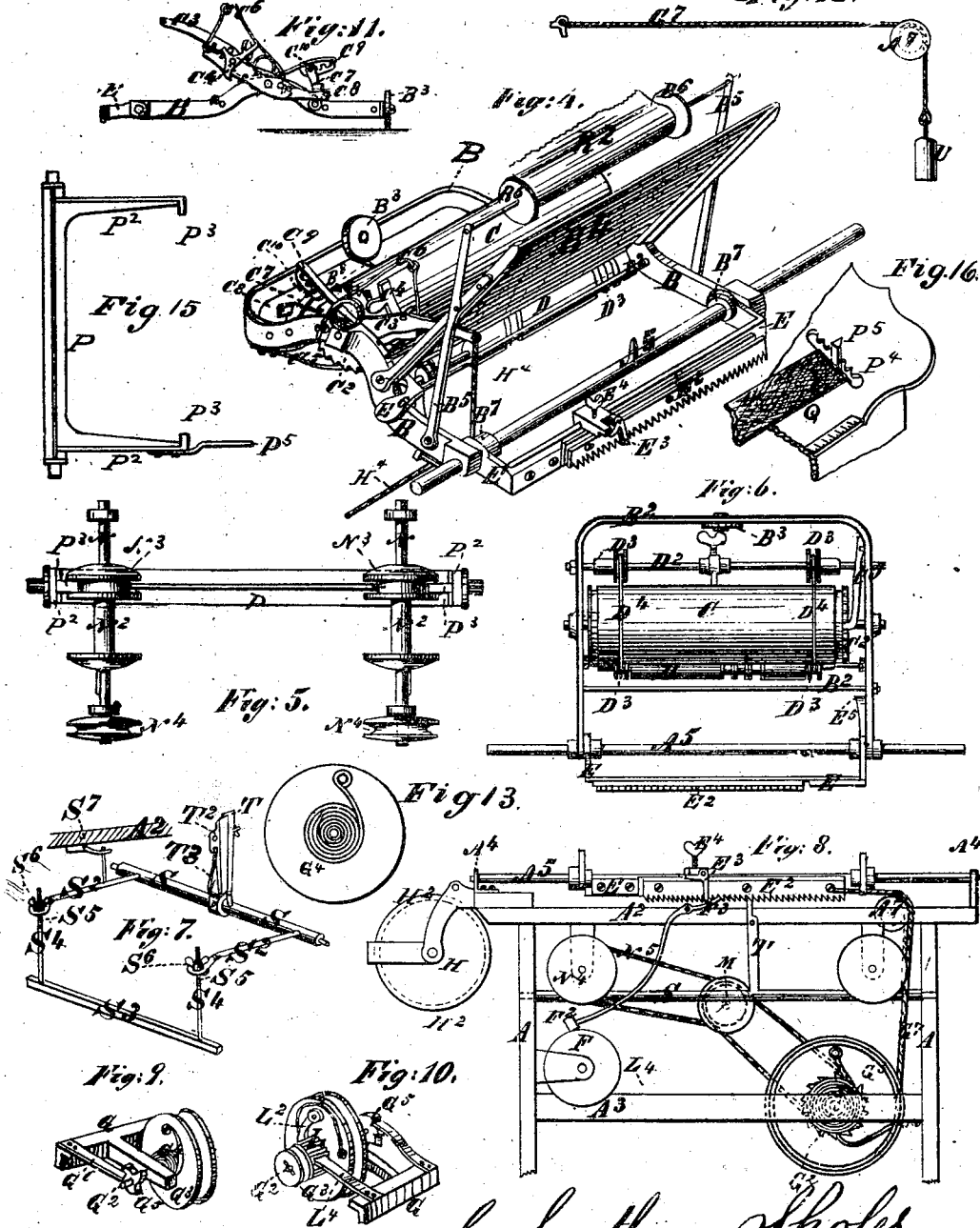

Witnesses:  
 L. Eichling  
 M. C. Chaffee

C. Latham Sholes,  
 By James Densmore,  
 Attorney.

# UNITED STATES PATENT OFFICE.

C. LATHAM SHOLES, OF MILWAUKEE, WISCONSIN, ASSIGNOR TO THE TYPE WRITER COMPANY, OF NEW YORK, N. Y.

## IMPROVEMENT IN TYPE-WRITING MACHINES.

Specification forming part of Letters Patent No. 207,559, dated August 27, 1878; application filed March 8, 1875.

*To all whom it may concern:*

Be it known that I, C. LATHAM SHOLES, of Milwaukee, Wisconsin, have invented Improvements in Type-Writing Machines, of which the following is a specification:

The invention relates to that class of type-writing machines in which the successive depression and release of a series of keys, one after another, vibrate and throw a series of types against an inking substance and the substance to be written on, and after each depression and release of any key, and while type and key are going back to place, move the latter substance a type-space distance, and thus make impressions or print or write one letter or character at a time; and the nature of the improvements is as follows: First, in combining a platen with a paper-carriage which has a hinge and guide rail, whereby the platen is adapted to move horizontally over the types of a type-writing machine, and to move up and off from over the same; second, in combining a platen which has axle-journals and bearings with a paper-carriage which has a hinge and guide rail, whereby the platen is adapted both to turn on and move along the line of its axis horizontally over the types of a type-writing machine, and to move up and off from over the same; third, in combining a ratchet-bar which has a hinge and guide-rail with the paper-carriage and letter-space ratchets of a type-writing machine; fourth, in combining an adjustable stop with the paper-carriage of a type-writing machine; fifth, in combining an adjustable trip with the paper-carriage and bell of a type-writing machine; sixth, in combining an adjustable trip-stop with the paper-carriage and bell of a type-writing machine; seventh, in combining a vibratory lever with the platen-driving ratchet and ratchet-wheel, paper-carriage, and ratchet-bar of a type-writing machine; eighth, in combining an adjustable guide-rack with the ratchet-lever and platen-driving ratchet and ratchet-wheel of a type-writing machine; ninth, in combining springy or elastic carrying-bands with a yielding pressure-roller and the band-pulleys and revolving platen of a type-writing machine; tenth, in combining a hand-lever with the connecting-cords, cone pulley, and paper-car-

riage of a type-writing machine; eleventh, in combining a driving-wheel and transmitting mechanism with the spring-wheel of a type-writing machine; twelfth, in combining a driving-ratchet, attached to the spring-wheel, and a holding-ratchet, attached to the frame, with a ratchet-wheel, transmitting mechanism, and the inking-ribbon of a type-writing machine; thirteenth, in combining an adjustable guide or regulator with the ribbon-spools of a type-writing machine; and, fourteenth, in combining a rocking frame and guide-rack with the ribbon-spools of a type-writing machine.

The accompanying drawing and following description fully illustrate the invention.

The figures of the drawing represent views as follows: Figures 1 and 2, a front and side view of the invention; Fig. 3, a view of the key board; Fig. 4, a view of the paper-carriage; Fig. 5, a view of the ribbon-spools and spool-guide; Fig. 6, another view of the paper-carriage; Fig. 7, a view of the letter-space ratchet rocking-frame; Fig. 8, a view of the cone-pulley, bell, spring-wheel, and ribbon-spools; Figs. 9 and 10, a view of each side of the spring-wheel; Fig. 11, a view of the line-space ratchet and guide; Fig. 12, a view of a weight, cord, and pulley; Fig. 13, a view of the spring-wheel spring; Fig. 14, a view of the paper-carriage and platen, with alternate series of writing and inking papers; and Figs. 15 and 16, views of the ribbon-spool guide or regulator.

The description is as follows: A represents the side plates of the main frame of a type-writing machine; A<sup>1</sup>, a top plate on the side plates A; A<sup>2</sup>, two or more cross-bars, attached to the side plates A; A<sup>3</sup>, a lug, extended up from each lateral edge of the top plate A<sup>1</sup>; A<sup>4</sup>, a rail attached to the lugs A<sup>3</sup>, across over the top plate A<sup>1</sup>; A<sup>5</sup>, a scale, on the front edge of the top-plate A<sup>1</sup>; A<sup>6</sup>, a bearing-wheel in a slot through the top-plate A<sup>1</sup>, near the end of the rail A<sup>4</sup>; B, the paper-carriage side bars, adapted both to hinge on and slide along the rail A<sup>4</sup>; B<sup>1</sup>, the carriage cross-bars, attached to the side bars B; B<sup>2</sup>, one or more traveling wheels, attached to the carriage-frame B B<sup>1</sup>; B<sup>3</sup>, a paper-table on the carriage B B<sup>1</sup> B<sup>2</sup>; B<sup>4</sup>, a standard on the carriage B B<sup>1</sup> B<sup>2</sup>; B<sup>5</sup>,

a reel in bearings on the standard B<sup>5</sup>; B<sup>6</sup>, a journal-lug on the hind end of each carriage side bar B; B<sup>7</sup>, an index on the front carriage cross-bar, B<sup>8</sup>, and extended so as to point to the marks and numbers on the scale A<sup>6</sup>; C, a cylindrical platen in bearings on the carriage B B<sup>7</sup> B<sup>8</sup>; C<sup>1</sup>, a ratchet-wheel on the end of the platen C; C<sup>2</sup>, a lever hinged on the platen-axle C, between the ratchet-wheel C<sup>1</sup> and the adjacent carriage side bar B, and extended forward and down near the front carriage cross-bar B<sup>7</sup>, and backward and up nearly over the hinge-rail A<sup>5</sup>; C<sup>3</sup>, a driving-ratchet, attached to the hinged lever C<sup>2</sup>, behind the platen-axle C, so as to work in the platen ratchet-wheel C<sup>1</sup>; C<sup>4</sup>, a holding-ratchet, attached to the carriage-frame B B<sup>7</sup>, so as to work in the platen ratchet-wheel C<sup>1</sup>; C<sup>5</sup>, a spring, attached to the carriage-frame B B<sup>7</sup> and to the hind end of the ratchet-lever C<sup>2</sup>; C<sup>6</sup>, a guide-rack, pivoted to the carriage side bar B, forward of the platen C, next the ratchet-lever C<sup>2</sup>; C<sup>7</sup>, a bent end or pin, attached to the fore end of the ratchet-lever C<sup>2</sup>, and extended so as to work in the guide-rack C<sup>6</sup>; C<sup>8</sup>, a spring-rack, attached to the carriage-frame B B<sup>7</sup>, and extended forward to the guide-rack C<sup>6</sup>; C<sup>9</sup>, a bent end or pin, attached to the upper end of the guide-rack C<sup>6</sup>, and extended so as to work in the spring-rack C<sup>8</sup>; D, a pressure-roller in slot-bearings on the carriage-frame B B<sup>7</sup>, parallel with and behind the platen C; D<sup>1</sup>, an axle, attached to the carriage side bars B, across, in front of, and parallel with the platen C; D<sup>2</sup>, a band-pulley, loose on each end of the pressure-roller axle D and front axle D<sup>1</sup>; D<sup>3</sup>, a carrying-band over each two corresponding band-pulleys D<sup>2</sup>; D<sup>4</sup>, a paper-guide on the front band-pulley axle, D<sup>1</sup>, between the carrying-bands D<sup>3</sup>, and extended up and curved back over the platen C; E, a vibratory frame, hinged on the journal-lugs B<sup>7</sup>, between the carriage side bars B; E<sup>1</sup>, a ratchet-bar, attached to the vibratory frame E, behind and parallel with the hinge-rail A<sup>5</sup>; E<sup>2</sup>, a trip-stop, attached to, so as to slide along on, the ratchet-bar E<sup>1</sup>; E<sup>3</sup>, a set-screw, attached to the trip-stop E<sup>2</sup>, so as to set and fasten it to the ratchet-bar E<sup>1</sup>; E<sup>4</sup>, an arm, attached to the ratchet-bar frame E, and extended forward, next the carriage side bar B; E<sup>5</sup>, a finger-piece, pivoted to the carriage side bar B, so as to vibrate and strike and rest on the ratchet-bar arm E<sup>4</sup>; F, a bell, attached to and within the main frame A A<sup>2</sup> A<sup>3</sup>, under the ratchet-bar E<sup>1</sup>; F<sup>1</sup>, a hammer pivoted to the top plate A<sup>2</sup>, so as to vibrate and strike the bell F; F<sup>2</sup>, a handle attached to the bell-hammer F<sup>1</sup>, and extended up through the top plate A<sup>2</sup>, so as to be struck and vibrated by the trip-stop E<sup>2</sup>; G, a frame attached to the side plate A, under the hinge-rail A<sup>5</sup>; G<sup>1</sup>, an axle in bearings on the frame G; G<sup>2</sup>, a wheel, loose on the axle G<sup>1</sup>; G<sup>3</sup>, a coiled spring, attached to the loose wheel G<sup>2</sup> and wheel-axle G<sup>1</sup>; G<sup>4</sup>, a ratchet-wheel, attached to the spring-wheel axle G<sup>1</sup>; G<sup>5</sup>, a hold-

ing-ratchet, attached to the spring-wheel frame G, so as to work in the ratchet-wheel G<sup>4</sup>; G<sup>6</sup>, a cord attached to the spring-wheel G<sup>4</sup> and carriage B B<sup>7</sup> B<sup>8</sup>, and passed over the bearing-wheel A<sup>7</sup>; H, a cone-pulley, attached to the main frame A A<sup>2</sup> A<sup>3</sup>; H<sup>1</sup>, the large sheave of cone-pulley H; H<sup>2</sup>, the small sheave of the cone-pulley H; H<sup>3</sup>, a cord attached to the cone-pulley large sheave H<sup>2</sup> and the hind end of the ratchet-lever C<sup>2</sup> on the carriage B B<sup>7</sup> B<sup>8</sup>; H<sup>4</sup>, a hand-lever, pivoted to the outer side at the hind end and extended to the front end of the side plate A, under the cone-pulley H; H<sup>5</sup>, a key on the fore end of the hand-lever H<sup>4</sup>; H<sup>6</sup>, a cord attached to the cone-pulley small sheave H<sup>2</sup> and hand-lever H<sup>4</sup>; J, a stand under the main frame A A<sup>2</sup> A<sup>3</sup>; J<sup>1</sup>, a treadle, pivoted at the bottom between the front legs of the stand J; J<sup>2</sup>, an arm attached to the treadle J<sup>1</sup>, and extended backward under the cone-pulley H; J<sup>3</sup>, a cord attached to the cone-pulley small sheave H<sup>2</sup> and treadle arm J<sup>1</sup>, in place of the hand-lever H<sup>4</sup>; K, a series of types, pivoted and set in an aperture in the top plate A<sup>2</sup>, so as to vibrate and all strike up against the same point at the bottom of the platen C; K<sup>1</sup>, a series of levers, side by side, pivoted at the hind end and extended through to the fore end, at the bottom of the main frame A A<sup>2</sup> A<sup>3</sup>; K<sup>2</sup>, a type-key on the fore end of each key-lever, K<sup>1</sup>; K<sup>3</sup>, a connecting-wire attached to the radially outer end of each type K and to each key-lever K<sup>2</sup>; L, a ratchet-wheel, loose on the spring-wheel axle G<sup>1</sup>, next the wheel G<sup>2</sup>, on the side opposite the coiled spring G<sup>3</sup>; L<sup>1</sup>, a driving-ratchet, pivoted to spring-wheel G<sup>1</sup> G<sup>2</sup>, so as to work in the loose ratchet-wheel L; L<sup>2</sup>, a driving wheel or pulley attached to the loose ratchet-wheel L; L<sup>3</sup>, a holding-ratchet, attached to the wheel-frame G, so as to work in the loose ratchet-wheel L; M, an axle in bearings, attached to and within the main-frame A A<sup>2</sup> A<sup>3</sup>, across under the types K, parallel with the key-levers K<sup>2</sup>; M<sup>1</sup>, a transmitting wheel or pulley, attached to each end of the long axle M; M<sup>2</sup>, a driving-cord over the driving-pulley L<sup>1</sup> and corresponding transmitting-pulley M<sup>1</sup>; N, an axle, similar to and parallel with the transmitting-pulley axle M, in bearings at each side of the types K, within the main frame A A<sup>2</sup> A<sup>3</sup>; N<sup>1</sup>, a spool, on so as both to turn with and slide along each side axle N; N<sup>2</sup>, a grooved pulley attached to each spool N<sup>1</sup>; N<sup>3</sup>, a transmitting wheel or pulley on the fore end of each spool-axle N; N<sup>4</sup>, a transmitting cord over the front long-axle transmitting-pulley M<sup>1</sup> and over one of the spool-axle transmitting-pulleys N<sup>2</sup>; P, a rocking bar, in bearings in the side plates A, across, over, and down next the key-levers K<sup>2</sup>, under the spools N<sup>1</sup>; P<sup>1</sup>, an arm attached to each end of the rocking bar P and extended up to the corresponding spool N<sup>2</sup>; P<sup>2</sup>, a finger attached to the upper end of each vertical rocking arm P<sup>1</sup>, and extended into the groove of the contiguous spool-pulley N<sup>2</sup>; P<sup>3</sup>, a ratchet-bar or rack, at-

tached to the edge of a slot through the top plate A<sup>2</sup> over one of the spools N<sup>2</sup>; I<sup>2</sup>, a spring-ratchet, attached to the upper end of one of the vertical rocking arms P<sup>2</sup>, and extended up through the slot in the top plate A<sup>2</sup>, so as to work in the rack P<sup>2</sup>; Q, an inking-ribbon attached to each spool N<sup>2</sup>, and extended up through the top plate A<sup>2</sup> and over the types K, under the platen C; R, a sheet of paper or other substance on the carriage B B<sup>2</sup> B<sup>3</sup>, under the platen C; R<sup>2</sup>, a roll of paper or other substance on the reel B<sup>2</sup>, in place of separate sheets set on the paper-table B<sup>2</sup>; S, a rocking bar, pivoted to the side plates A, across up near the top plate A<sup>2</sup>, under the ratchet-bar E<sup>2</sup>; S<sup>2</sup>, an arm attached to each end of the upper rocking bar S, and extended forward nearly to the front edge of the top plate A<sup>2</sup>; S<sup>3</sup>, a cross-bar under and up against the key-levers K<sup>2</sup>, forward of the connecting-wires K<sup>2</sup>; S<sup>4</sup>, a connecting-wire attached to each end of the under cross-bar S<sup>2</sup>, and extended up through the corresponding horizontal rocking-bar arm S<sup>2</sup>; S<sup>5</sup>, a screw-thread on the upper end of each rocking-bar arm connecting-wire S<sup>4</sup>; S<sup>6</sup>, a set-screw over each screw-thread S<sup>5</sup>; S<sup>7</sup>, a spring attached to the top plate A<sup>2</sup> and horizontal rocking-bar arm S<sup>2</sup>; T, a ratchet attached to the upper rocking bar S, and extended up through the top plate A<sup>2</sup>, so as to work in the ratchet-bar E<sup>2</sup>; T<sup>2</sup>, another ratchet, pivoted to the rocking-bar ratchet T, so as to vibrate in a plane parallel with the longitudinal line of the rocking bar S; T<sup>3</sup>, a spring attached to the upper rocking bar S, so as to press against the pivoted ratchet T<sup>2</sup>; and U, a weight, in place of the spring wheel G<sup>2</sup> G<sup>3</sup>, attached to the carriage-cord G<sup>2</sup>.

It is known that the combination of the working-power U with the depression and release of a type-key, K<sup>2</sup>, will throw the type K up against the inking-ribbon Q, paper R, and platen C, and impress a character on the paper, and also work the combined vibratory ratchets T T<sup>2</sup>, so as to hold the carriage B B<sup>2</sup> B<sup>3</sup> and paper and platen immovable while the type impresses the character, but move the whole a type-space distance after the impression, and while type and key are going back to place; but the operation and functions of these improvements are as follows:

First, the hinge-rail A<sup>2</sup>, in writing, guides the carriage B B<sup>2</sup> B<sup>3</sup>, and with it the paper R and platen C, horizontally in line over the types K, and allows it to be turned up and off from over to a vertical position at any time to bring the writing before the eyes, or to give access to clean or adjust the types, or to adjust or exchange the inking-ribbon Q.

Second, the hinges B<sup>2</sup> of the ratchet-bar frame E, after a line is written, allow the ratchet-bar E<sup>2</sup> to be moved up and off the combined ratchets T T<sup>2</sup>, while the paper-carriage B B<sup>2</sup> B<sup>3</sup> is drawn back to place.

Third, the trip stop E<sup>3</sup>, when near the end of the line, trips and vibrates the hammer F<sup>2</sup>

F<sup>2</sup>, which strikes and rings the bell F. The trip-stop also, at the end of the line, strikes the combined ratchets T T<sup>2</sup>, and stops the paper-carriage B B<sup>2</sup> B<sup>3</sup>, and, being adjustable, it can be set for any desired length of line.

Fourth, the depression of the ratchet-lever C<sup>2</sup> after a line is written, and while the paper-carriage B B<sup>2</sup> B<sup>3</sup> is drawn back to place, depresses the platen-driving ratchet, C<sup>2</sup>, which turns the platen ratchet-wheel C<sup>2</sup> and platen C and moves the paper R a line-space distance. At the same time the ratchet-lever depresses the ratchet-bar arm E<sup>2</sup> and lifts the ratchet-bar E<sup>2</sup> off the combined ratchets T T<sup>2</sup>, and the guide-rack C<sup>2</sup>, which is adjustable in the spring-rack C<sup>2</sup>, and which determines the distance of the vibration of the ratchet-lever, and thereby the distance which the ratchet-wheel and platen will turn and move the paper, thus guides or regulates the line space movement.

Fifth, the pressure-roller D and carrying-bands D<sup>2</sup> press the paper R against the platen C, and thereby aid the accuracy and surety with which the platen, in turning, moves the paper.

Sixth, the depression of the hand-lever H after a line is written unwinds the pulling-cord H<sup>2</sup> from the small sheave H<sup>2</sup>, and turns the cone pulley H and winds up the connecting-cord H<sup>2</sup> on the large sheave H<sup>2</sup>, and draws the paper carriage B B<sup>2</sup> B<sup>3</sup> back to place; but the connecting-cord, being attached to the hind end of the ratchet lever C<sup>2</sup> before the carriage can move the lever, will be pulled down, which will lift the ratchet-bar E<sup>2</sup> off the combined ratchets T T<sup>2</sup> and turn the platen C, and move the paper R a line space distance.

Seventh, the driving-ratchet L<sup>2</sup>, attached to the spring-wheel G<sup>2</sup> G<sup>3</sup>, turns the loose ratchet-wheel L and driving wheel pulley L<sup>2</sup>, and drives the transmitting mechanism L<sup>2</sup> M<sup>2</sup> M<sup>2</sup> N<sup>2</sup> N<sup>2</sup>, and moves the inking-ribbon Q when the spring-wheel turns forward in writing; and the holding-ratchet L<sup>2</sup> holds the loose ratchet-wheel and transmitting mechanism and inking ribbon immovable while the spring-wheel turns backward when the paper-carriage B B<sup>2</sup> B<sup>3</sup> is drawn back to place after a line is written.

Eighth, the rocking frame P<sup>2</sup> P<sup>2</sup> P<sup>2</sup> moves the inking-ribbon Q laterally, as desired, whenever the ink is exhausted in one line-course, and, being adjustable in the guide-rack P<sup>2</sup> by the spring-ratchet P<sup>2</sup>, it thereby regulates or guides the line-course of the inking-ribbon.

The combined vibratory ratchets T T<sup>2</sup>, attached to the upper rocking bar, S, are the letter-space ratchets. The ratchet-wheel C<sup>2</sup> on the end of the platen C is the platen ratchet-wheel. The ratchet C<sup>2</sup>, which drives the platen ratchet-wheel C<sup>2</sup>, is the platen-driving ratchet. The vibratory lever C<sup>2</sup>, which carries the platen-driving ratchet C<sup>2</sup>, is the ratchet-lever. The ratchet-lever C<sup>2</sup>, driving-ratchet C<sup>2</sup>, ratchet-wheel C<sup>2</sup>, platen C, pressure-roller D, and carrying-bands D<sup>2</sup> are the line-space mechanism, and the ratchet-wheel C<sup>2</sup> on the spring-wheel axle G<sup>2</sup> is the spring-wheel ratchet-wheel.

The combination of the type-bar of a type-writing machine which has a trunion or journal on each side with an annular circular disk which has a journal-bearing groove in its upper surface and a radial vertical slot through its inner periphery or edge forms no part of this invention, as it is the subject of another and separate application.

The combination of two ratchets, attached together side by side, pointed practically in the same direction, and pivoted so they may vibrate in the same plane in one direction, but one pivoted separately, so it may vibrate independently in a plane at a right angle to that of the joint vibration, so they may vibrate in parallel planes in the reverse direction, with only one series of ratchet-teeth and notches, and with the key-levers, vibratory frame, paper-carriage, and platen of a type-writing machine, the combination of a horizontal bar attached and pivoted so it may vibrate across in front of the key-levers with the vibratory frame and letter-space ratchets of a type-writing machine, and the combination of a cone-pulley which has a large and small sheave, with a pulling-cord attached to the small sheave and a connecting-cord attached to the large sheave and paper-carriage of a type-writing machine form no part of the invention; but the improvements which do constitute the invention, and therefore

What I claim are as follows:

1. The combination of a platen with a paper-carriage which has a hinge and guide-rail, whereby the platen is adapted to move horizontally over the types of a type-writing machine, and to move up and off from over the same, substantially as described.
2. The combination of a platen which has axle journals and bearings with a paper carriage which has a hinge and guide rail, whereby the platen is adapted both to turn on and move along the line of its axis horizontally over the types of a type writing machine, and to move up and off from over the same, substantially as described.
3. The combination of a ratchet-bar which has a hinge and guide rail with the paper-car-

riage and letter-space ratchets of a type-writing machine, substantially as described.

4. The combination of an adjustable stop with the paper-carriage of a type-writing machine, substantially as described.

5. The combination of an adjustable trip with the paper-carriage and bell of a type-writing machine, substantially as described.

6. The combination of an adjustable trip-stop with the bell and paper-carriage of a type-writing machine, substantially as described.

7. The combination of a vibratory lever with the platen-driving ratchet and ratchet-wheel, paper-carriage, and vibratory ratchet-bar of a type-writing machine, substantially as described.

8. The combination of a guide-rack with the ratchet-lever and platen-driving ratchet and ratchet-wheel of a type-writing machine, substantially as described.

9. The combination of springy or elastic carrying-bands with a yielding pressure-roller and the band-pulleys and revolving platen of a type-writing machine, substantially as described.

10. The combination of a hand-lever with the cone-pulley and paper-carriage of a type-writing machine, substantially as described.

11. The combination of a driving wheel and transmitting mechanism with the spring-wheel and inking-ribbon of a type-writing machine, substantially as described.

12. The combination of a driving-ratchet attached to the spring-wheel and a holding-ratchet attached to the frame with a ratchet-wheel, transmitting mechanism, and the inking ribbon of a type-writing machine, substantially as described.

13. The combination of an adjustable regulator with the ribbon-spools of a type-writing machine, substantially as described.

14. The combination of a rocking frame and guide-rack with the ribbon spools of a type-writing machine, substantially as described.

C. LATHAM SHOLES.

Witnesses:

JAMES DENSMORE,  
AMOS DENSMORE.