

A. H. BURLINGAME.
Rolling-Colter.

No. 207,589.

Patented Sept. 3, 1878.

Fig 1.

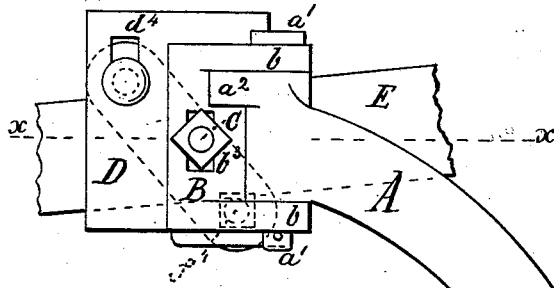

Fig 2.

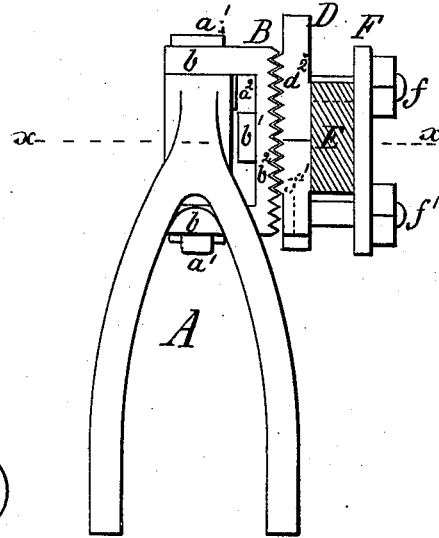

Fig 3.

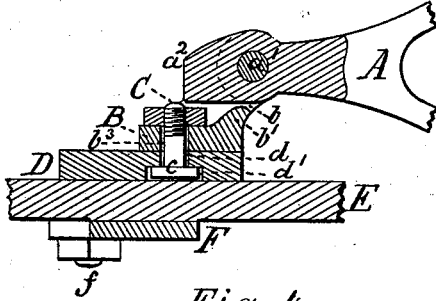

Fig 4.

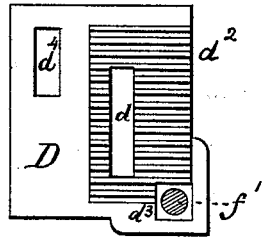
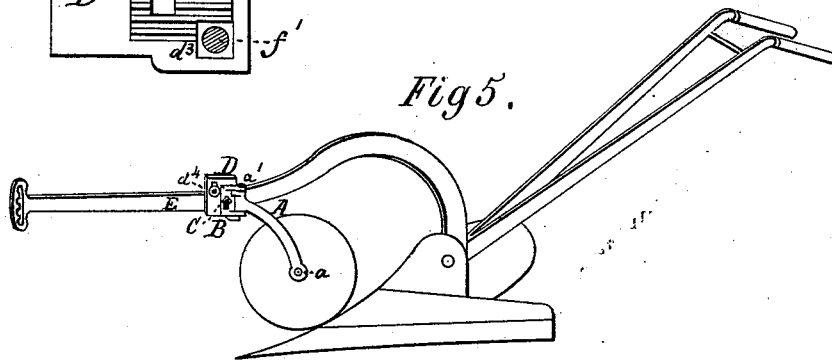

Fig 5.



Witnesses:

J. P. Th. Lang.
J. Russell Barr

Inventor:

Albert H. Burlingame
by
Mason, Remick & Co.

UNITED STATES PATENT OFFICE.

ALBERT H. BURLINGAME, OF SPARTA, ILLINOIS.

IMPROVEMENT IN ROLLING COLTERS.

Specification forming part of Letters Patent No. 207,589, dated September 3, 1878; application filed June 14, 1878.

To all whom it may concern:

Be it known that I, ALBERT H. BURLINGAME, of Sparta, in the county of Randolph and State of Illinois, have invented a new and useful Improvement in Rolling Colters, which improvement is fully set forth in the following specification and accompanying drawings, in which latter—

Figure 1 is a side elevation of my invention. Fig. 2 is a rear elevation of the same. Fig. 3 is a horizontal section in the lines $x x$ of Figs. 1 and 2. Fig. 4 is a detail view of one of the clamp-plates by means of which the colter is fastened to the plow-beam, and Fig. 5 is an illustration of the attachment of my improved colter to a plow.

The nature of my invention consists in certain constructions, combinations, and arrangements, hereinafter described and specifically claimed, whereby a revolving colter-frame can be very conveniently adjusted vertically and horizontally, and firmly secured after such adjustments.

In the drawings, A represents a forked colter-frame, provided with suitable holes, a , at its lower ends, into which the pivot of a rolling colter is inserted. The frame A is pivoted to and between two horizontal ears, b , of a plate, B, by means of a vertical pin, a^1 . The horizontal swinging motion of the frame A around the pin a^1 is limited on one side by a check, b^1 , formed on the plate B, and on the opposite side by a check, a^2 , formed on the upper part of the frame A, so that the frame will strike the check b^1 when swinging too far to the right, and the check a^2 will strike the plate B when the frame swings too far to the left. The back of the plate B is provided with transverse serrations b^2 , and with a longitudinal vertical slot, b^3 , through which latter a bolt, C, is passed, and which is also passed through a slot, d , in a plate, D. The head c of the bolt C is fitted into a vertical depression, d^1 , of the plate D, so as to be flush with its back.

The plate D is provided with serrations d^2 , similar to those b^2 of the plate B, into which serrations of plate B they fit or match whatever may be the adjustment up or down of the colter and its frame. The back of the plate D bears against the side of a plow-beam, E, to

which it is fastened by means of a diagonal clamp-plate, F, and two bolts, $f f'$. The head of the bolt f' is at d^3 let into the metal of the plate D, so that the surface of the said head will be flush with the surface of the plate D, and thus the plate B can move freely over it when its position is to be changed. The bolt f is passed through a slot, d^4 , in the plate D, in order that it may be raised or lowered to accommodate the colter to plow-beams of different widths.

When the colter-frame with colter attached is to be applied to a plow, the clamp-plate F is partly detached from the plate D by removing the bolt f . The plates D and F are then from below slipped over the end of the plow-beam E and the bolt f reinserted, and the plates D and F firmly clamped on the plow-beam E. The bolt C is then loosened and the plate B adjusted to the proper height, whereupon the bolt C is again tightened and the plates B and D firmly clamped together, and prevented by the serrations $b^2 d^2$ from slipping vertically upon each other, said clamp permitting the colter-frame to be adjusted in a horizontal direction upon the plow-beam, and in a vertical direction upon the plate D. Thus the general adjustments of the colter are greatly improved, for the reason that the vertical adjustment of the colter-frame which will suffice for a given depth of plowing can be secured independent of any horizontal adjustment, while the longitudinal horizontal adjustment, which depends upon the condition of the soil and must be altered as often as the soil changes, can be secured independent of the vertical adjustment.

The bolt f' , by its position below the plow-beam and nearest to the colter-frame, serves as a check against the turning of the plate D on the plow-beam, it being caused to bind against the beam by the upward force of the colter while in operation.

I am aware that a swinging and vertically-adjustable rolling-colter frame is not, broadly, new, and therefore I do not claim such as my invention; but,

Having thus described my invention, what I claim as new, and desire to secure by Letters Patent, is—

1. In a rotary colter, the combination of the plates B D, having horizontal serrations b^2 d^2 , and the bolt C, constructed substantially as shown and described.

2. The combination of the swinging frame A for a rotary colter, the serrated plates B D, clamp-plate F, and bolts C f f' , substantially as and for the purpose set forth.

3. The combination of the colter-frame A

and its check a^2 , the serrated plate B and its check b^1 , the serrated plate D, clamp-plate F, and bolts C f f' , all constructed and operating substantially as described.

ALBERT H. BURLINGAME.

Witnesses:

T. S. ELLIOTT,
W. K. HODSON.