

E. S. RITCHIE.
Lantern.

No. 207,625.

Patented Sept. 3, 1878.

Fig. 1.

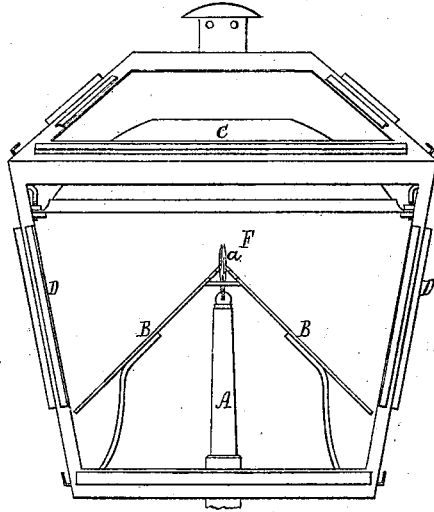

Fig. 2.

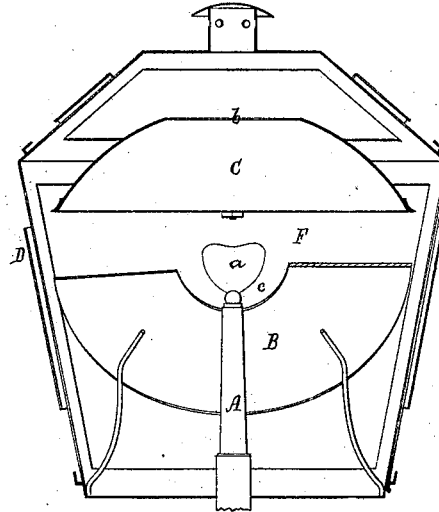

Fig. 3.

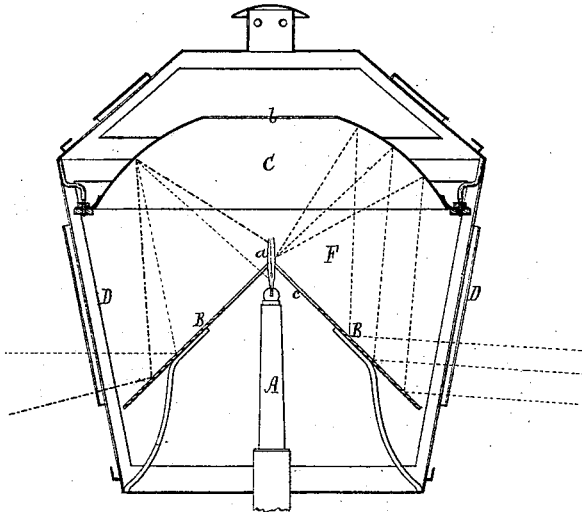
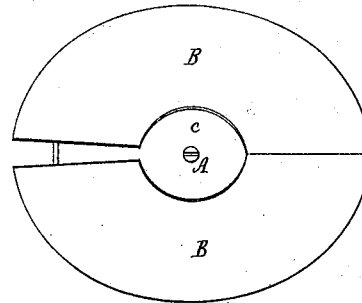

Fig. 4.



Witnesses.

L. N. Piper

John Brown

Inventor.

Edward S. Ritchie.

by his attorney

R. V. Lutz

UNITED STATES PATENT OFFICE.

EDWARD S. RITCHIE, OF BROOKLINE, MASSACHUSETTS.

IMPROVEMENT IN LANTERNS.

Specification forming part of Letters Patent No. 207,625, dated September 3, 1878; application filed July 24, 1878.

To all whom it may concern:

Be it known that I, EDWARD S. RITCHIE, of Brookline, of the county of Norfolk and State of Massachusetts, have invented a new and useful Improvement in Lanterns; and do hereby declare the same to be described in the following specification, and represented in the accompanying drawings, of which—

Figure 1 is a side elevation, and Figs. 2 and 3 are transverse and vertical sections, of a lantern containing my invention.

Although in this lantern I employ, in combination with a burner, a paraboloidal or bowl-shaped reflector and one or more auxiliary reflectors, I wish it to be understood that my present invention relates to an improvement on such, the principle on which such improvement is made being claimed or described by me in Letters Patent No. 170,451, dated November 30, 1876. Instead of arranging the bowl-shaped reflector between the burner and the auxiliary reflector or reflectors, and otherwise as shown in the said patent, I now, in carrying out my present improvement, arrange its larger end downward, above the burner, but generally entirely above the upper portion of the flame, so as not to intercept any of the direct rays issuing horizontally from the flame, the curvature of said reflector being such as to reflect the rays vertically downward instead of vertically upward upon the auxiliary reflectors. Furthermore, I have the auxiliary reflectors below or beneath the said bowl-shaped reflectors, and I prefer to range the plane of the latter reflectors with the middle, or about the middle, of the flame of the burner, when such burner is inflamed, such being in order to intercept as few as is practicable of the direct rays from the burner and not to cast a shadow near the lamp-post, and also to throw the rays reflected downward from the upper reflector in such directions and at such a distance where their light may be desired to reach.

When the lantern is placed at the side of a straight street each auxiliary reflector may be so inclined from a plane cutting the flame as to throw the rays more into the middle of the street on each side of the lantern.

In the drawings, A denotes the burner; *a*,

the flame thereof; B B, the auxiliary reflectors, and C the paraboloidal or bowl-shaped reflector. The reflecting-surface of the latter reflector is its concave surface, while the reflecting-surfaces of the other reflectors are their upward surfaces. The lantern-body D has a single chamber within it, for the reception of the burner and the above-described reflectors. The bowl-shaped reflector has an opening in its crown for the smoke to pass through.

As represented in the drawing, the two reflectors B B incline to each other at an angle of about eighty degrees, and the middle portion is cut away, as shown at *c*, about the diameter of the hole in the upper reflector, since there would be no rays to fall upon such portion removed, and also to intercept as few as possible passing direct from the upper portion of the flame to the space near the lantern-post, or from the lower part of the flame to a distance therefrom. Furthermore, each reflector B is a little oblique horizontally to the plane of the flame of the burner, such being as is shown in Fig. 4, which is a top view of such reflectors and burner.

I do not confine my invention to the precise form and arrangement of the reflectors B B, as represented, as such may be varied somewhat without changing the character of my improvement.

When this lantern is in use rays of light passing upward from the burner are intercepted by the bowl-shaped reflector, and by it are reflected downward, or about so, upon the surfaces of the plane reflectors B B in nearly parallel rays, and by them in turn are reflected, in two condensed beams, in such directions and to such distances as may be desirable to utilize them to best advantage.

Furthermore, the lantern-body has only one light-diffusive chamber, F, with glass or transparent sides. The fact that the rays issue from all portions of the flame, and not from a point, is an advantage, as they are thus slightly dispersed within a limit, or within the width of a street.

I am aware that it is not new to use such a concave reflector as I have shown, in combination with a conical reflector, their relations

to each other being the same, in which construction the rays are, by the conical reflector, dispersed in all directions.

In my arrangement the rays are condensed and thrown in two general directions, and thrown to a greater distance in powerful beams.

I claim as my invention as follows:

1. A bowl-shaped reflector arranged above the burner and having its larger end downward, in combination with the two auxiliary plane reflectors B B, arranged below or beneath said bowl-shaped reflector, substantially as specified.

2. The auxiliary reflectors B B, arranged so as to range with, or about with, the middle of the burner-flame and to incline downward from the burner, in combination with the bowl-shaped reflector arranged over such auxiliary reflectors B B, so as to reflect downward those rays from the flame, as specified.

EDWD. S. RITCHIE.

Witnesses:

R. H. EDDY,
JOHN R. SNOW.