

# E. BAINES. Reciprocating Engines.

No. 207,639.

Patented Sept. 3, 1878.

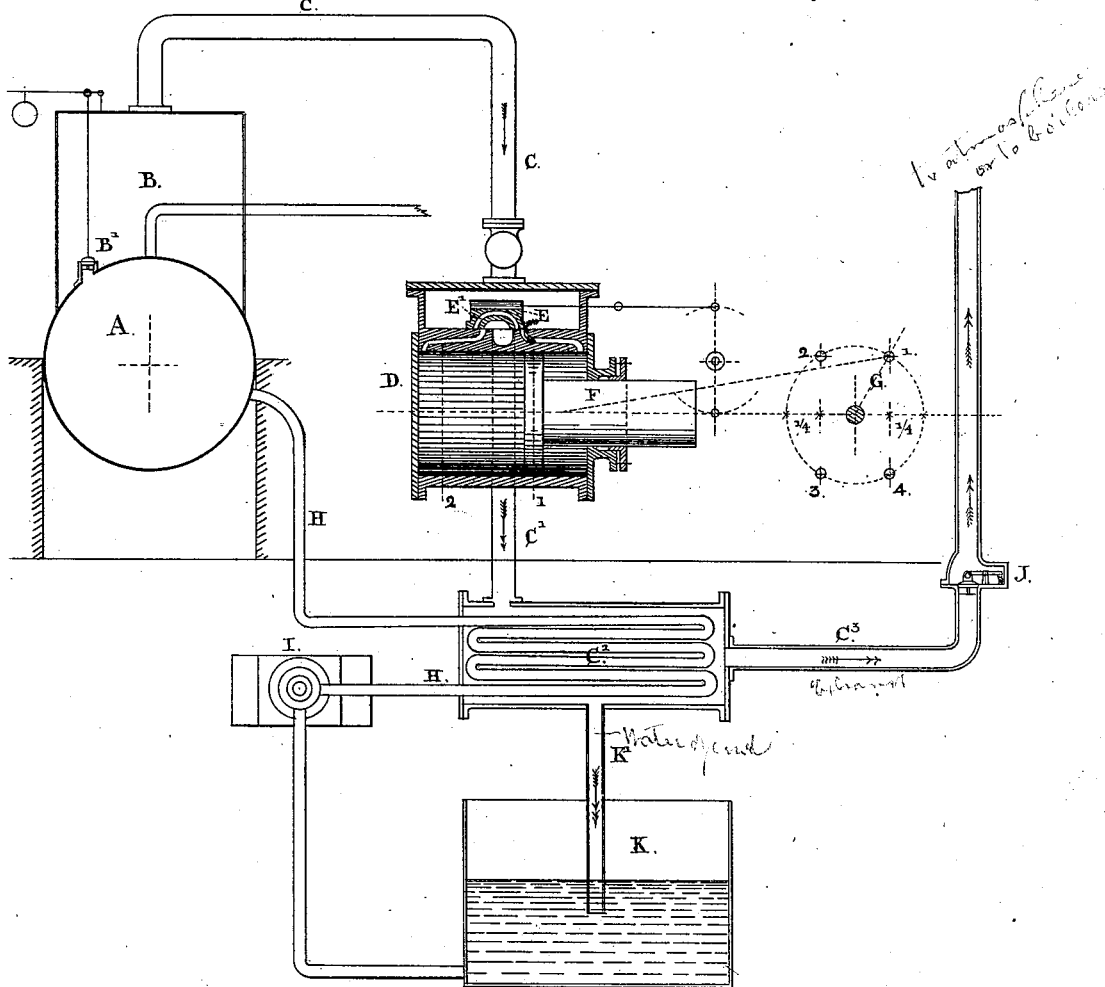

Fig. 1.

WITNESSES:

*L. Whitehead.*  
*A. Curran*

INVENTOR:

*Edward Baines*  
*by Ridout & Co*  
*Atty's*

E. BAINES.  
Reciprocating Engines.

No. 207,639.

Patented Sept. 3, 1878.

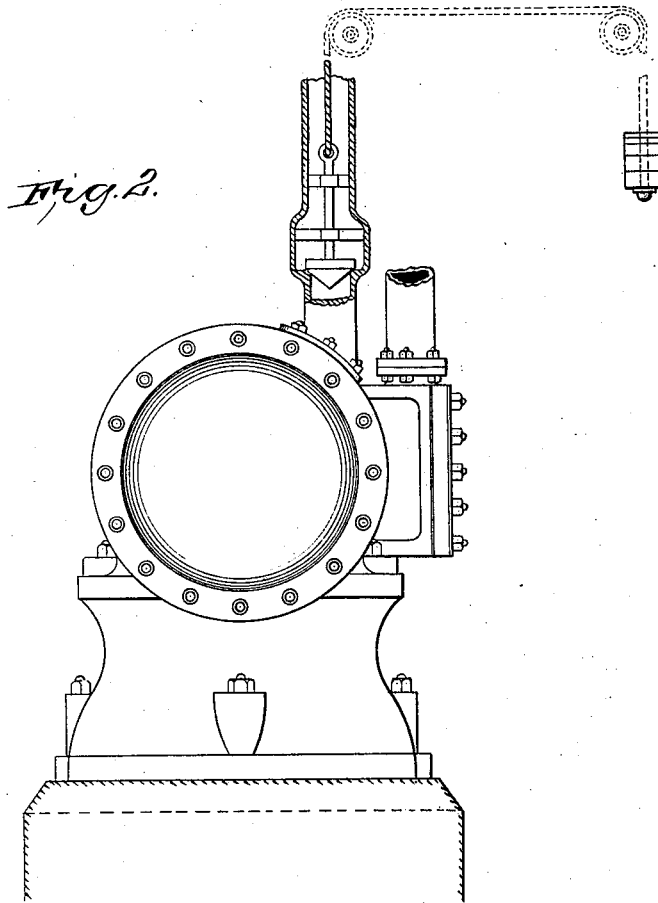

*Witnesses:*

*H. H. Warner*

*L. Whithead*

*Inventor:*

*Edward Baines*

*Ridout & Co*  
*Attys*

# UNITED STATES PATENT OFFICE.

EDWARD BAINES, OF TORONTO, ONTARIO, CANADA.

## IMPROVEMENT IN RECIPROCATING ENGINES.

Specification forming part of Letters Patent No. **207,639**, dated September 3, 1878; application filed June 7, 1877.

### *To all whom it may concern:*

Be it known that I, EDWARD BAINES, of the city of Toronto, in the county of York, in the Province of Ontario, Canada, mechanical engineer, have invented certain new and useful improvements in the method of obtaining motive power from steam, air, gases, liquids, and vapors, or other expansive matter, of which the following is a specification:

In the accompanying drawing, Figure 1 is a skeleton view of steam apparatus embodying my improvements.

A is the boiler, which is constructed and heated in any ordinary way. B is an expansion-chamber, connected to the boiler, into which steam is expanded from the boiler through the valve B<sup>1</sup>, which valve is weighted to a proper extent. C is the steam-induction pipe to the engine-cylinder D, and C<sup>1</sup> is the exhaust-pipe leading to the water heater and condenser C<sup>2</sup>, and thence out into the air or elsewhere. E is the slide-valve of engine; F, the piston, and G the crank. H is the feed-water pipe, passing through the heater or condenser from the pump I to the boiler.

Steam is raised in the boiler in the ordinary manner, and expanded into the chamber B through the valve B<sup>1</sup>, and from thence to the cylinder by the induction-pipe C. When the expansion-chamber is not used steam is admitted direct from the boiler to the cylinder.

The slide-valve E is of peculiar construction, being arranged and connected to admit steam to the cylinder at that point in the revolution of the crank, and the corresponding position of the piston indicated by the figures 1, and during that portion of the stroke in which the crank and piston travel from the figures 1 to 2. When the crank and piston reach the point indicated by the figure 2 steam is cut off, and remains cut off until the piston reaches the point 2 on the return stroke and the crank the corresponding point 3, when steam is admitted again, and until the piston travels to point 1 and the crank-pin to point 4, when steam is cut off. During the portions of the stroke of the piston in which the supply of live steam is cut off the steam in the cylinder is allowed by the movement of the slide-valve to fill the cylinder on each side of the piston, which piston will then travel to equilibrium by the move-

ment of the fly-wheel or its equivalent. On the return stroke, just before the live steam is admitted to one side of the piston, the steam on the other side is exhausted.

In order to accomplish the admission and exhaust of steam as above described, the valve E is provided with an equilibrium steam-passage, E', and is operated to admit and cut off the live steam at or about the point indicated.

The object in governing and using the steam in the manner above described is to economize steam by applying it at the most effective positions or angles of the crank.

In the operation of the engine, at the beginning of each stroke of the piston and until it reaches the point at which steam is admitted from the expansion-chamber or boiler the space between the piston and the cylinder-head and the ports are filled with steam exhausted from the other side of the piston and used in the previous stroke. This exhaust-steam exerts a certain pressure on the piston-head, and the admission of live steam brings up the pressure to the required working extent at a smaller cost than if the cylinder and port space had to be filled altogether with live steam from the boiler or expansion-chamber.

In the compound class of engines I admit a proportion of live steam to the exhaust-steam as it passes from the high-pressure cylinder to the low-pressure cylinder, in order to regenerate it and increase its elasticity and pressure.

The steam from the cylinder may be exhausted first into the condensing and heating chamber C<sup>2</sup>, a proportion, forced by its momentum, passing through the pipe C<sup>3</sup> and valve J into the air or elsewhere; or the majority of the exhaust-steam may be exhausted through the valve J into the boiler direct. The exhaust-pipe is provided with a valve, gate, or other suitable appliance, which is opened by the sudden rush of steam; but is closed by the back-pressure of the air, steam, or other opposing agent rushing into the exhaust-pipe, and assisted by a spring, if necessary. So soon as the force of the exhaust-steam is expended, the dead or inactive steam which does not pass into the air or boiler or elsewhere remains in the condensing-chamber and pipes connected thereto, and becomes condensed into vapor, then into hot water, and

passes into the hot-well K by the waste-pipe K', from which place it is drawn by the pump, and passed, together with a sufficient amount of cold water to make up the supply required by the boiler, through the pipes or chambers in the condenser and heater into the boiler.

The valve J also prevents the admission of cold air to the exhaust-pipe, heater, and cylinder, thus preventing them cooling. When the exhaust-steam leaves the cylinder it is throttled by the valve J, which allows the greater part of the latent heat of the steam along with a portion of the steam to escape. The remaining portion of the steam being deprived of its latent heat becomes more dense, and cannot escape through the valve J; consequently it is retained between the cylinder and exhaust-valve in the form of hot water and steam, from whence it escapes by means of the waste-pipe K' into the hot-well or other place designed to receive it. The valve J also prevents, and may be arranged to regulate, if desired, the admission of air or other matter into the cylinder or other part of the combination.

The exhaust end of the waste-pipe K' should be trapped or immersed in water, to prevent the admission of air or other exterior matter into the cylinder or other part of the apparatus. By this means the temperature of the cylinder or other part of the apparatus is kept at or near steam-heat, and little or no loss of steam is occasioned by the supply of live steam entering a partially-cold cylinder, as at present.

I obtain hot feed-water as follows: To the water condensed by the waste-pipe I add enough water to make a sufficient quantity for supplying the boiler. This water on its way to the boiler is passed through pipes or chambers placed in the heater or condenser, where it is still further heated.

I make no claim to the cushioning of engines or motors by exhaust-steam; but

I claim as my invention and desire to secure by Letters Patent—

1. The combination, with an engine-cylinder having a valve in the exhaust-passages thereof, of a condensing and heating chamber and a hot-well connecting with said chamber and with a feed-water pump, arranged substantially as specified.

2. The steam-cylinder D, provided with the valve E, the condensing and heating chamber C<sup>2</sup>, and the valve J, situated in the exhaust-passage of the cylinder, combined and arranged substantially as set forth.

3. The combination of the following elements, to wit: the steam-generator A, having the expansion-chamber B and variable pressure-valve B<sup>2</sup>, the steam-cylinder D, provided with the valve E, the condensing and heating chamber C<sup>2</sup>, and the valve J, situated in the exhaust-passage, all arranged substantially as set forth.

Toronto, January 28, 1878.

EDWARD BAINES.

In presence of—

A. M. ARMSTRONG,  
JOHN G. RIDOUT.