

G. T. GIFFORD.
Grain-Binder.

No. 207,655.

Patented Sept. 3, 1878.

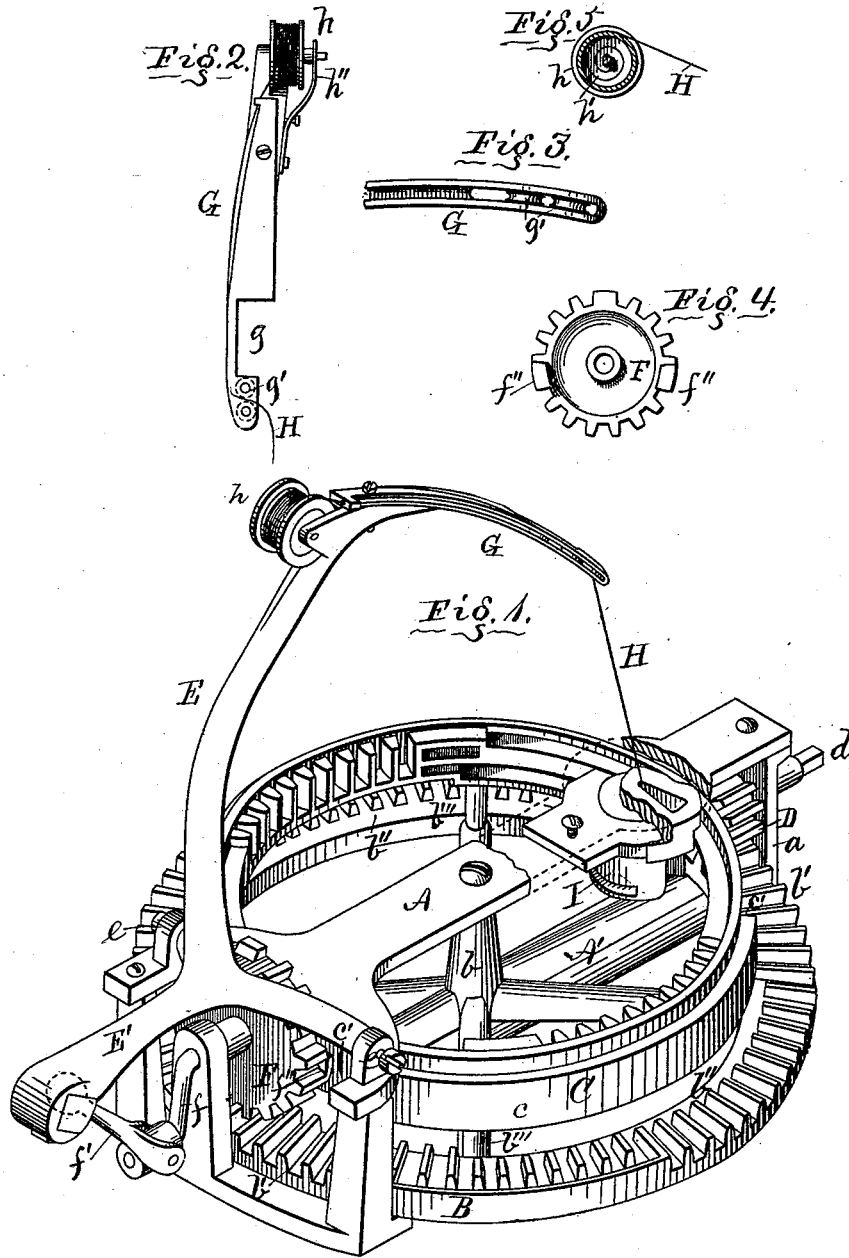

Witnesses:
M. H. Barringer,
A. McCallum

Inventor:
George T. Gifford,
By H. B. Richards
Atty

UNITED STATES PATENT OFFICE.

GEORGE T. GIFFORD, OF GALESBURG, ILLINOIS.

IMPROVEMENT IN GRAIN-BINDERS.

Specification forming part of Letters Patent No. 207,655, dated September 3, 1878; application filed January 4, 1878.

To all whom it may concern:

Be it known that I, GEORGE T. GIFFORD, of Galesburg, in the county of Knox and State of Illinois, have invented certain new and useful Improvements in Grain-Binders; and I do hereby declare that the following is a full, clear, and exact description thereof, which will enable others skilled in the art to which it appertains to make and use the same, reference being had to the accompanying drawings, and to letters of reference marked thereon, which form a part of this specification, in which—

Figure 1 is a perspective view of a grain-binder embodying my invention, and partly broken away to show the wire-twister. Fig. 2 is a front elevation of the needle. Fig. 3 is a side elevation of the needle enlarged. Fig. 4 is an elevation of the pinion which actuates the binder-arm. Fig. 5 is a sectional view of the spring-wire take-up. Fig. 6 is a perspective view of the interior side of the rim of the wheel C, showing said rim straightened out. Fig. 7 is a perspective view of the wire-twister frame, with the side to the front which goes next the wheel C. Fig. 8 is a vertical sectional view of Fig. 7. Fig. 9 is a perspective view of the upper pinion in the wire-twister. Fig. 10 is a perspective view of the middle pinion in the wire-twister. Fig. 11 is a perspective view of the lower pinion in the wire-twister. Fig. 12 is a side elevation of the wire-twister and a dotted diagram view of the wheel C. Fig. 13 is a perspective view of the wire-twister, showing where the needle passes through the pinions.

My invention relates to binder attachments to harvesting-machines; and consists in improvements in the method of actuating the binder-arm, in the construction of the needle or wire carrier, in improvements in the twister, and in combinations, all as hereinafter fully described, and set forth in the claims hereto annexed.

Referring to the parts by letters, each letter indicating the same part in the different views of the drawing, letters A A' represent, respectively, an upper and lower bar, constituting the frame on which the operating devices are seated. B is a crown-wheel, its shaft *b* journaled in the bars A A'. The upper face of the wheel B has two opposite and similar sets of full-length cogs,

b', and two opposite and similar sets of cogs with their inner ends removed, or half-length cogs, *b''*, dividing the wheel B into two equal and similar parts. Fixed to and above the wheel B by standards *b'''* is a smaller wheel, C, having internal gear, as shown more plainly at Fig. 6, which is a perspective view of the interior of said wheel unfolded or in a straight line.

The wheel C has delay-surfaces *c c* on its periphery, one on each side opposite each other, and with intervening spaces *c'*.

D is a pinion journaled in a bar, *a*, which connects the frame-bars A A'. The pinion D gears with all the cogs on the crown-wheel B, and may have a pulley or any other suitable gear on its shaft *d*, through which it may receive motion from any suitable shaft or wheel of a harvesting-machine.

E is the binder-arm, journaled at *e* to standards projecting from the frame A A', and having a rear projecting part, E', through which it receives motion from a pinion, F, by means of a crank, *f*, on said pinion, and a connecting-rod, *f'*, connected to the end of the arm E' by a ball-and-socket joint, and to the crank *f* by a swivel-joint, as shown at Fig. 1.

The pinion F is journaled in the frame A A', and is arranged so as to mesh with and be operated by the full cogs *b'* on the wheel B, and to run inside of and not mesh with the half-length cogs *b''*.

The number of each set of full-length cogs *b'* is such that they will rotate the pinion F once, and raise and lower the binder-arm E thereby, or raise and lower it twice to each revolution of the wheel B. The pinion F has projecting lugs *f''* on opposite sides, which lugs rest upon the delay-surfaces *c* on the wheel C, and act as stops to hold the pinion F while not in gear with the cogs *b''*, and thus hold the binder-arm while it is down and adjacent to the twister, as hereinafter described.

G is the wire-carrier or needle, its upper end attached to the end of the binder-arm E, and its lower end cut out at *g*, below which it is slotted laterally for the reception of pulleys *g'*, between which the wire H is passed. The wire H is carried on a reel, *h*, and its feed controlled by a spring take-up, *h'*, and tension *h''*.

I is the twisted case, shown fixed in position

in the frame A A' in Fig. 1, and in perspective, with its contained devices, at Fig. 7. The case I has a removed portion, J, for the passage of the needle G, and a removed portion, K, to allow the devices inside to gear with the interior gears on wheel C.

The wire holding, cutting, and twisting devices consist of three pinions, L, M, and N, mounted on a vertical shaft, O, within the case I, the upper pinion, L, being fixed to the shaft O, the middle pinion, M, seated thereon by a screw-threaded connection, and the lower pinion, N, loosely seated on the same shaft, as shown at Fig. 8. The upper pinion, L, has a disk, *l*, above it, to exclude dust, &c., from the twister, and said disk *l* has a slot, *l'*, in one side for the passage of the needle G. The pinion L has six leaves, as shown at Fig. 9, which shows said pinion with the disk *l* removed, four of which leaves are entire, and two of which, *l'' l'*, are only half thickness, as shown at same figure. The pinion M has six leaves, similar in size to the leaves on the pinion L, and one of them, *m*, has its upper half removed. (See Fig. 10.) The pinion N has also six leaves, with the upper and lower halves, respectively, of the alternate leaves removed. (See Fig. 11.)

To illustrate the operation of the twister, I have shown in dotted lines a diagram view of the gear and delay-surfaces of the wheel C as they come in contact at Fig. 12.

At Fig. 12 the delay-surface 1 of the wheel C rests against the flat surfaces of pinions L and M left by the removal of half of the cogs *l''* and *m*, and acts as a detent to stop and hold said pinions, and the cam-surface 2 is resting against the flat surface left by the removal of half of one of the cogs of the pinion N for the same purpose. While the wheel C is in the relative position to the twister shown at Fig. 13, the needle G is down, as shown at same figure, and the space *g* removed from its lower end will permit the twister-pinions L, M, and N to rotate. The wheel C moving in the direction of the arrow at Fig. 12, the cog 3 will strike the leaf *l''* of the pinion L and carry it forward one-sixth of a revolution, thereby gripping and holding the wire (which is between the cogs where the needle passed down) between two of the teeth of pinions L and M by means of an approaching cog of the pinion L pressing the wire over and between it and a cog of the pinion M, as shown at Fig. 13. Rotating the pinion will also rotate the shaft O, and its screw-threaded portion will be drawn forward into the pinion M, and thus draw pinions L and M toward each other and increase their gripe on the wire. The cog 4 then strikes the adjacent leaf of the pinion N and rotates it one-sixth of a revolution, thereby seizing the wire between a leaf of the pinion N and the bottom of the case I, and also catching it between two of the leaves of pinions M and N, which cut it in two. (See Fig. 13.) The lower pinion, N, is then held from rotating by the detent cam-surface 5, rest-

ing against the flat surface of the removed half-cog, and the cogs 6 gear with and rotate the upper disks, L and M, with the ends of the wire secured between them, as hereinbefore stated, and thus twist them and secure them together. The pinion L is stopped by the end of the cam-surface 1 a short time before the pinion M, which is then rotated one-sixth of a revolution by the cog 7, which releases the wire from between the pinions L and M, and brings them again to the same relative positions from which they started. The wire being still held between the pinion N and bottom of case I, and the pinions L, M, and N held from movement by the cam-surfaces on the wheel C, the needle is raised, as hereinbefore described, and the bundle of grain, being pressed against the wire by any ordinary devices for the purpose between the case I and the needle, will press the wire back, so that the descent of the needle will encircle the grain-bundle with the wire and the needle descend through the case I and the twister, where the same operation of seizing the wire, cutting it off, and twisting it, as hereinbefore described, will be repeated. Each revolution of the wheel C will tie two bundles of grain.

It will be observed that while the needle is being raised and lowered, the twister is motionless, and vice versa.

The device may be seated in any suitable position or manner on a grain-harvester, with appliances for delivering the grain in bundles, and the wheels B and C should be covered with a suitable platform, to shield them and to receive the bundles of grain.

What I claim as new, and desire to secure by Letters Patent, is—

1. The crown-wheel B, having series of half-cogs and full cogs, in combination with the pinion F, crank *f*, connecting-rod *f'*, and binder-arm E, substantially as and for the purpose specified.

2. The crown-wheel B, having series of half-cogs and full cogs, in combination with the pinion F, having lugs *f''*, and the wheel C, having cam-surfaces *c*, substantially as described, and for the purpose specified.

3. The wheels B C, in combination with pinion F, binder-arm E, and a wire-twister device, substantially as and for the purpose specified.

4. The wheel C, having exterior detent cam-surfaces for stopping and holding the pinion F, and internal gear for actuating the twister, combined to operate with the binder-arm of a grain-binder, substantially as and for the purpose specified.

5. The wheel C, having internal gear for actuating the twister, in combination with the wheel B, connected to the wheel C, and having gear for actuating the binder-arm, substantially as and for the purpose specified.

6. The pinion M, seated by a screw-connection on the shaft O, and combined with the pinion L, so as to approach and recede therefrom, substantially as and for the purpose specified.

7. The wheel C, having internal gear, constructed as described, in combination with pinions L M N, having whole and half leaves, substantially as described, and for the purpose specified.

8. The wheels B and C, pinion F, and binder-arm E, in combination with the wire-twister, formed of a series of pinions, substantially as described, and for the purpose specified.

9. The needle-arm G, having a space, *g*, in combination with wire-twister pinions, through which the needle passes, the space *g* permitting

the pinions to rotate, substantially as described, and for the purpose specified.

10. The pinion D, in combination with the wheels B and C and binder-arm, substantially as and for the purpose specified.

In testimony that I claim the foregoing as my own I affix my signature in presence of two witnesses.

GEORGE T. GIFFORD.

Witnesses:

THOMAS MCKEE,
M. H. BARRINGER.