

L. B. HOWLAND.
Picking Motion for Looms.

No. 207,660.

Patented Sept. 3, 1878.

Fig. 1.

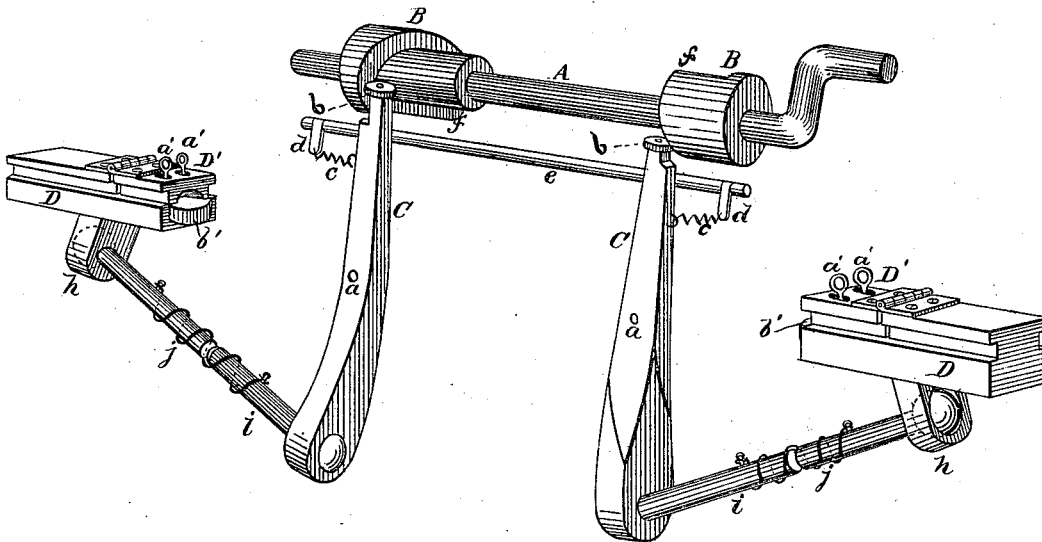

Fig. 2.

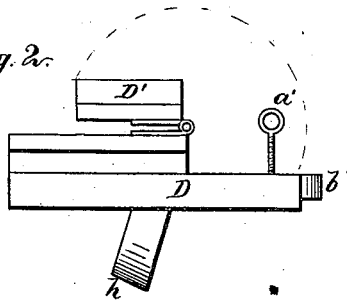
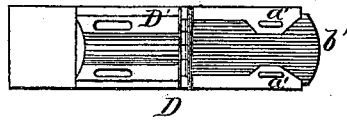

Fig. 3.



WITNESSES:

Henry N. Miller
C. Sedgwick

INVENTOR:

L. B. Howland
BY

ATTORNEYS.

L. B. HOWLAND.
Picking Motion for Looms.

No. 207,660.

Patented Sept. 3, 1878.

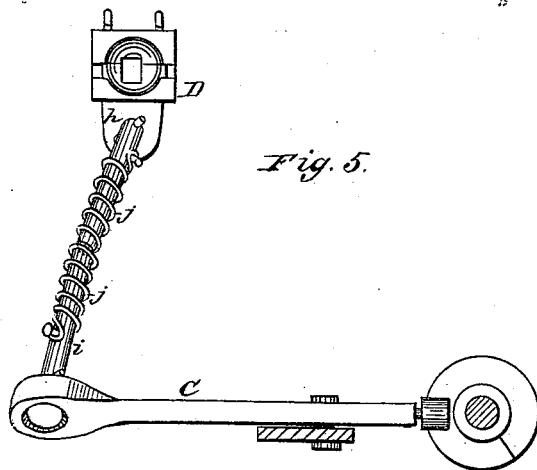
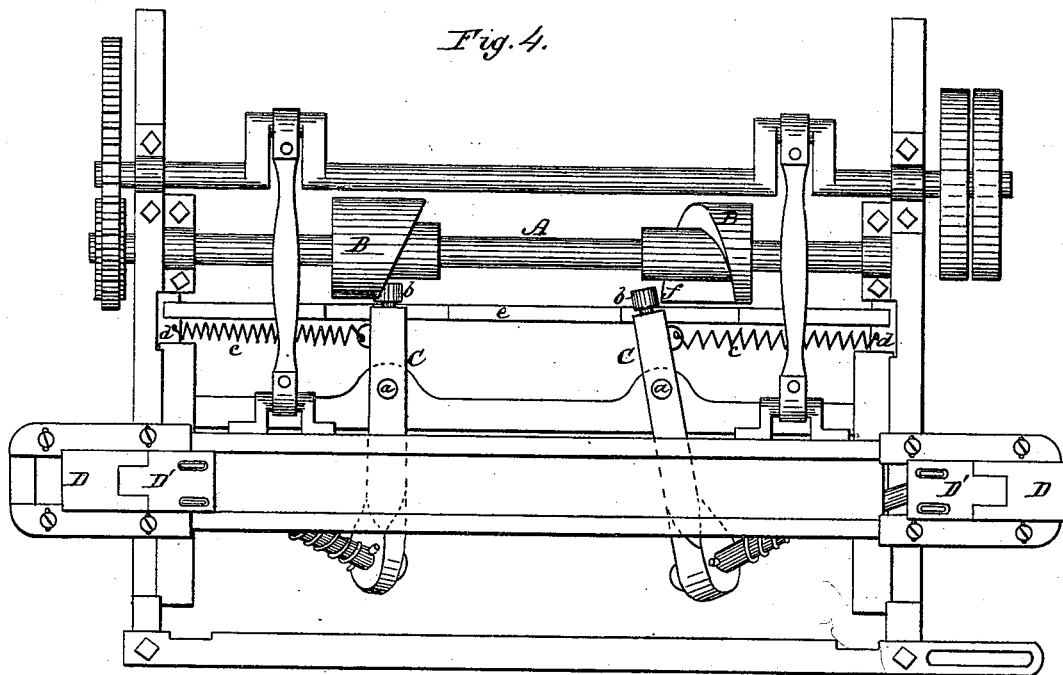

WITNESSES:

John Kemou
R. M. Hollingsworth

INVENTOR:

L. B. Howland

BY

Munn & Co.

ATTORNEYS.

UNITED STATES PATENT OFFICE.

LYMAN B. HOWLAND, OF LAKEVILLE, MASSACHUSETTS.

IMPROVEMENT IN PICKING-MOTIONS FOR LOOMS.

Specification forming part of Letters Patent No. **207,660**, dated September 3, 1878; application filed May 6, 1878.

To all whom it may concern:

Be it known that I, LYMAN B. HOWLAND, of Lakeville, in the county of Plymouth and State of Massachusetts, have invented a new and useful Improvement in Picking-Motions for Looms, of which the following is a specification:

Figure 1 is a perspective view of a portion of a loom embodying my improvement. Figs. 2 and 3 are detail views, showing the shuttle-driving blocks. Fig. 4 is a top view of a portion of a loom embodying my invention; Fig. 5, a detail view of some of the parts.

Similar letters of reference indicate corresponding parts.

My invention relates to the shuttle-driving mechanism of looms; and it consists in a peculiar arrangement of cams, levers, springs, and yielding connecting-rods, whereby the shuttle is driven at a uniform speed irrespective of the speed of the loom.

Referring to the drawing, A is the cam-shaft, carrying two similar but oppositely-disposed cams, B B; and C C are levers, fulcrumed at *a*, and having at their upper ends rollers *b*, which engage the cams B B. These levers are thrown into engagement with the cams by the springs *c*, which are connected with the outer sides of the levers, and with arms *d* that project from a rod, *e*, that is supported by the frame of the loom.

The cams B are spiral, and the spiral surface terminates in a straight ledge, *f*, that runs parallel with the shaft, so that as the rollers on the ends of the levers C escape the end of the spiral the upper end of the lever is thrown outward, and the lower end is correspondingly drawn inward.

D D are blocks, having grooves in their sides to receive the tongues or ways in the shuttle-boxes, by which they are guided. These blocks are provided with a hinged portion, D', which is slotted to receive the upper ends of two screw-eyes, *a'*, which enter the lower portion of the block, and when turned act as fasteners to the hinged part. The lower part

of each block is chambered out to receive a buffer, *b'*, of semi-elastic material, such as leather, cloth, felt, or rubber, to arrest the motion of the shuttle at the end of each pick. The chamber in the blocks is contracted near the mouth, to afford a means of holding the buffer in the block. The buffer *b'* may at any time be removed by releasing and throwing back the hinged portion D'. The blocks D are provided with ears *h*, that extend below the shuttle-box, to receive the upper end of the connecting-rod *i*, which is spherical, and forms, with the spherical cavity in the ear *h*, a ball-and-socket joint. The connecting-rods *i* are connected by means of a similar joint with the lower end of the levers C. They are also divided in the center, and the two parts of each are connected by means of a spiral spring, *j*, which extends some distance beyond the adjoining ends of the two parts of the rod, and is fastened by one end to each part of the rod.

By means of this device the connecting-rods give the shuttle an easy motion at every pick.

It will be observed that the springs *c* are depended on to throw the shuttle, and as their force is always a constant quantity the shuttle will always move with the same velocity, and in consequence of this arrangement the action of the shuttle will always be uniform.

Having thus described my invention, I claim as new and desire to secure by Letters Patent—

1. The combination of the divided connecting-rods, having the connecting-spring *j*, with the shuttle-driving blocks D and mechanism for operating the same, substantially as herein shown and described.

2. The combination of the cams B, levers C, yielding connecting-rods *i*, the rod *e*, provided with arms *d*, and the actuating-springs *c*, for driving the shuttle, as herein shown and described.

LYMAN B. HOWLAND.

Witnesses:

H. C. BURBY,
JONATHAN CHAFFEE.