

W. MILLER.
Shaking-Grate for Stoves.

No. 207,670.

Patented Sept. 3, 1878.

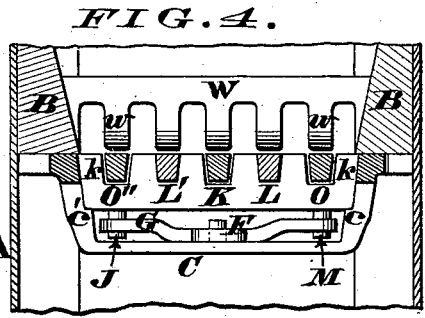
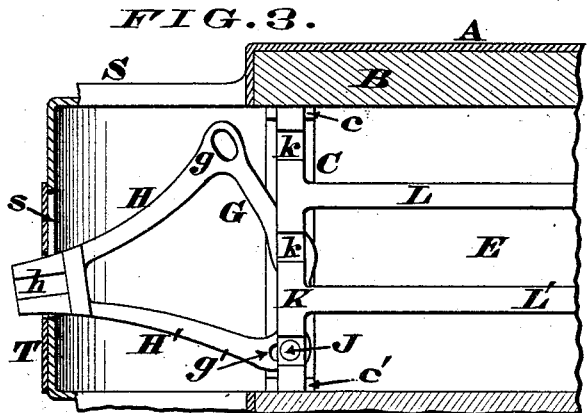
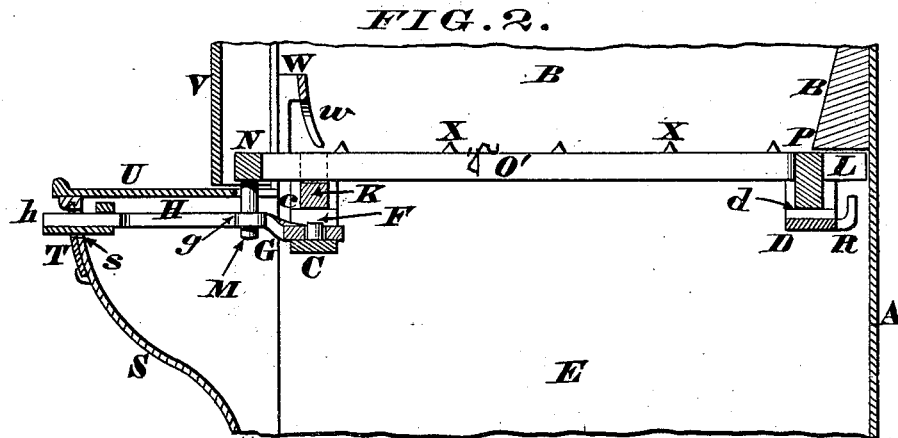
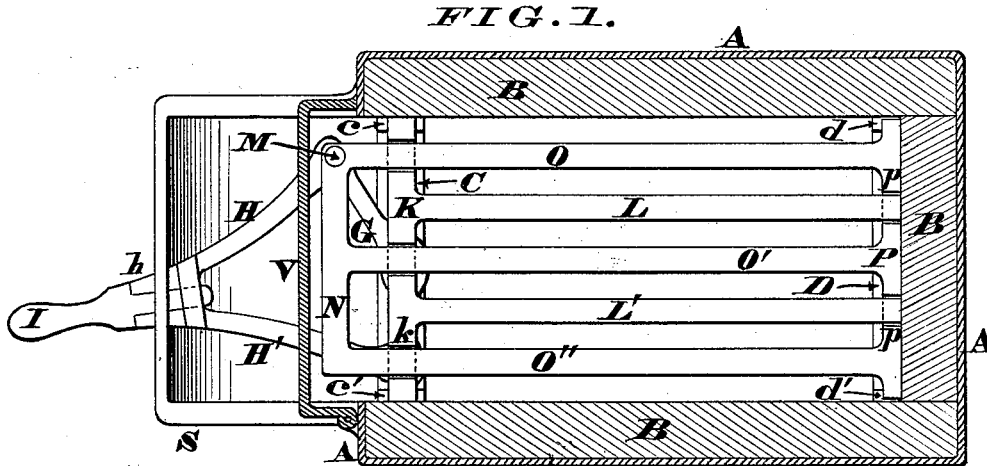

Attest.
George H. Colker
S. Bond

Inventor.
William Miller
By James H. Loayman
His Attorney

UNITED STATES PATENT OFFICE.

WILLIAM MILLER, OF CINCINNATI, OHIO.

IMPROVEMENT IN SHAKING-GRATES FOR STOVES.

Specification forming part of Letters Patent No. 207,670, dated September 3, 1878; application filed July 29, 1878.

To all whom it may concern:

Be it known that I, WILLIAM MILLER, of Cincinnati, Hamilton county, Ohio, have invented certain new and useful Improvements in Shaking-Grates for Stoves, Ranges, &c., of which the following is a specification:

This invention relates to those shaking-grates which consist of two reciprocating sections having interposed bars adapted to move in opposite directions; and the first part of my improvements comprises a novel combination of pivoted rocker, slots, and pins for producing the reciprocations of such sections, as hereinafter more fully described, and pointed out in the claims.

The second part of my invention consists in combining with the aforesaid rocker and grates a pair of transverse bearing-bars that guide the reciprocating sections in a proper path within the fire-chamber, as hereinafter more fully described, and pointed out in the claims.

The third part of my invention consists in providing the front of the fire-chamber with a series of fixed and rearwardly-curved fingers, situated in line with the grate-bars, and adapted to clear them of clinkers, &c., when motion is imparted to the reciprocating sections, as hereinafter more fully described, and pointed out in the claims.

In the annexed drawing, Figure 1 is a horizontal section of a fire-chamber provided with my improved form of shaking-grate, the section being taken immediately above the grate-bars. Fig. 2 is a vertical section of the same, taken in the plane of the rocker-pivot. Fig. 3 is another horizontal section, showing a portion of the fire-chamber, the upper member of the grate being removed therefrom; and Fig. 4 is a transverse section of the grate.

A represents the outer shell or casing of a stove or range or other cooking or heating apparatus, and B B B are the customary fire-chamber linings, which linings are preferably supported on two bars, C D, disposed transversely of and above the ash-pit E, as seen in Fig. 2. These bars are provided, respectively, with bearings *c c'* and *d d'*, for a purpose that will presently appear. Of these bars the front one, C, has an upwardly-projecting pin or pivot, F, to which is applied a rocker, G, adapted to vibrate in a horizontal plane. Furthermore,

said rocker is pierced with two eyes or slots, *g g'*, and has a pair of converging arms, H H', at whose junction is situated a socket, *h*, to receive the detachable handle I. Inserted in the eye or slot *g'* is a depending lug or pin, J, of a bar, K, which bar is adapted to reciprocate on the bearings *c c'*, and has cast with it two or more rearwardly-projecting grate-bars, L L', of any approved shape. Bar K is grooved transversely at *k* to permit free play of the grate-bars of the other section.

Inserted in the other eye or slot, *g*, of the rocker is a pin or stump, M, of a bar, N, with which bar are cast three or more grate-bars, O O' O'', whose rear ends are united by a bar, P, that rides on the bearings *d d'*. Bar P is grooved transversely at *p*, to permit free play of the rear portions of bars L L', whose extreme rear ends may be united, if desired; but such a precaution is not considered necessary.

R are stops on the rear bar D, for the purpose of limiting the stroke of bar P. Socket *h* is adapted to have lateral play in the horizontal slot *s* of the extension S, said slot being covered with a sliding guard-plate, T, to prevent escape of dust and ashes from pit E when the grate is shaken. U is the hearth-plate, and V the fire-door of the oven, range, or stove. Disposed transversely of the fire-chamber is a bar, W, having a series of depending and rearwardly-curved fingers, *w*, located directly above and in line with the various grate-bars L L' O O' O'', as more clearly seen in Fig. 4. The upper surfaces of these grate-bars may be furnished with transverse ribs or projections X, as seen in Fig. 2.

To operate my grate, it is only necessary to insert a handle or poker in the socket *h*, and then impart a lateral vibration to said handle, which act causes a corresponding oscillation of rocker G on pivot F. The bars L O are thereby reciprocated, but in opposite directions—that is to say, while the ones L are advancing the other ones, O, are receding, and vice versa—and as a result of this opposite reciprocation of said interposed bars the fuel in the fire-chamber is agitated in the most thorough and uniform manner.

By referring to Fig. 4, it will be noticed that the lower ends of fingers *w* are in close proximity with the grate-bars L O, and conse-

quently when the two sections advance, these fingers strip said bars of clinkers, &c., that might otherwise adhere thereto and prevent the proper action of the apparatus.

I am aware it is not new to provide a shaking-grate with two reciprocating sections having interposed bars, and therefore my claim to this part of the apparatus is expressly limited to the combination of pivoted rocker, slots, and pins for operating such reciprocating sections.

I claim as my invention—

1. The combination of pivoted rocker F G *g g'*, pins J M, and oppositely-reciprocating grate-sections K *k* L L' N O O' O'' P *p*, substantially as herein described.

2. An improved shaking-grate consisting of

bearing-bars C *c c'* D *d d'*, pivoted rocker F G *g g'* H H' *h*, and oppositely-reciprocating sections J K *k* L L' M N O O' O'' P *p*, substantially as herein described.

3. In combination with the oppositely-reciprocating grate-sections K *k* L L' N O O' O'' P *p*, the rearwardly-curved and fixed fingers *w*, situated in line with the bars L L' O O' O'', substantially as herein described.

In testimony of which invention I hereunto set my hand.

WILLIAM MILLER.

Witnesses:

JAMES H. LAYMAN,
CHARLES TRUESDALE.